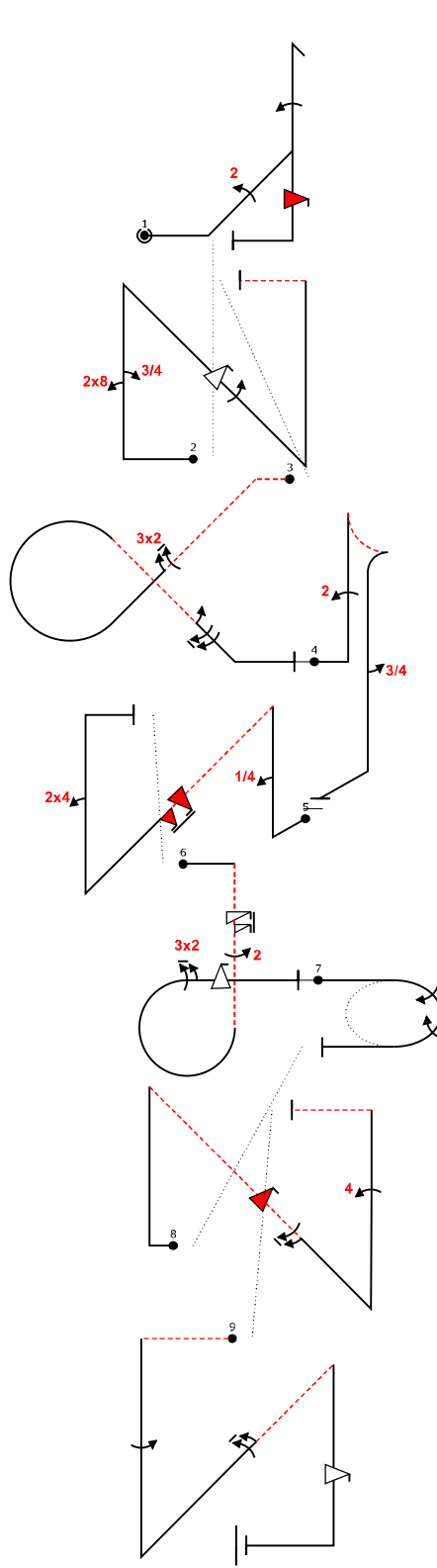

Fig 1	5.2.1.1	17	57
	9.4.1.5	18	
	9.10.5.4	13	
	9.1.5.5	9	
Fig 2	1.3.14.1	22	66
	9.1.1.1	6	
	9.1.1.3	10	
	9.4.1.2	9	
	9.9.4.4	11	
Fig 3	1.3.11.4	20	54
	9.2.2.4	11	
	9.1.2.2	6	
	9.2.5.4	9	
Fig 4	6.2.1.1	15	30
	9.2.1.4	13	
	9.1.5.1	2	
Fig 5	1.3.13.1	22	52
	9.8.1.1	7	
	9.1.4.8	12	
	9.8.1.2	11	
Fig 6	7.8.15.3	23	47
	9.1.4.6	10	
	9.2.4.4	9	
	9.4.4.2	5	
Fig 7	1.3.12.1	21	45
	9.10.4.6	16	
	9.1.1.2	8	
Fig 8	8.6.4.3	13	39
	9.11.1.6	3	
	9.2.3.6	12	
	9.9.3.4	11	
Fig 9	2.3.4.1	30	30
Total K = 420			

PAUL ANDRONICOU
 MX-2
 pilot
 A/C



WAC 2013		Form B
Pilot ID	Unlimited Programme Free	Flight #



← wind/vent

Power			
Fig 1	5.3.1.1.1	18	54
	9.2.2.4	11	
	9.1.1.4 9.10.5.4	12 13	
Fig 2	1.3.1.4.1	22	58
	9.8.1.1	7	
	9.1.1.3	10	
	9.9.4.4 9.1.4.4	11 8	
Fig 3	7.3.4.4	15	43
	9.2.4.6	12	
	9.1.4.2	4	
	9.1.4.8	1.2	
Fig 4	6.2.2.1	15	34
	9.2.1.4	1.3	
	9.1.5.3	6	
Fig 5	1.3.1.2.1	21	52
	9.1.1.1	6	
	9.10.4.6	16	
	9.4.1.2	9	
Fig 6	8.6.4.3	13	48
	9.11.1.6	3	
	9.2.5.4	9	
	9.2.3.6 9.9.3.4	12 11	
Fig 7	2.2.5.1	22	22
Fig 8	1.3.1.1.1	20	58
	9.10.4.4	13	
	9.1.4.6	10	
	9.4.1.4	15	
Fig 9	1.3.1.1.4	20	51
	9.1.5.4	8	
	9.1.2.6	12	
	9.9.5.4	11	
Total K = 420			

Rob Noonan Pilot
MX2 N487MX A/C

Pilot ID #

Unlimited Free

Flight #

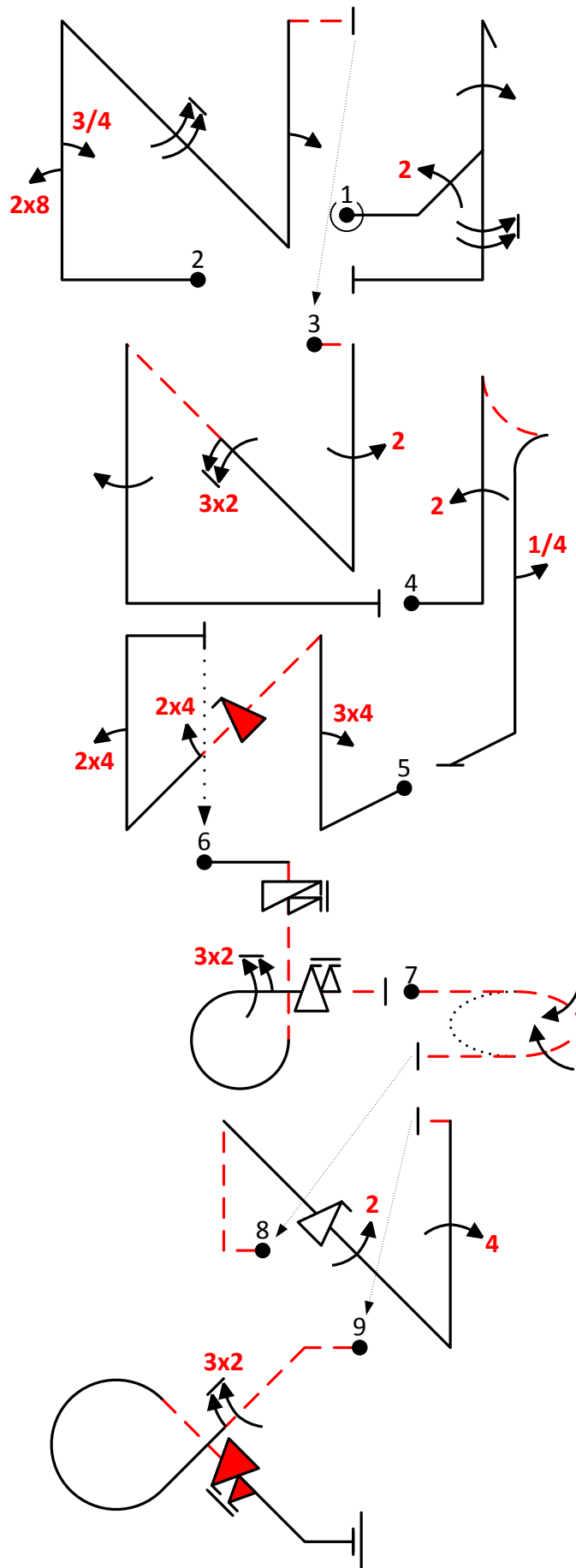
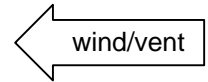

Fig 1	5.3.1.1	18	53
	9.2.2.4	11	
	9.1.1.4	12	
	9.1.5.8	12	
Fig 2	1.3.14.1	22	59
	9.8.1.1	7	
	9.1.1.3	10	
	9.1.4.8	12	
	9.1.1.2	8	
Fig 3	1.3.11.4	20	51
	9.2.5.4	9	
	9.2.2.6	14	
	9.1.5.4	8	
Fig 4	6.2.2.1	15	30
	9.2.1.4	13	
	9.1.5.1	2	
Fig 5	1.3.12.1	21	60
	9.4.1.3	12	
	9.10.4.4	13	
	9.4.4.2	5	
	9.4.1.2	9	
Fig 6	8.6.3.3	13	42
	9.11.1.6	3	
	9.2.3.6	12	
	9.9.3.6	14	
Fig 7	2.2.5.2	23	23
Fig 8	1.3.9.2	24	59
	9.9.4.4	11	
	9.2.4.4	9	
	9.4.1.4	15	
Fig 9	7.3.4.4	15	43
	9.2.4.6	12	
	9.10.4.6	16	
Total K = 420			

Pilot ID #

Unlimited Free

Flight #

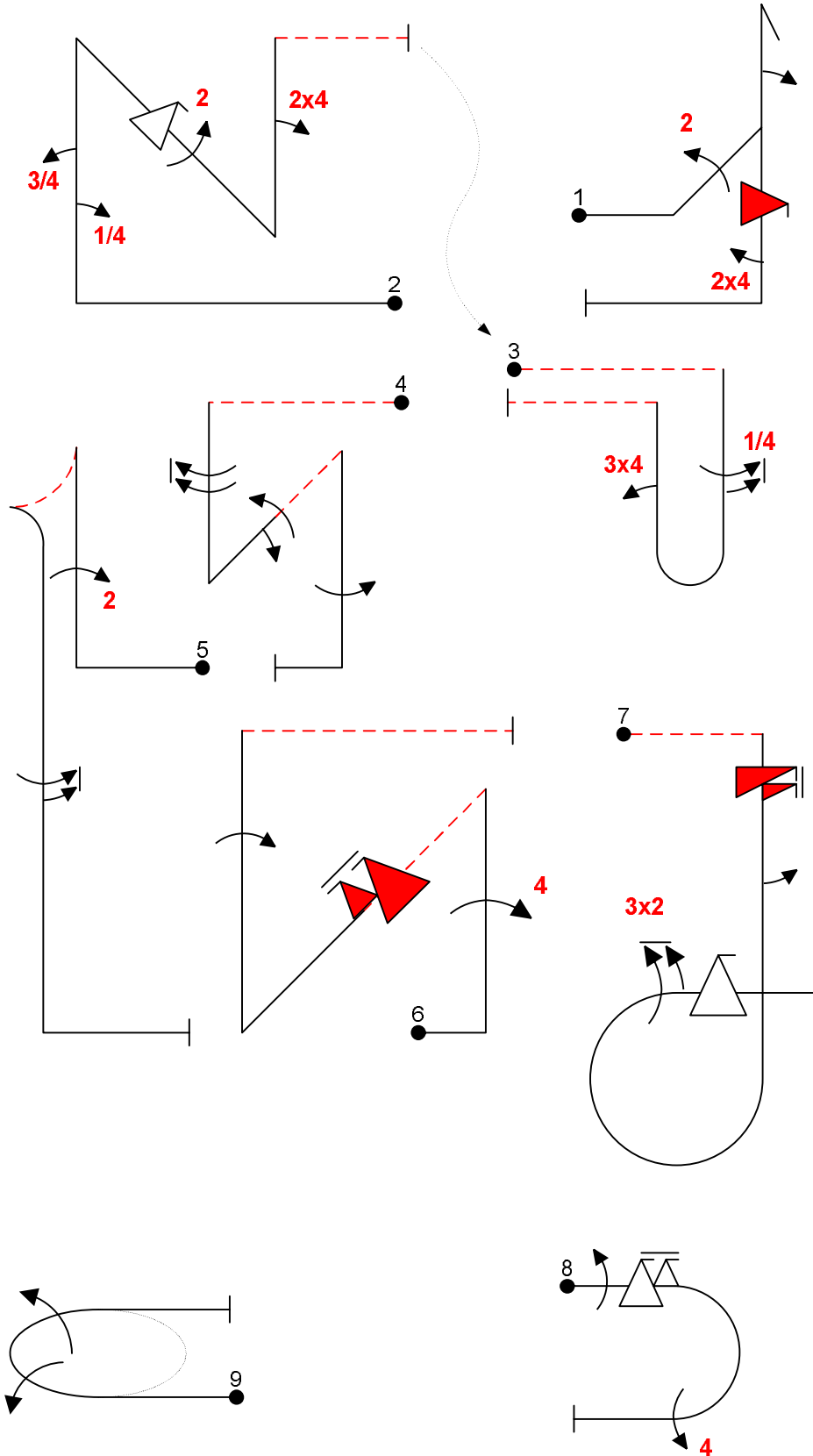
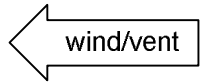
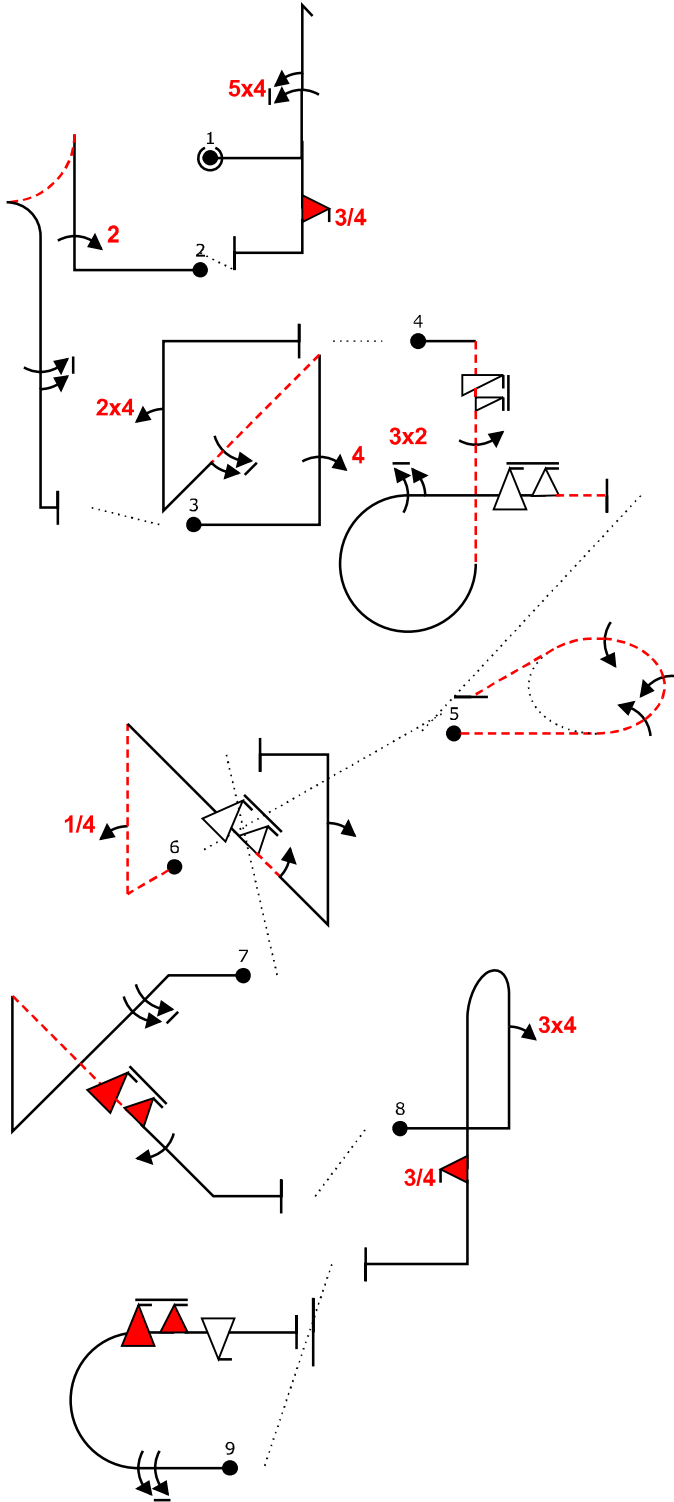
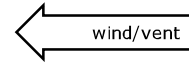

Fig 1	5.3.1.1 9.2.2.4 9.10.5.4 9.4.5.2 9.1.1.2	18 11 13 5 8	55
Fig 2	1.3.14.1 9.1.1.1 9.1.1.3 9.9.4.4 9.2.4.4 9.4.1.2	22 6 10 11 9 9	67
Fig 3	8.4.1.4 9.1.5.5 9.4.1.3	13 9 12	34
Fig 4	1.3.11.4 9.1.5.8 9.1.2.2 9.1.2.4 9.1.5.4	20 12 6 10 8	56
Fig 5	6.2.2.1 9.2.1.4 9.1.5.6	15 13 10	38
Fig 6	1.3.11.1 9.4.1.4 9.10.4.6 9.1.1.4	20 15 16 12	63
Fig 7	8.6.2.4 9.9.3.4 9.2.3.6 9.12.1.6 9.1.5.2	12 11 12 5 4	44
Fig 8	7.2.3.3 9.1.3.4 9.9.3.6 9.4.3.4	6 8 14 11	39
Fig 9	2.2.5.3	24	24

Total K = 420



		Form B
Pilot ID	unlimited Programme free	Flight #



Power			
Fig 1	5.2.1.1	17	48
	9.4.1.5	18	
	9.10.5.3	13	
Fig 2	6.2.2.1	15	38
	9.2.1.4	13	
	9.1.5.6	10	
Fig 3	1.3.12.1	21	55
	9.4.1.4	15	
	9.1.4.6	10	
	9.4.1.2	9	
Fig 4	8.6.3.3	13	50
	9.11.1.6	3	
	9.1.5.4	8	
	9.2.3.6	12	
Fig 5	2.3.4.2	31	31
Fig 6	1.3.10.2	24	56
	9.1.1.1	6	
	9.9.4.6	14	
	9.1.4.2	4	
Fig 7	1.3.3.3	18	54
	9.1.4.8	12	
	9.10.4.6	16	
	9.1.4.4	8	
Fig 8	8.4.1.1	13	40
	9.4.1.3	12	
	9.10.10.3	15	
Fig 9	7.2.2.1	6	48
	9.1.3.8	12	
	9.10.8.6	19	
	9.9.3.4	11	
Total K = 420			

Didier A melinckx Pilot
Ex 330SC F-HSDA A/C

Pilot ID #

Unlimited Free

Flight #

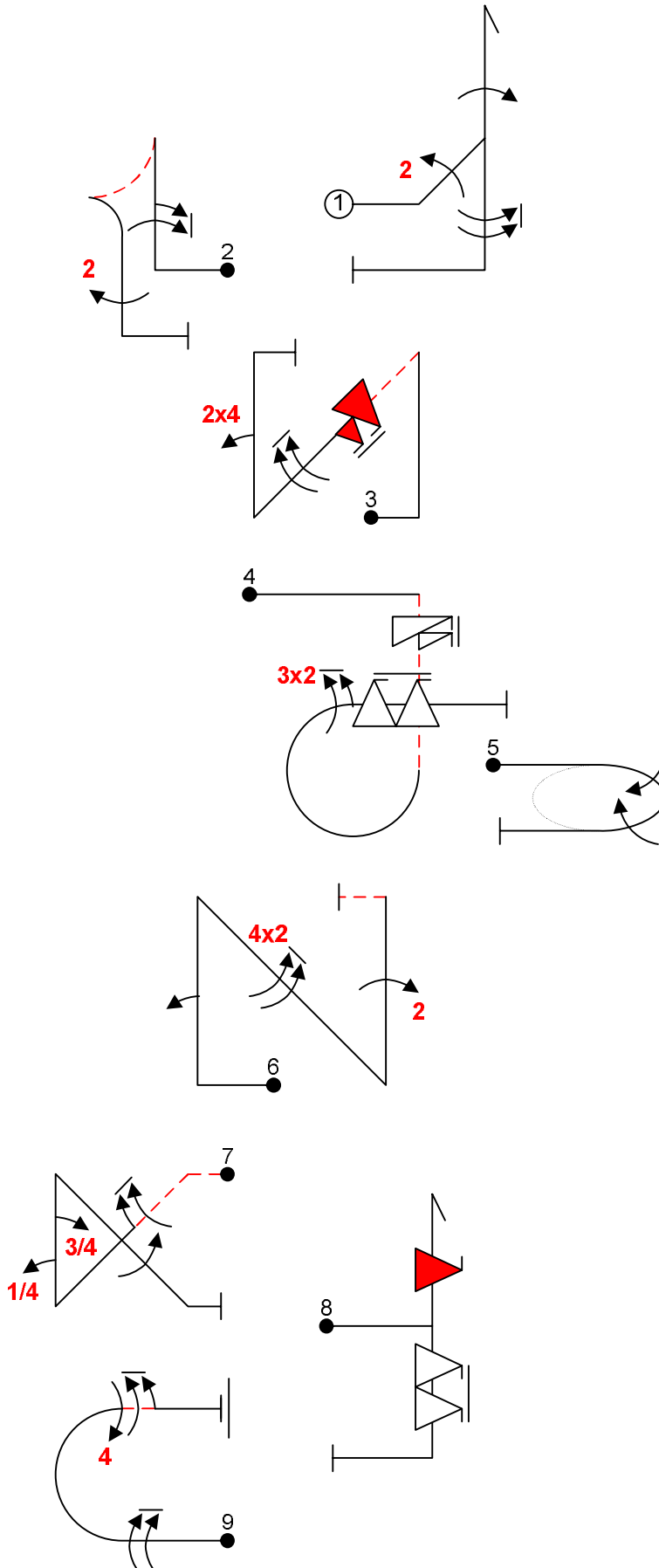
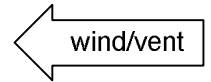
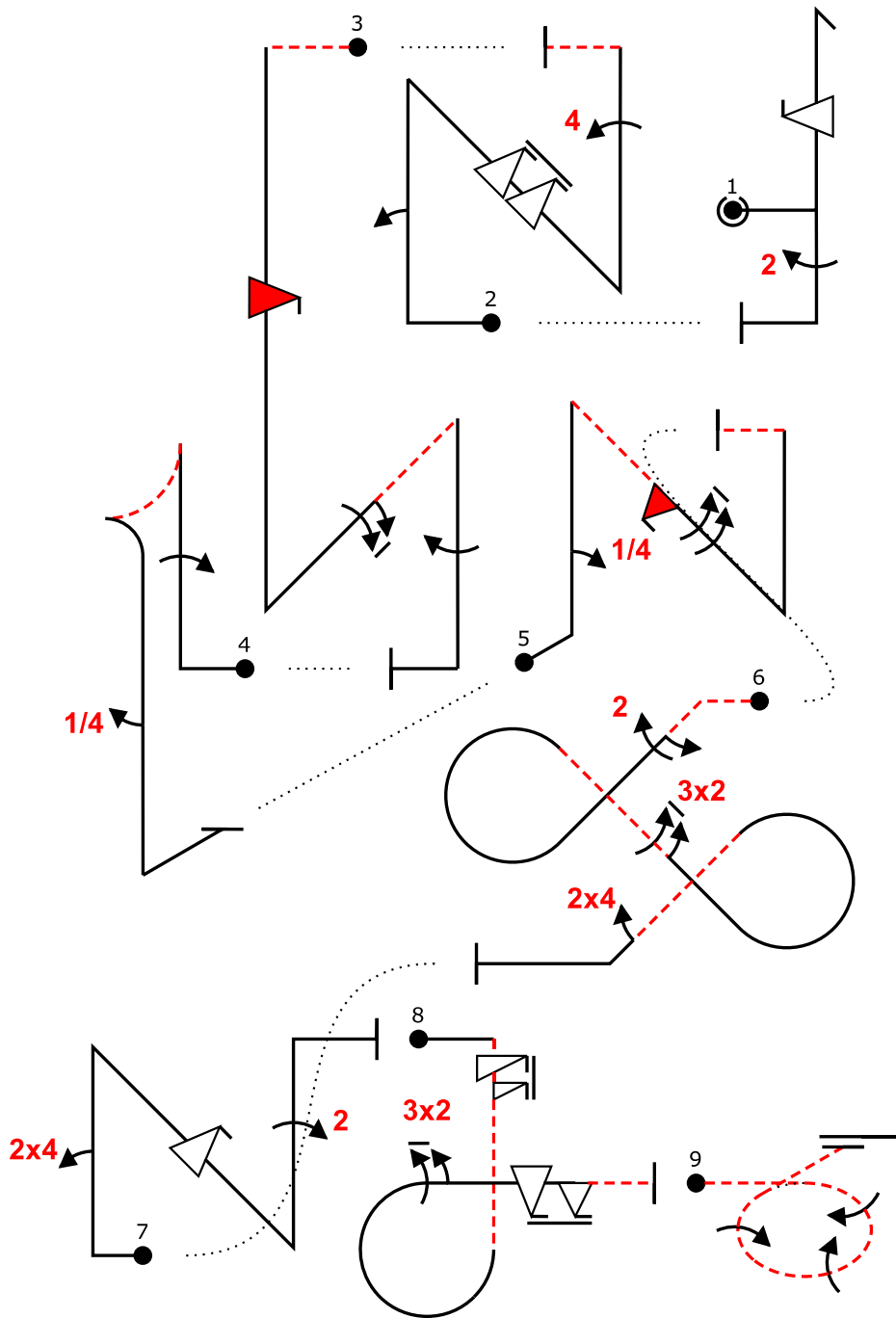
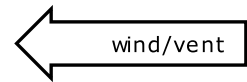

Fig 1	5.3.1.1 9.2.2.4 9.1.1.4 9.1.5.8	18 11 12 12	53
Fig 2	6.2.2.1 9.1.1.6 9.2.5.4	15 15 9	39
Fig 3	1.3.12.1 9.10.4.6 9.4.1.2 9.1.4.8	21 16 9 12	58
Fig 4	8.6.4.3 9.11.1.6 9.2.3.6 9.9.3.8	13 3 12 17	45
Fig 5	2.2.5.1	22	22
Fig 6	1.3.14.1 9.1.1.2 9.2.4.8 9.2.1.4	22 8 15 13	58
Fig 7	1.3.6.4 9.1.4.6 9.1.1.1 9.1.1.3 9.1.4.4	19 10 6 10 8	53
Fig 8	5.2.1.1 9.9.5.8 9.10.6.4	17 17 19	53
Fig 9	7.2.2.1 9.1.3.8 9.4.3.4 9.1.3.6	6 12 11 10	39
Total K = 420			



WAC 2013		Form B
Pilot ID	unlimited Programme free	Flight #



Power			
Fig 1	5.2.1.1 9.9.1.4 9.2.5.4	17 15 9	41
Fig 2	1.3.14.1 9.1.1.2 9.9.4.8 9.4.1.4	22 8 17 15	62
Fig 3	1.3.11.4 9.10.10.4 9.1.2.6 9.1.5.4	20 15 12 8	55
Fig 4	6.2.2.1 9.1.1.4 9.1.5.1	15 12 2	29
Fig 5	1.3.11.1 9.1.1.1 9.10.4.2 9.1.4.8	20 6 13 12	51
Fig 6	7.8.16.4 9.1.4.2 9.2.4.4 9.2.4.6 9.4.4.2	24 4 9 12 5	54
Fig 7	1.3.13.1 9.4.1.2 9.9.4.4 9.2.1.4	22 9 11 13	55
Fig 8	8.6.3.3 9.11.1.6 9.2.3.6 9.9.3.6	13 3 12 14	42
Fig 9	2.3.4.2	31	31
Total K = 420			

Jerzy Strzyż pilot
 Sukhoi 26 C-GSUK A/C



Pilot ID #

Unlimited Free

Flight #

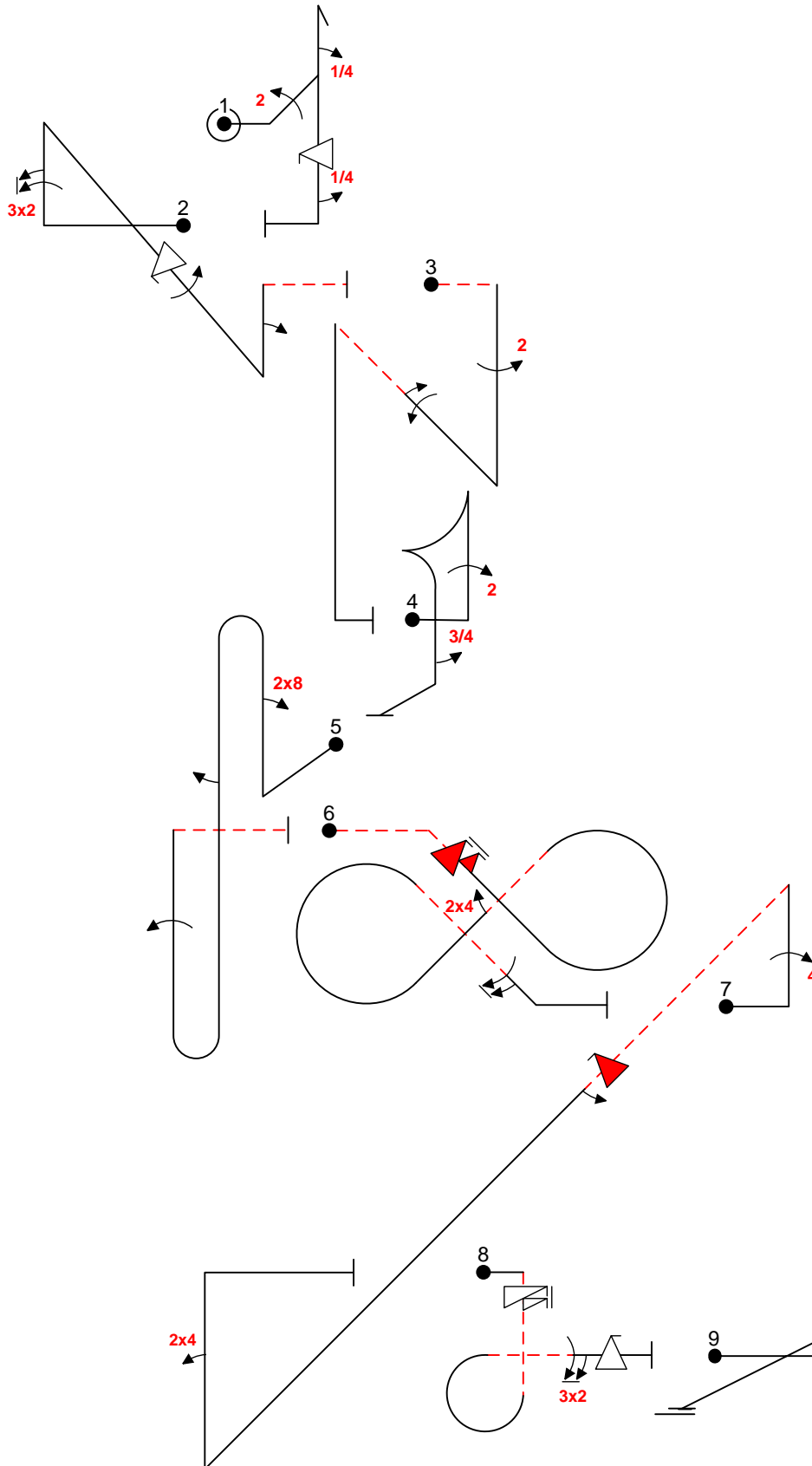
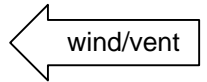

Fig 1	5.3.1.1	18	48
	9.2.2.4	11	
	9.1.1.1	6	
	9.9.5.4	11	
	9.1.5.1	2	
Fig 2	1.3.14.1	22	66
	9.2.1.6	17	
	9.9.4.4	11	
	9.1.4.4	8	
	9.1.1.2	8	
Fig 3	1.3.11.4	20	45
	9.2.5.4	9	
	9.1.2.4	10	
	9.1.2.2	6	
Fig 4	6.2.1.1	15	34
	9.2.1.4	13	
	9.1.5.3	6	
Fig 5	8.8.1.1	18	41
	9.8.1.1	7	
	9.1.5.2	4	
	9.1.1.4	12	
Fig 6	7.8.16.4	24	55
	9.10.4.6	16	
	9.4.4.2	5	
	9.1.4.6	10	
Fig 7	1.3.12.1	21	62
	9.4.1.4	15	
	9.10.4.4	13	
	9.1.4.2	4	
	9.4.1.2	9	
Fig 8	8.6.4.3	13	39
	9.11.1.6	3	
	9.2.3.6	12	
	9.9.3.4	11	
Fig 9	2.3.4.1	30	30

Total K = 420

Pilot ID #

Unlimited Free

Flight #

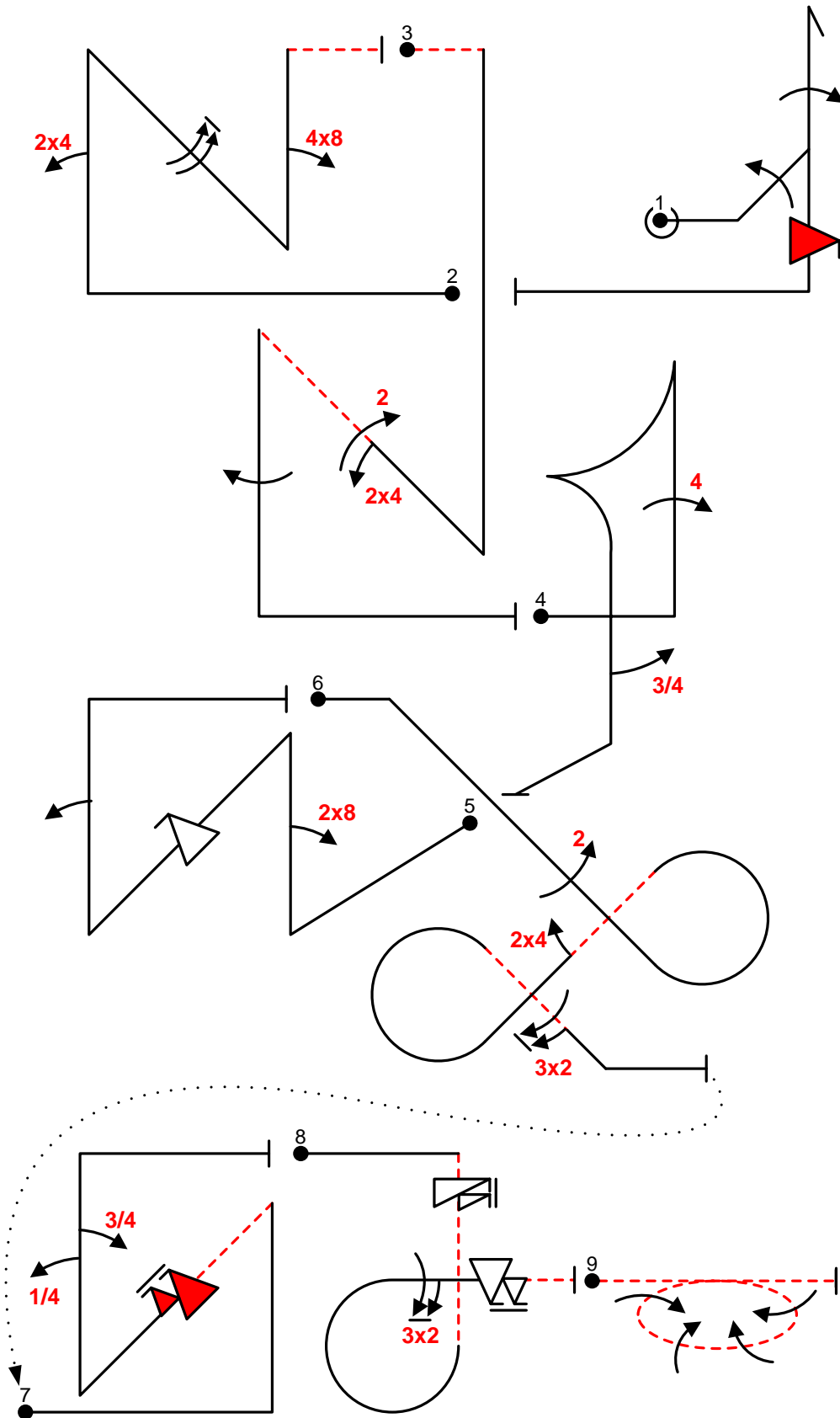
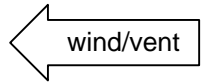
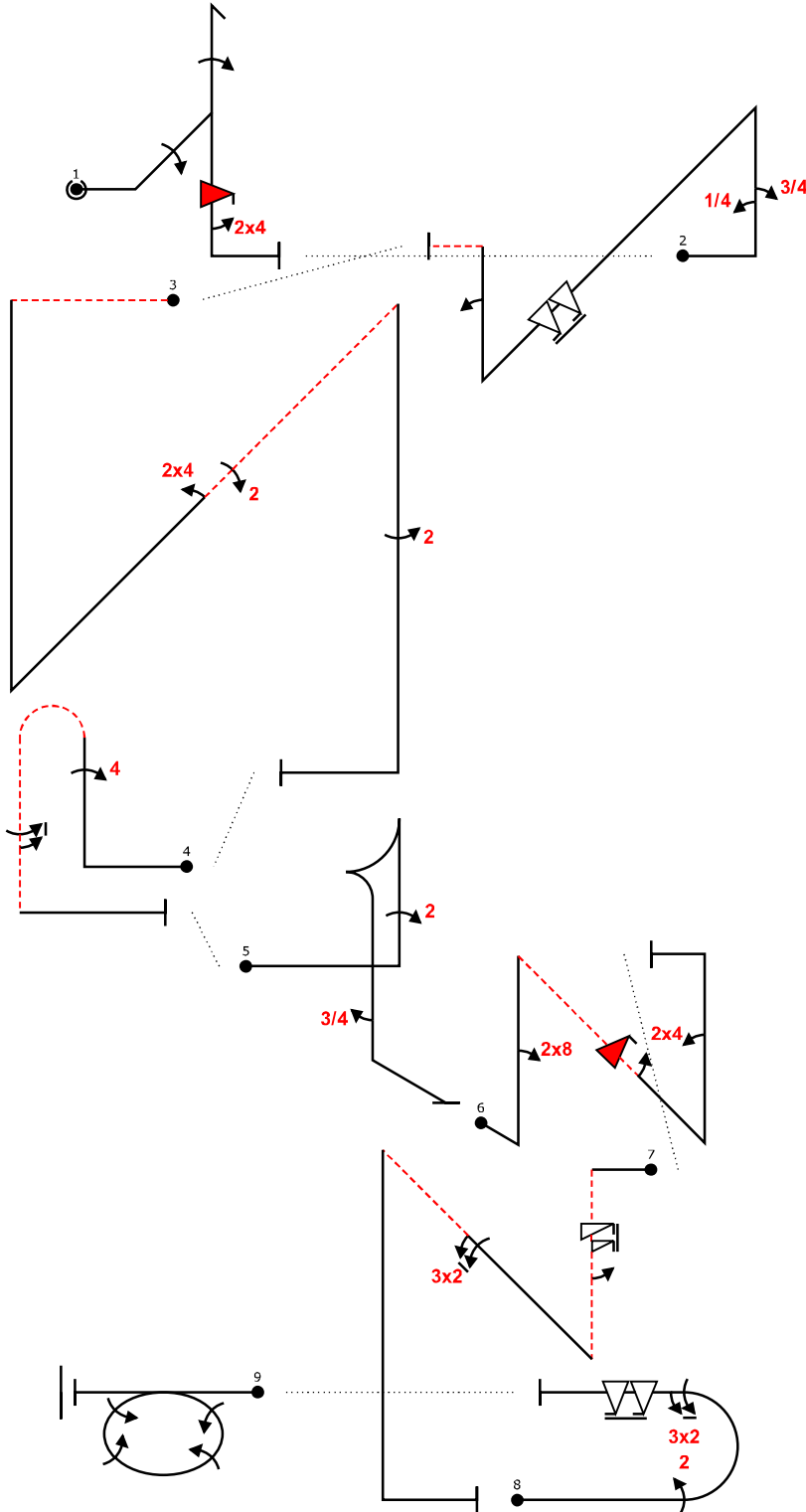
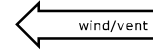

Fig 1	9.1.2.4 9.1.1.4 5.3.1.1 9.10.5.4	10 12 18 13	53
Fig 2	1.3.14.1 9.4.1.2 9.1.4.8 9.8.1.2	22 9 11 12	54
Fig 3	1.3.11.4 9.2.2.4 9.1.5.4 9.4.2.2	20 11 8 7	46
Fig 4	6.2.1.1 9.4.1.4 9.1.5.3	15 15 6	36
Fig 5	1.3.13.1 9.8.1.1 9.9.4.4 9.1.1.2	22 7 11 8	48
Fig 6	7.8.15.3 9.2.4.4 9.2.4.6 9.4.4.2	23 9 12 5	49
Fig 7	1.3.12.1 9.10.4.6 9.1.1.1 9.1.1.3	21 16 6 10	53
Fig 8	8.6.3.3 9.11.1.6 9.2.3.6 9.9.3.6	13 3 12 14	42
Fig 9	2.4.7.2	39	39

Total K = 420



WAC 2013		Form B
Pilot ID	Unlimited Programme Free	
		Flight #



Power			
Fig 1	5.3.1.1	18	58
	9.1.2.4	10	
	9.1.1.4	12	
	9.10.5.4	13	
	9.4.5.2	5	
Fig 2	1.3.14.1	22	63
	9.1.1.1	6	
	9.1.1.3	10	
	9.9.4.8	17	
	9.1.1.2	8	
Fig 3	1.3.11.4	20	47
	9.4.2.2	7	
	9.2.2.4	11	
	9.2.5.4	9	
Fig 4	8.4.3.1	15	40
	9.4.1.4	15	
	9.1.5.6	10	
Fig 5	6.2.1.1	15	34
	9.2.1.4	13	
	9.1.5.3	6	
Fig 6	1.3.12.1	21	54
	9.8.1.1	7	
	9.10.4.4	13	
	9.1.4.2	4	
	9.4.1.2	9	
Fig 7	1.3.16.3	21	+2
	9.11.1.6	3	
	9.1.5.2	4	
	9.2.2.6	14	
Fig 8	7.2.2.1	6	44
	9.2.3.4	9	
	9.2.3.6	12	
	9.9.3.8	17	
Fig 9	2.4.7.1	38	38
Total K = 420			

Martin Sonka Pilot
Extra 300SR A/C



north intl Texas october 2013		Form B
Pilot ID	Unlimited Programme Free	Flight #

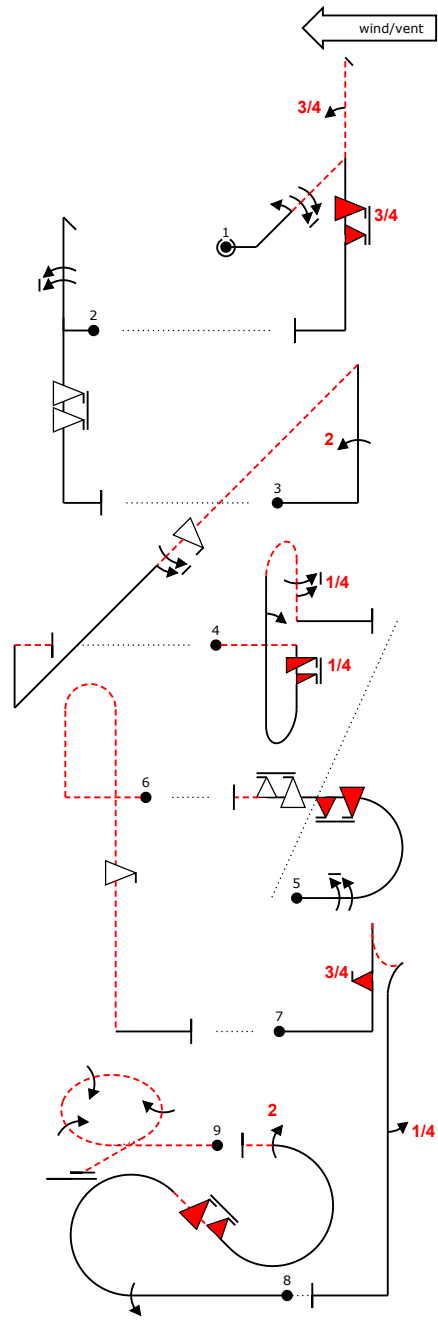

Francois LE VOT
pilot
Ex 330 SC F-TGCJ
A/C



Pilot ID		Form B
Unlimited Programme Free		Flight #

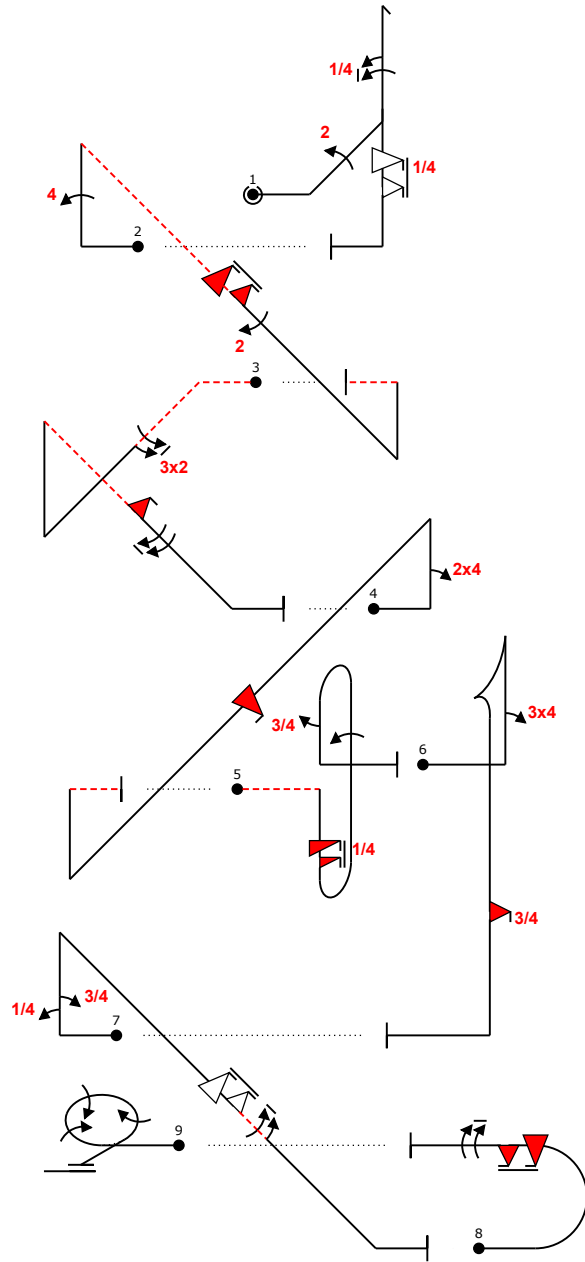
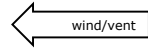

Power			
Fig 1	5.3.1.1	18	56
	9.2.2.4	11	
	9.1.1.5	14	
	9.9.5.5	13	
Fig 2	1.3.11.1	20	60
	9.4.1.4	15	
	9.10.4.6	16	
	9.2.4.4	9	
Fig 3	1.3.4.4	18	55
	9.2.4.6	12	
	9.10.4.2	13	
	9.1.4.8	12	
Fig 4	1.3.14.1	22	46
	9.4.1.2	9	
	9.10.9.4	15	
Fig 5	8.8.1.4	18	42
	9.12.1.5	6	
	9.1.1.4	12	
	9.1.5.3	6	
Fig 6	6.2.1.1	15	40
	9.4.1.3	12	
	9.10.5.3	13	
Fig 7	1.2.6.1	14	54
	9.1.1.1	6	
	9.1.1.3	10	
	9.9.4.6	14	
	9.1.4.6	10	
Fig 8	7.2.2.1	6	37
	9.10.8.6	19	
	9.1.3.8	12	
Fig 9	2.3.4.1	30	30
Total K = 420			

22dh(5)5f" [-11,0] 44`n(..'6if,22...)"`'- [-3,0] -'32iw(')2if,9. [3,0] `24`pn(...if.....)`'- [5,0] -`5isibb(1),3 > ``+',34ta..'3if..' [-17,0] ````4,3'k...6f;6.' [0,0] m6if,9 [-14,0] -3% 3j3

Lemordant pilot
cap232 F-HERA
A/C



Sherman / Texas Oct 2013		Form B
Pilot ID	unlimited Programme free	Flight #

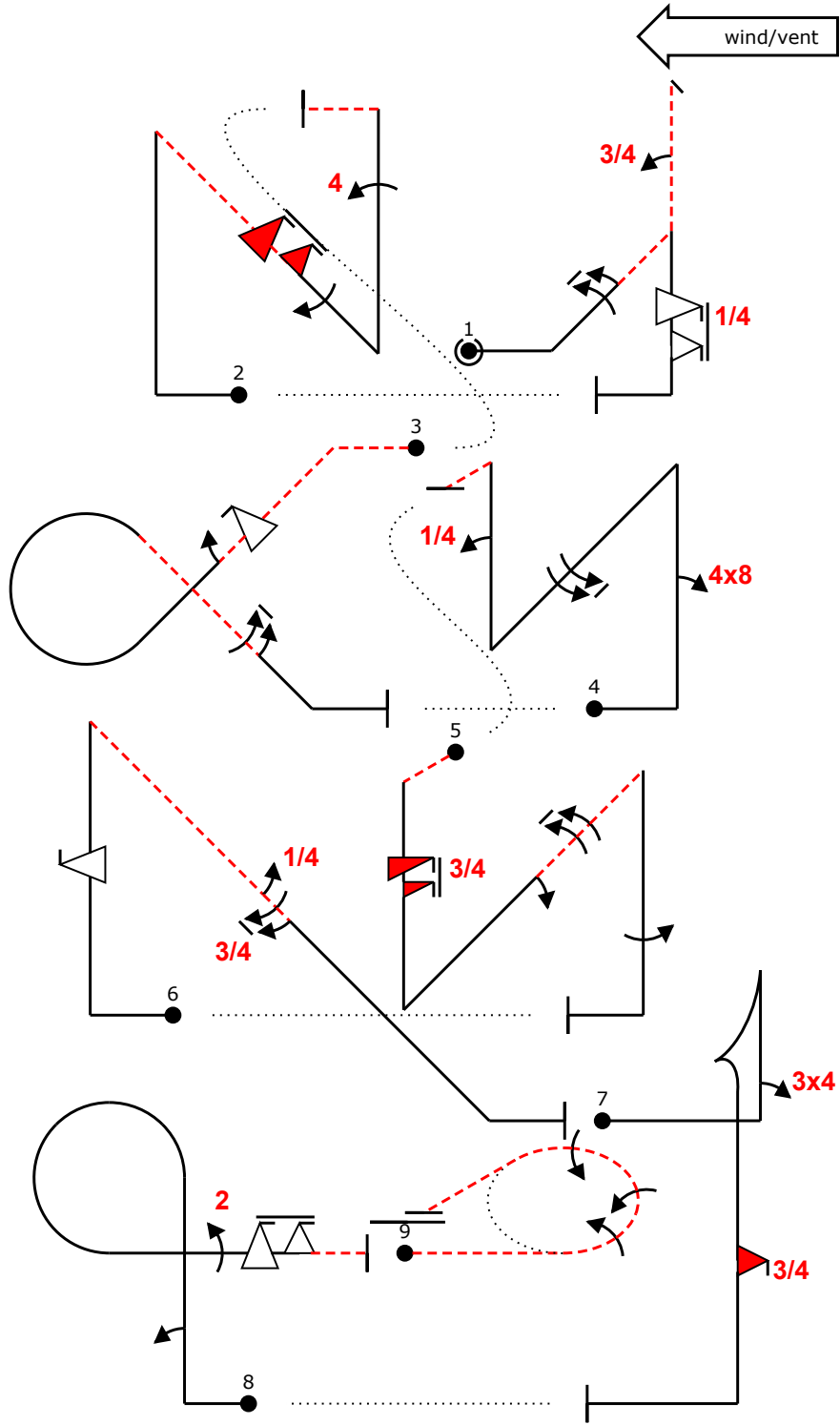

Pierre Varloteaux
pilote
Extra 330 SC
A/C



SHERMAN 2013		Form B
Pilot ID	Unlimited Programme Free	Flight #

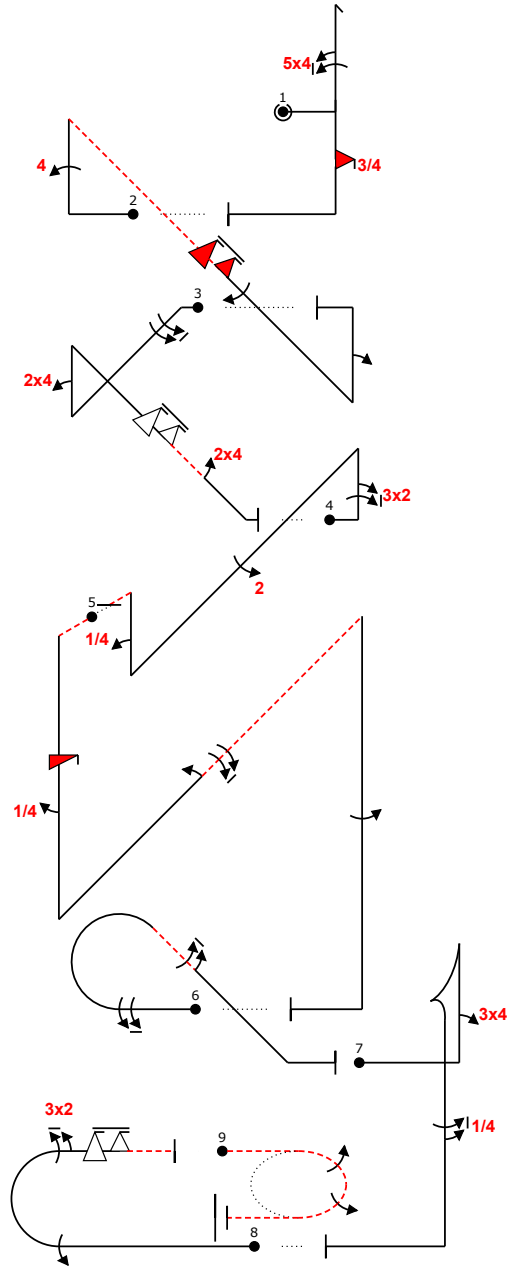
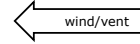

Power			
Fig 1	5.2.1.1 9.4.1.5 9.10.5.3	17 18 13	48
Fig 2	1.3.12.1 9.4.1.4 9.10.4.6 9.1.4.4 9.1.1.2	21 15 16 8 8	68
Fig 3	1.3.5.3 9.1.4.8 9.4.1.2 9.9.4.6 9.4.4.2	19 12 9 14 5	59
Fig 4	1.3.14.1 9.2.1.6 9.2.4.4 9.1.1.1	22 17 9 6	54
Fig 5	1.3.11.4 9.12.1.4 9.1.5.1 9.1.2.2 9.1.2.8 9.1.5.4	20 7 2 6 15 8	58
Fig 6	8.5.6.1 9.1.3.8 9.1.4.6	10 12 10	32
Fig 7	6.2.1.1 9.4.1.3 9.1.5.5	15 12 9	36
Fig 8	7.2.1.1 9.1.3.4 9.2.3.6 9.9.3.6	6 8 12 14	40
Fig 9	2.2.5.4	25	25
Total K = 420			

54h'3if'+~ [-4,0] ~44`n(..'6if,1...)` ,2+` [-6,0] ` ` ` +9iw(` 24`)'6f";24'+` ` ` [2,0] ` ` +` ,32` ` pn(..22...)` ` 4-` [2,-1] -..is",4.in(...2',9....)... "1....~ [-4,0] ` ` ` ` ` +` 9c'6" ,34 ta'5` ,~ [-2.0] +++++1m32:6f- [0.0] -2in2-

rallet Pilot
FTGCI A/C



		Form B
Pilot ID	Unlimited Programme Programme2	Flight #

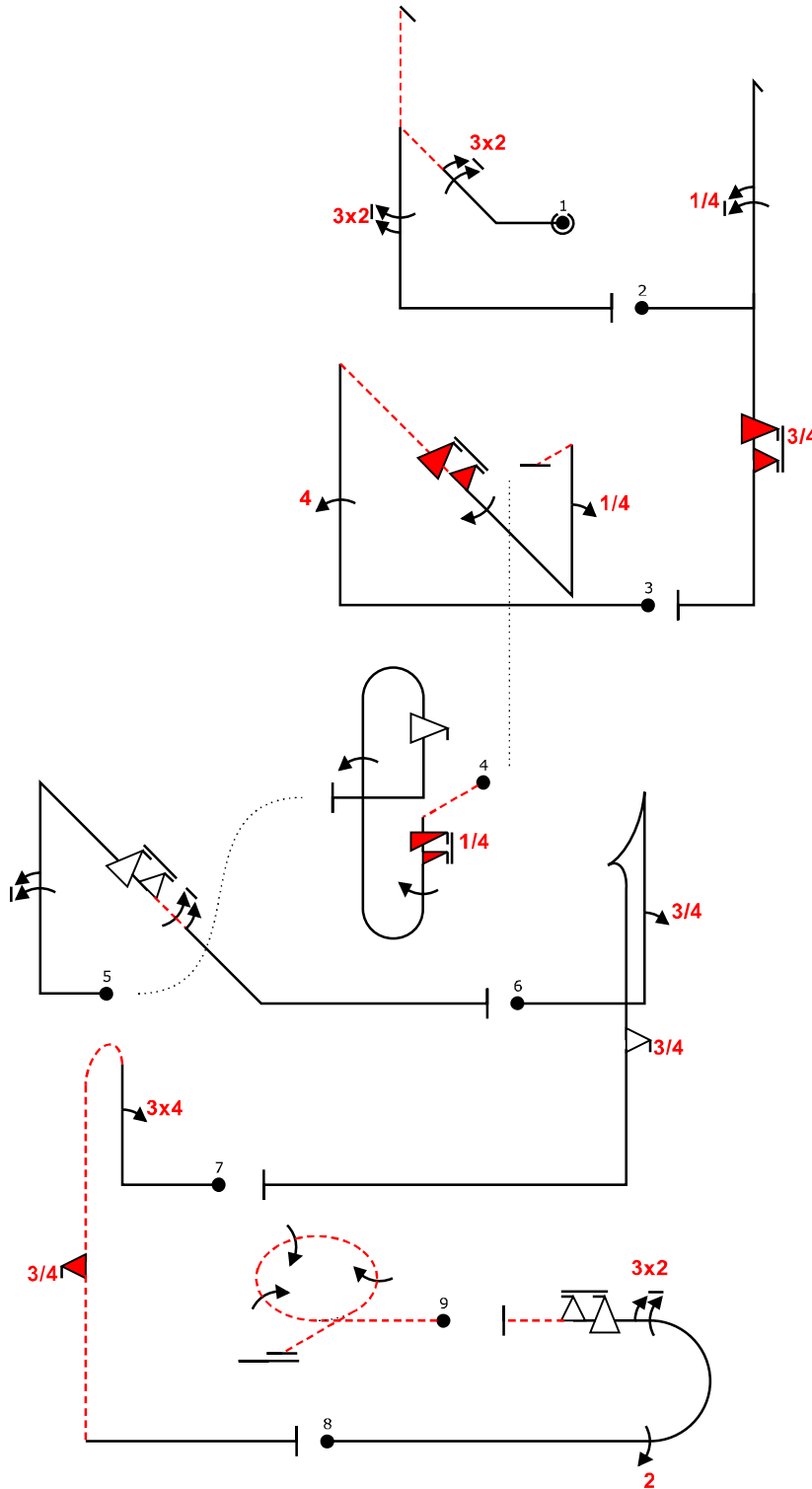
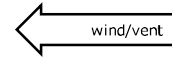

Power			
Fig 1	5.3.2.1	24	50
	9.2.2.6	14	
	9.2.5.6	12	
Fig 2	5.2.1.1	17	49
	9.1.1.5	14	
	9.10.5.7	18	
Fig 3	1.3.11.1	20	65
	9.4.1.4	15	
	9.10.4.6	16	
	9.1.4.4	8	
	9.1.1.1	6	
Fig 4	8.8.1.4	18	55
	9.12.1.5	6	
	9.1.5.4	8	
	9.1.1.4	12	
	9.9.5.4	11	
Fig 5	1.2.6.1	14	53
	9.1.1.6	15	
	9.9.4.6	14	
	9.1.4.6	10	
Fig 6	6.2.1.1	15	36
	9.1.1.3	10	
	9.9.5.3	11	
Fig 7	8.4.3.1	15	40
	9.4.1.3	12	
	9.10.5.3	13	
Fig 8	7.2.1.1	6	41
	9.2.3.4	9	
	9.2.3.6	12	
	9.9.3.6	14	
Fig 9	2.3.4.2	31	31
Total K = 420			

Tom Bennett Pilot
CAP232, G-11A1 A/C



WAC 2013		Form B
Pilot ID	Unlimited Programme Programme2	Flight #

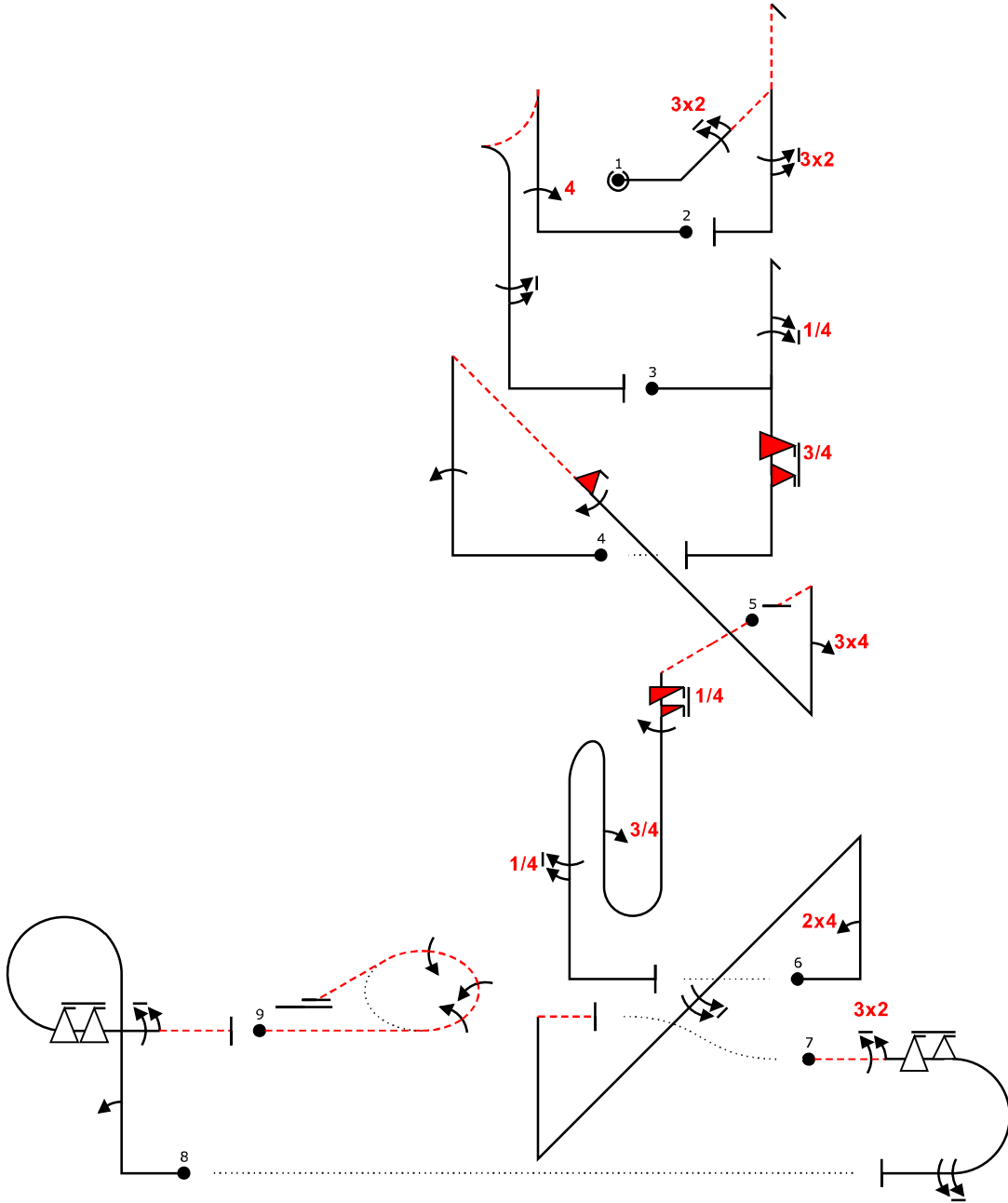
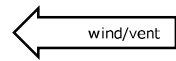

Power			
Fig 1	5.3.2.1 9.2.2.6 9.2.5.6	24 14 12	50
Fig 2	6.2.2.1 9.4.1.4 9.1.5.6	15 15 10	40
Fig 3	5.2.1.1 9.1.1.5 9.10.5.7	17 14 18	49
Fig 4	1.3.11.1 9.1.1.4 9.10.4.2 9.1.4.4 9.4.1.3	20 12 13 8 12	65
Fig 5	8.8.1.4 9.12.1.5 9.1.5.4 9.1.1.3 9.1.5.5	18 6 8 10 9	51
Fig 6	1.3.14.1 9.4.1.2 9.1.4.8	22 9 12	43
Fig 7	7.2.1.4 9.2.3.6 9.9.3.6 9.1.3.8	6 12 14 12	44
Fig 8	8.6.2.1 9.1.1.2 9.9.3.8 9.1.3.6	12 8 17 10	47
Fig 9	2.3.4.2	31	31
Total K = 420			

Gerald Cooper v2
 Pilot
 XA 41, G-IIRI
 A/C

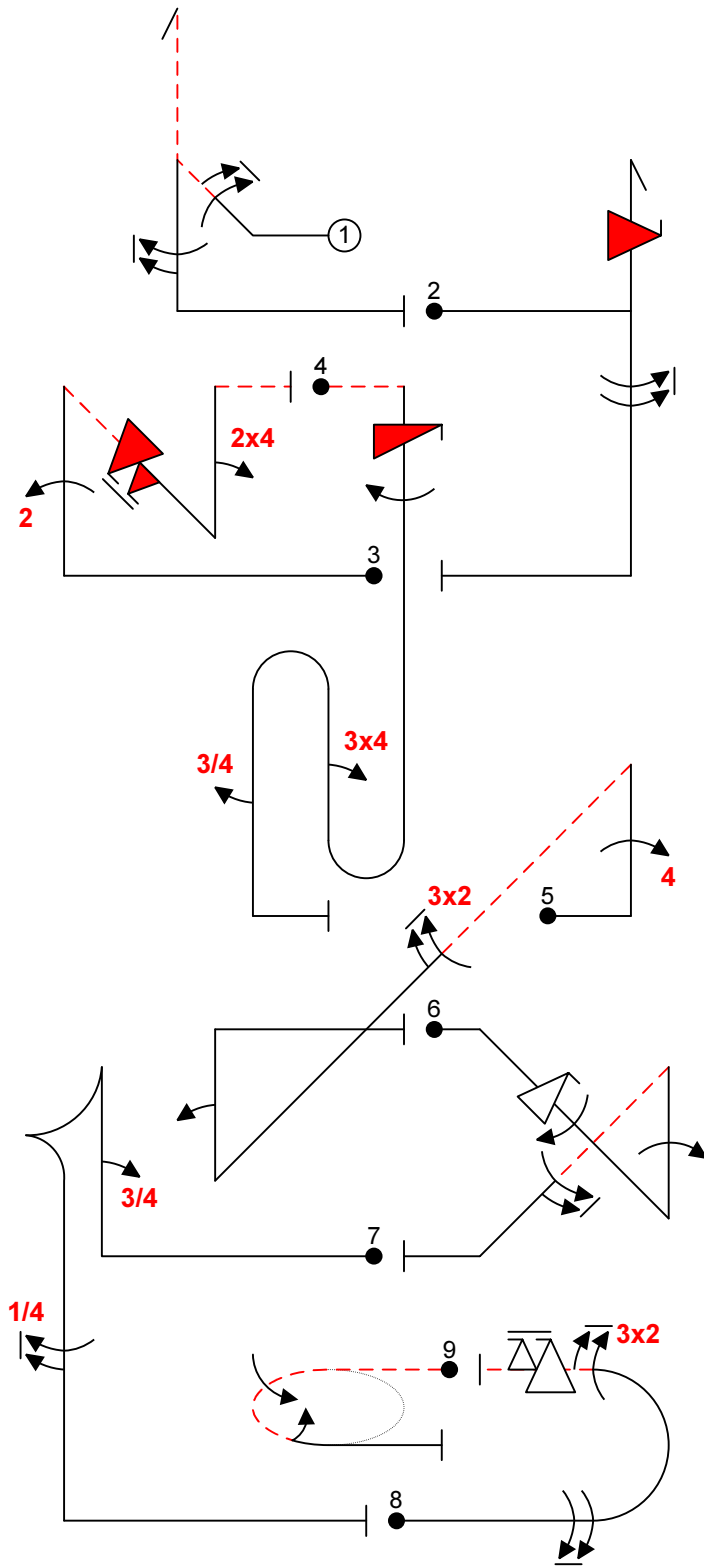
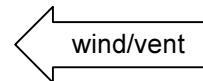
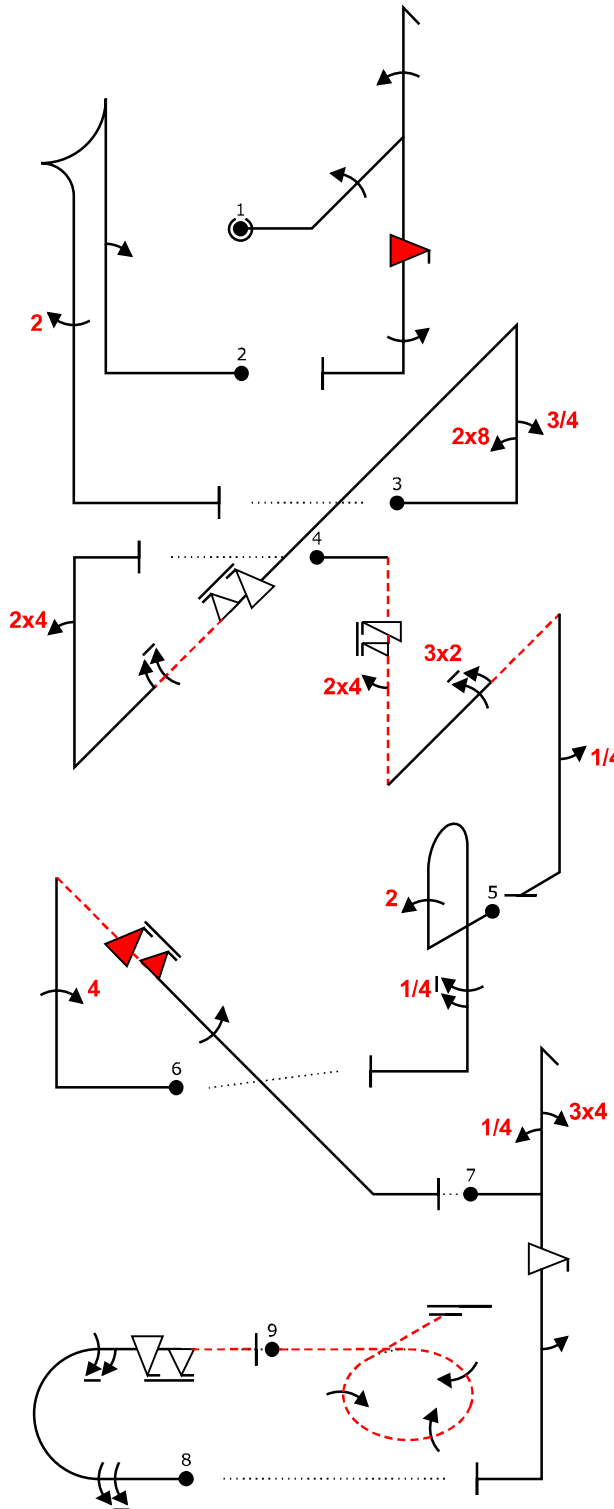
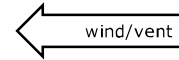

Fig 1	5.3.2.1 9.1.2.6 9.1.5.6	24 12 10	46
Fig 2	5.2.1.1 9.10.6.4 9.1.5.8	17 19 12	48
Fig 3	1.3.11.1 9.2.1.4 9.10.4.6 9.4.1.2	20 13 16 9	58
Fig 4	8.8.1.4 9.12.1.4 9.1.5.4 9.4.1.3 9.1.5.3	18 7 8 12 6	51
Fig 5	1.3.12.1 9.4.1.4 9.2.4.6 9.1.1.2	21 15 12 8	56
Fig 6	1.3.3.3 9.9.4.4 9.1.4.4 9.1.1.4 9.1.4.6	18 11 8 12 10	59
Fig 7	6.2.1.1 9.1.1.3 9.1.5.5	15 10 9	34
Fig 8	7.2.1.1 9.2.3.6 9.9.3.6 9.1.3.8	6 12 14 12	44
Fig 9	2.2.3.2	24	24
Total K = 420			

Simon Johnson GBR
Extra 330SC
pilot
A/C



WAC 2013		Form B
Pilot ID	Unlimited Programme Free	
		Flight #



Power			
Fig 1	5.3.1.1	18	61
	9.1.2.4	10	
	9.1.1.4	12	
	9.10.5.4	13	
	9.1.5.4	8	
Fig 2	6.2.1.1	15	32
	9.1.1.2	8	
	9.2.5.4	9	
Fig 3	1.3.13.1	22	72
	9.8.1.1	7	
	9.1.1.3	10	
	9.9.4.6	14	
	9.1.4.6	10	
Fig 4	9.4.1.2	9	45
	1.3.16.3	21	
	9.11.1.6	3	
	9.4.5.2	5	
	9.2.2.6	14	
Fig 5	9.1.5.1	2	35
	8.4.1.1	13	
	9.2.1.4	13	
Fig 6	9.1.5.5	9	52
	1.2.7.1	13	
	9.4.1.4	15	
	9.10.4.6	16	
Fig 7	9.1.4.4	8	50
	5.2.1.1	17	
	9.1.1.1	6	
	9.4.1.3	12	
Fig 8	9.9.5.4	11	42
	9.1.5.2	4	
	7.2.1.1	6	
	9.1.3.8	12	
Fig 9	9.1.3.6	10	31
	9.9.3.6	14	
	2.3.4.2	31	
Total K = 420			

Dagmar Kress
 Extra Pilot
 A/C

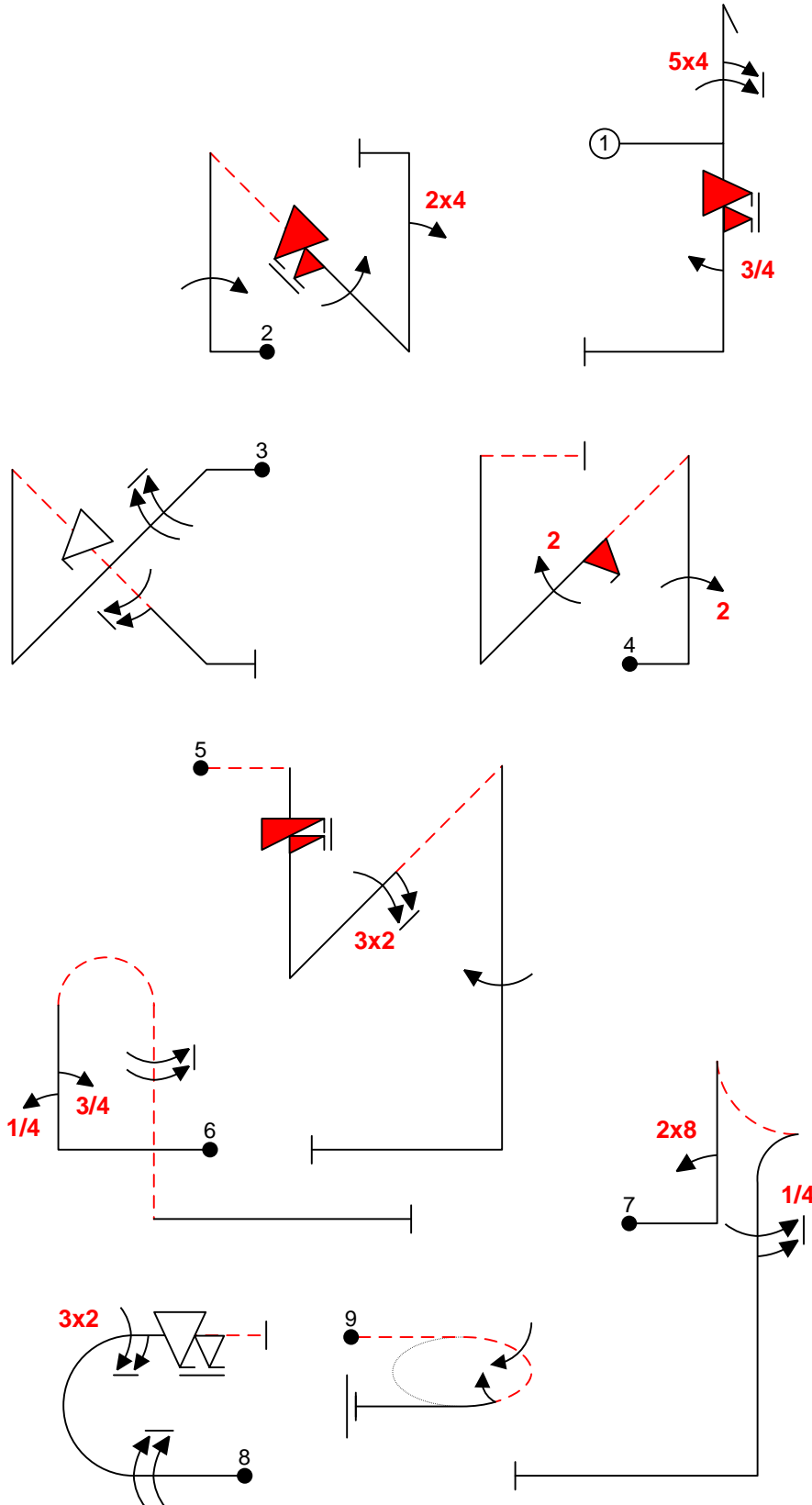
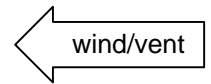

Fig 1	5.2.1.1 9.4.1.5 9.10.5.6 9.1.5.3	17 18 16 6	57
Fig 2	1.3.12.1 9.1.1.4 9.10.4.6 9.1.4.4 9.4.1.2	21 12 16 8 9	66
Fig 3	1.3.3.3 9.1.4.8 9.9.9.4 9.1.4.6	18 12 13 10	53
Fig 4	1.3.11.1 9.2.1.4 9.10.4.2 9.2.4.4	20 13 13 9	55
Fig 5	1.3.11.4 9.12.1.6 9.2.2.6 9.1.5.4	20 5 14 8	47
Fig 6	8.4.3.1 9.1.1.1 9.1.1.3 9.1.5.8	15 6 10 12	43
Fig 7	6.2.2.1 9.8.1.1 9.1.5.5	15 7 9	31
Fig 8	7.2.1.1 9.1.3.8 9.2.3.6 9.9.3.6	6 12 12 14	44
Fig 9	2.2.3.2	24	24
Total K = 420			

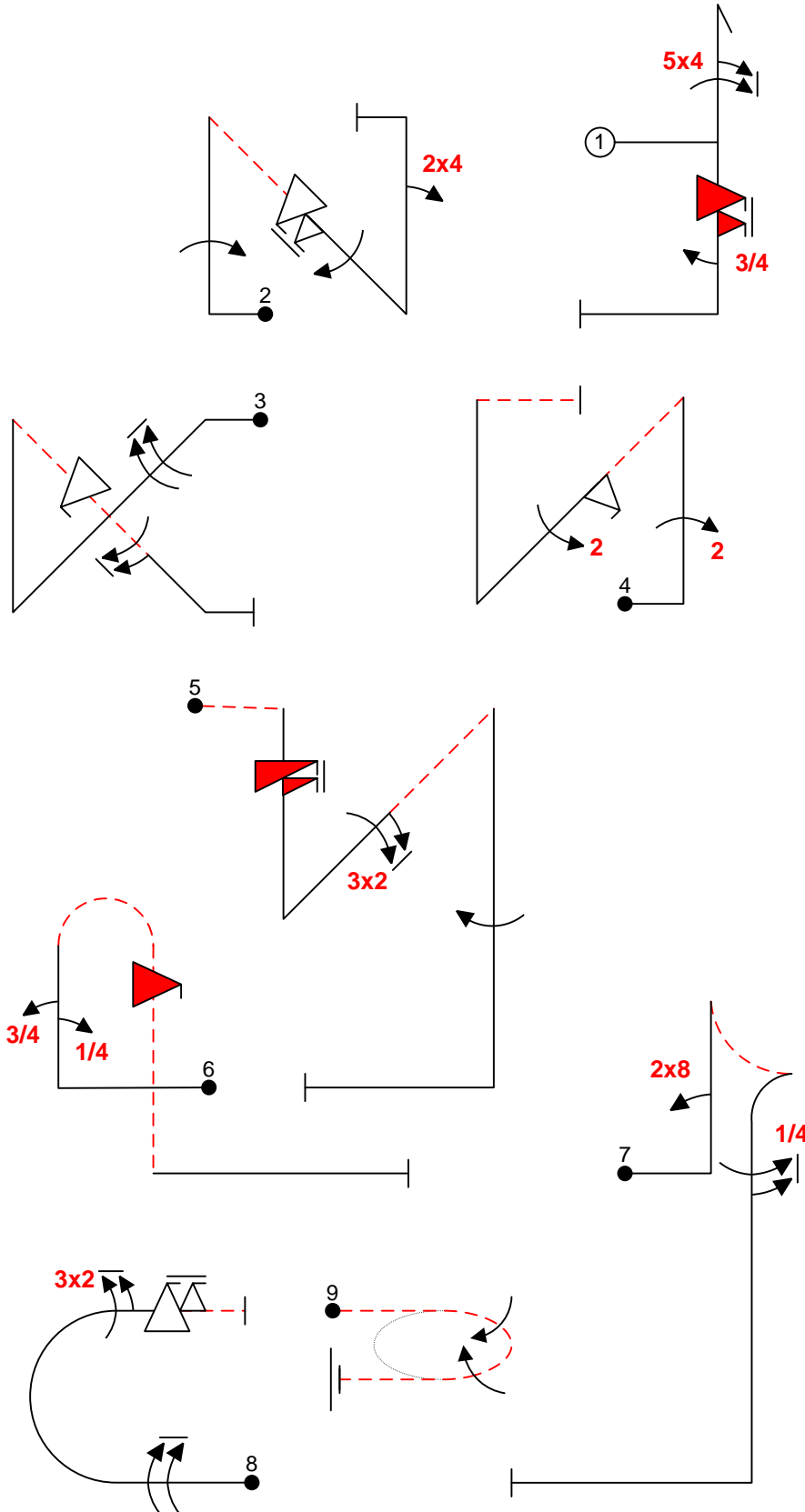
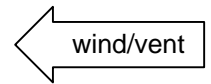
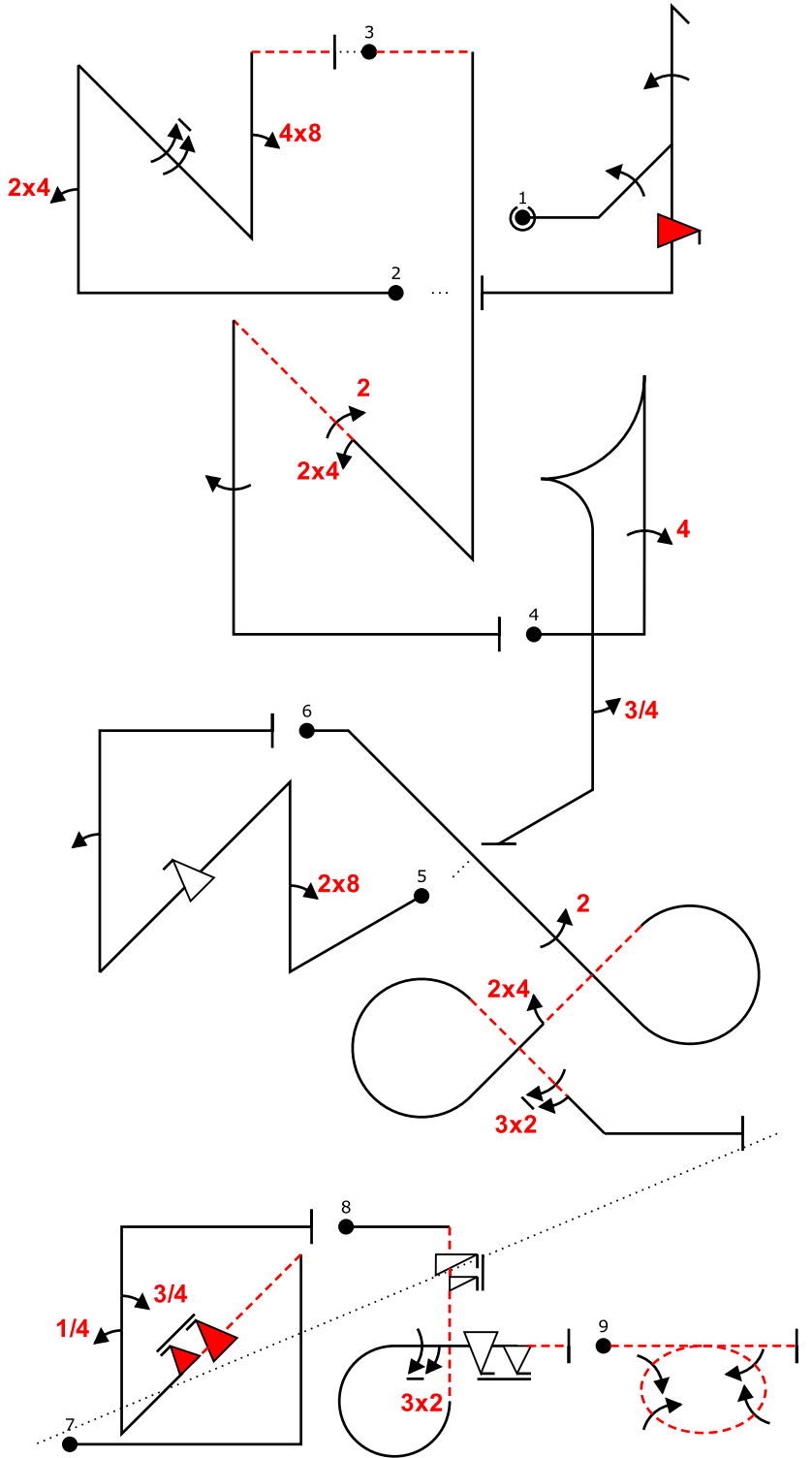
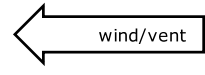

Fig 1	5.2.1.1 9.4.1.5 9.10.5.6 9.1.5.3	17 18 16 6	57
Fig 2	1.3.12.1 9.1.1.4 9.9.9.6 9.1.4.4 9.4.1.2	21 12 16 8 9	66
Fig 3	1.3.3.3 9.1.4.8 9.9.9.4 9.1.4.6	18 12 13 10	53
Fig 4	1.3.11.1 9.2.1.4 9.9.9.2 9.2.4.4	20 13 13 9	55
Fig 5	1.3.11.4 9.12.1.6 9.2.2.6 9.1.5.4	20 5 14 8	47
Fig 6	8.4.3.1 9.1.1.1 9.1.1.3 9.10.5.4	15 6 10 13	44
Fig 7	6.2.2.1 9.8.1.1 9.1.5.5	15 7 9	31
Fig 8	7.2.1.1 9.1.3.8 9.2.3.6 9.9.3.6	6 12 12 14	44
Fig 9	2.2.5.2	23	23
Total K = 420			



WAC 2013		Form B
Pilot ID	Unlimited Programme Free	Flight #



Power			
Fig 1	5.3.1.1	18	53
	9.1.2.4	10	
	9.1.1.4	12	
	9.10.5.4	13	
Fig 2	1.3.14.1	22	54
	9.4.1.2	9	
	9.1.4.8	12	
	9.8.1.2	11	
Fig 3	1.3.11.4	20	46
	9.4.2.2	7	
	9.2.2.4	11	
	9.1.5.4	8	
Fig 4	6.2.1.1	15	36
	9.4.1.4	15	
	9.1.5.3	6	
Fig 5	1.3.13.1	22	48
	9.8.1.1	7	
	9.9.4.4	11	
	9.1.1.2	8	
Fig 6	7.8.15.3	23	49
	9.2.4.4	9	
	9.4.4.2	5	
	9.2.4.6	12	
Fig 7	1.3.12.1	21	53
	9.10.4.6	16	
	9.1.1.1	6	
	9.1.1.3	10	
Fig 8	8.6.3.3	13	42
	9.11.1.6	3	
	9.2.3.6	12	
	9.9.3.6	14	
Fig 9	2.4.7.2	39	39
Total K = 420			

ClaudiusSpiegel Pilot
 Extra 330SC N60DX A/C

Pilot ID #

Unlimited Free

Flight #

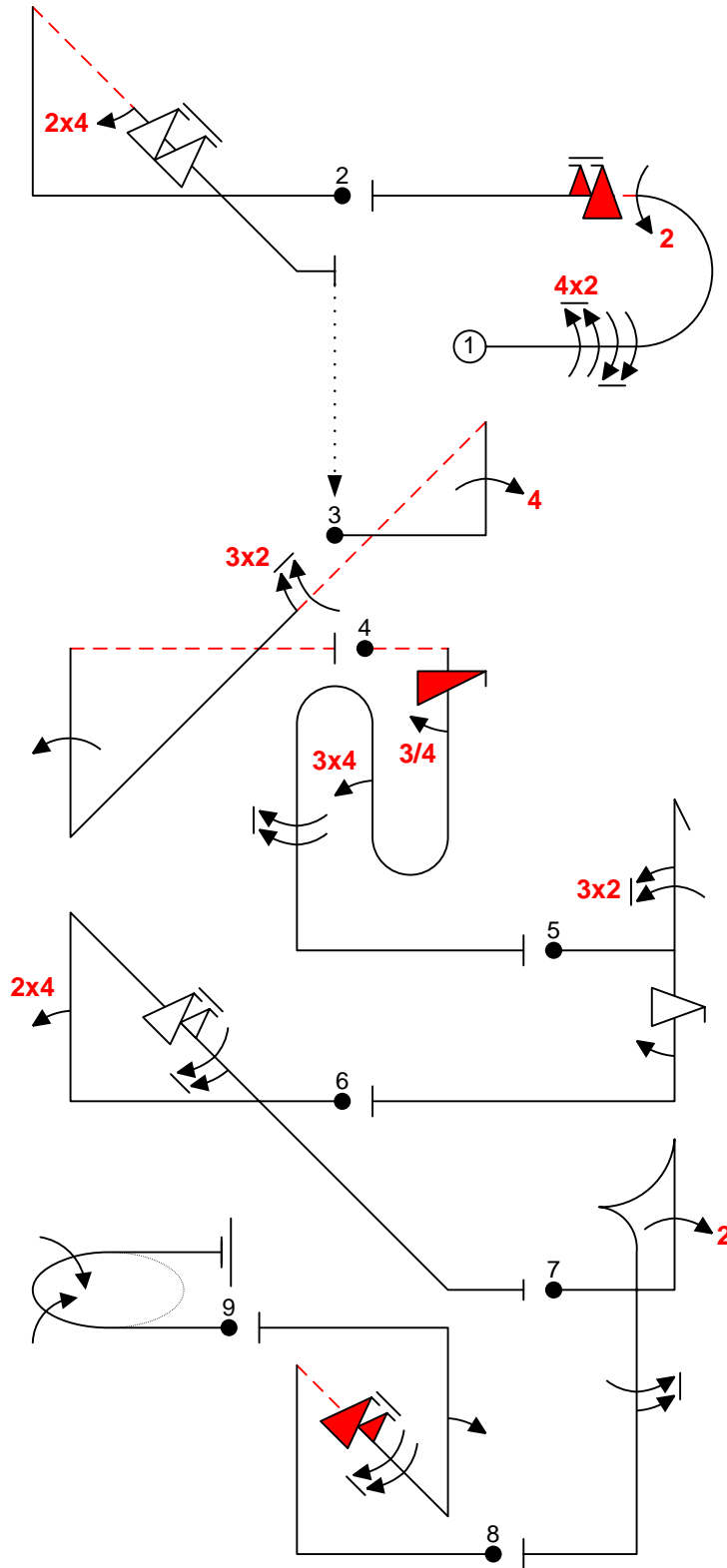
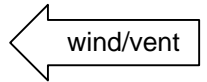

Fig 1	7.2.2.1	6	58
	9.2.3.8	15	
	9.1.3.8	12	
	9.2.3.4	9	
	9.10.3.6	16	
Fig 2	1.2.7.1	13	35
	9.4.4.2	5	
	9.9.4.8	17	
Fig 3	1.3.11.1	20	59
	9.4.1.4	15	
	9.2.4.6	12	
	9.1.1.4	12	
Fig 4	8.8.1.4	18	55
	9.12.1.4	7	
	9.1.5.3	6	
	9.4.1.3	12	
	9.1.5.8	12	
Fig 5	5.2.1.1	17	49
	9.2.1.6	17	
	9.9.5.4	11	
	9.1.5.2	4	
Fig 6	1.2.6.1	14	47
	9.4.1.2	9	
	9.9.4.6	14	
	9.1.4.6	10	
Fig 7	6.2.1.1	15	38
	9.2.1.4	13	
	9.1.5.6	10	
Fig 8	1.3.12.1	21	57
	9.10.4.6	16	
	9.1.4.8	12	
	9.1.1.2	8	
Fig 9	2.2.5.1	22	22
Total K = 420			

Pilot ID #

Unlimited Free

Flight #

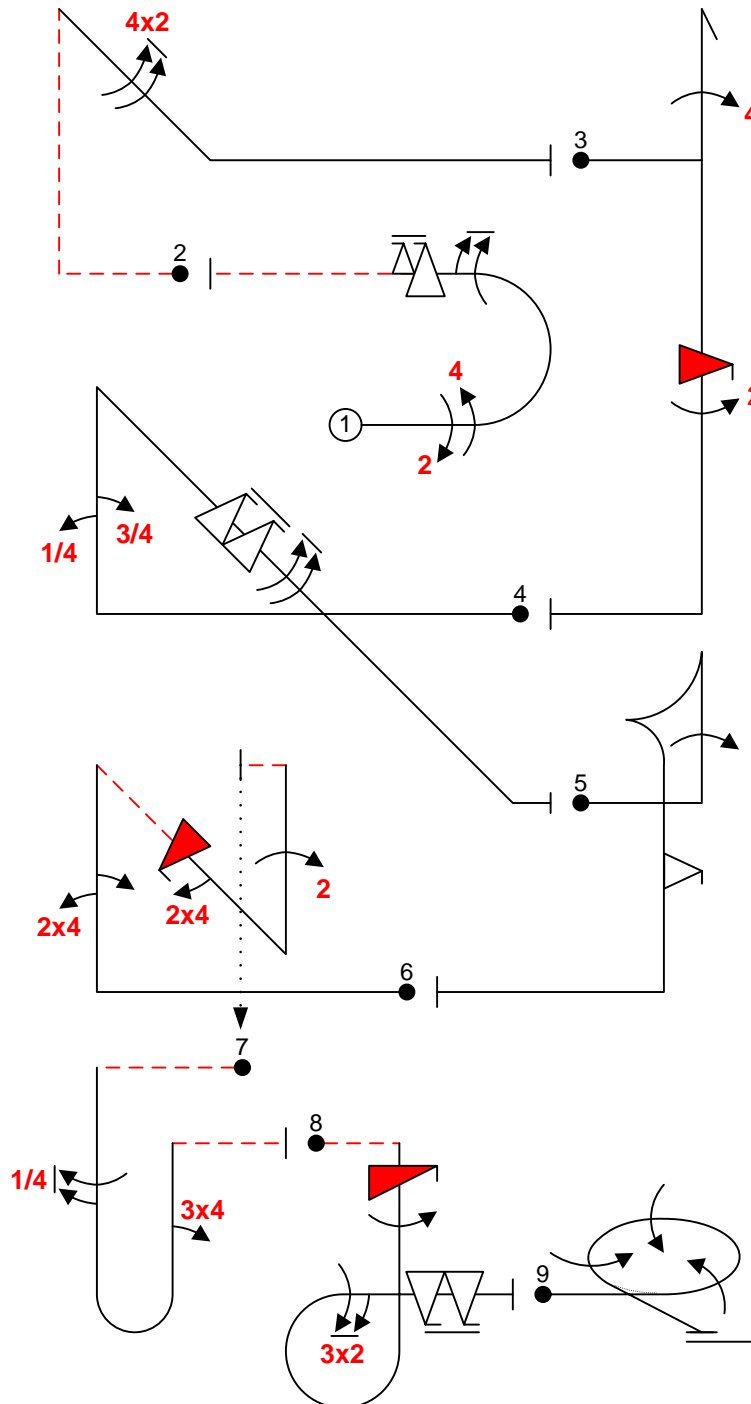
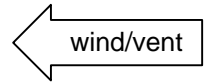

Fig 1	7.2.1.1	6	50
	9.2.3.4	9	
	9.4.3.4	11	
	9.1.3.6	10	
	9.9.3.6	14	
Fig 2	1.2.5.2	16	31
	9.2.4.8	15	
Fig 3	5.2.1.1	17	54
	9.4.1.4	15	
	9.10.5.4	13	
	9.2.5.4	9	
Fig 4	1.2.6.1	14	59
	9.1.1.1	6	
	9.1.1.3	10	
	9.9.4.8	17	
	9.1.4.8	12	
Fig 5	6.2.1.1	15	38
	9.1.1.4	12	
	9.9.5.2	11	
Fig 6	1.3.11.1	20	68
	9.4.1.2	9	
	9.1.1.2	8	
	9.10.4.4	13	
	9.4.4.2	5	
	9.2.1.4	13	
Fig 7	8.4.1.4	13	34
	9.1.5.5	9	
	9.4.1.3	12	
Fig 8	8.6.2.4	12	56
	9.12.1.4	7	
	9.1.5.4	8	
	9.2.3.6	12	
	9.9.3.8	17	
Fig 9	2.3.4.1	30	30
Total K = 420			

Pilot ID #

Unlimited Free

Flight #

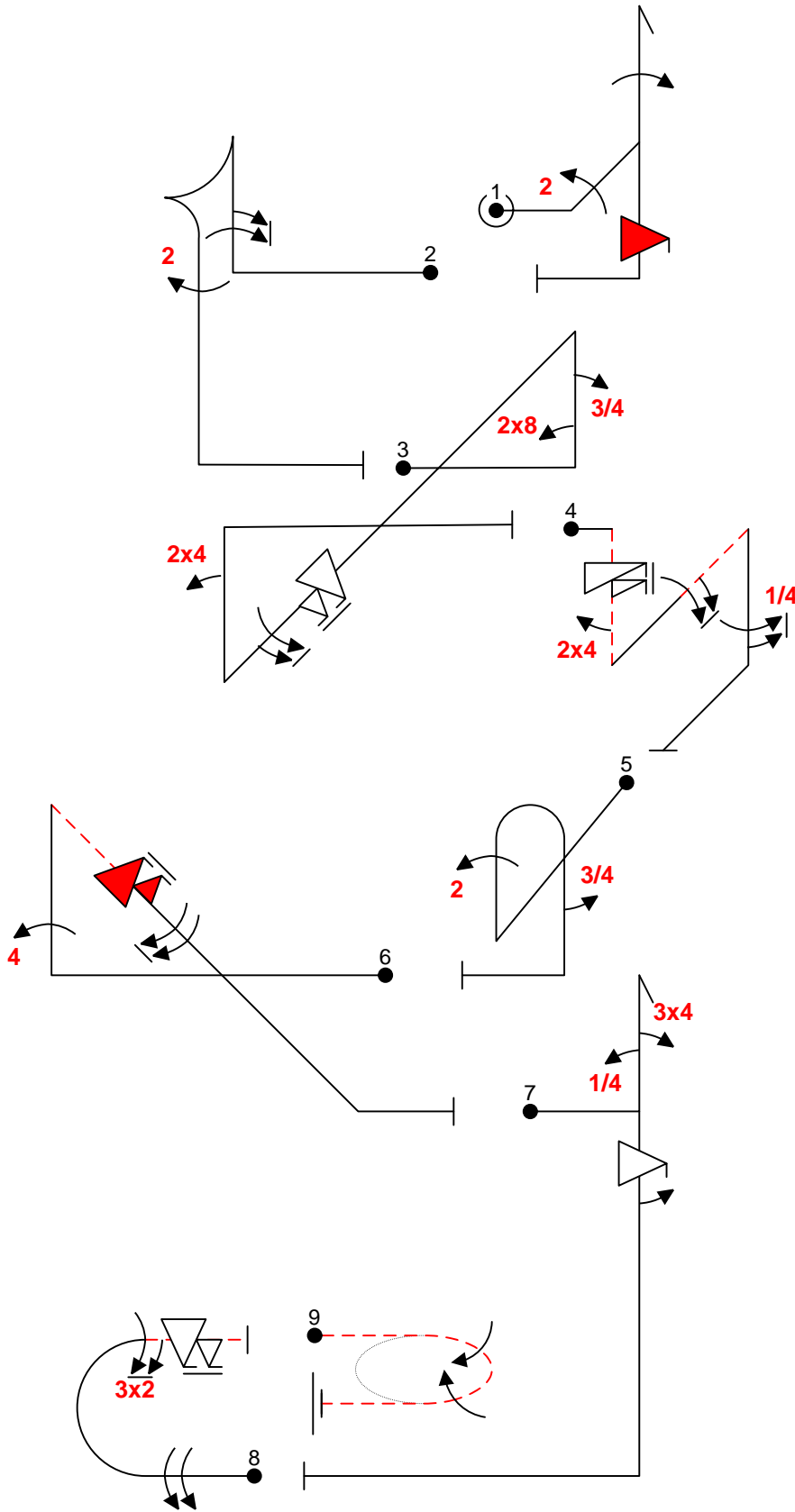
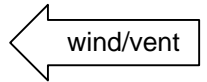

Fig 1	5.3.1.1 9.1.1.4 9.2.2.4 9.10.5.4	18 12 11 13	54
Fig 2	6.2.1.1 9.1.1.6 9.2.5.4	15 15 9	39
Fig 3	1.3.13.1 9.8.1.1 9.1.1.3 9.9.4.6 9.1.4.6 9.4.1.2	22 7 10 14 10 9	72
Fig 4	1.3.16.3 9.11.1.6 9.1.2.6 9.1.5.5 9.4.5.2	21 3 12 9 5	50
Fig 5	8.4.1.1 9.2.1.4 9.1.5.3	13 13 6	32
Fig 6	1.2.7.1 9.4.1.4 9.10.4.6 9.1.4.8	13 15 16 12	56
Fig 7	5.2.1.1 9.1.1.1 9.4.1.3 9.9.5.4 9.1.5.2	17 6 12 11 4	50
Fig 8	7.2.1.1 9.2.3.6 9.9.3.6 9.1.3.8	6 12 14 12	44
Fig 9	2.2.5.2	23	23

Total K = 420

Pilot ID #

Unlimited Free

Flight #

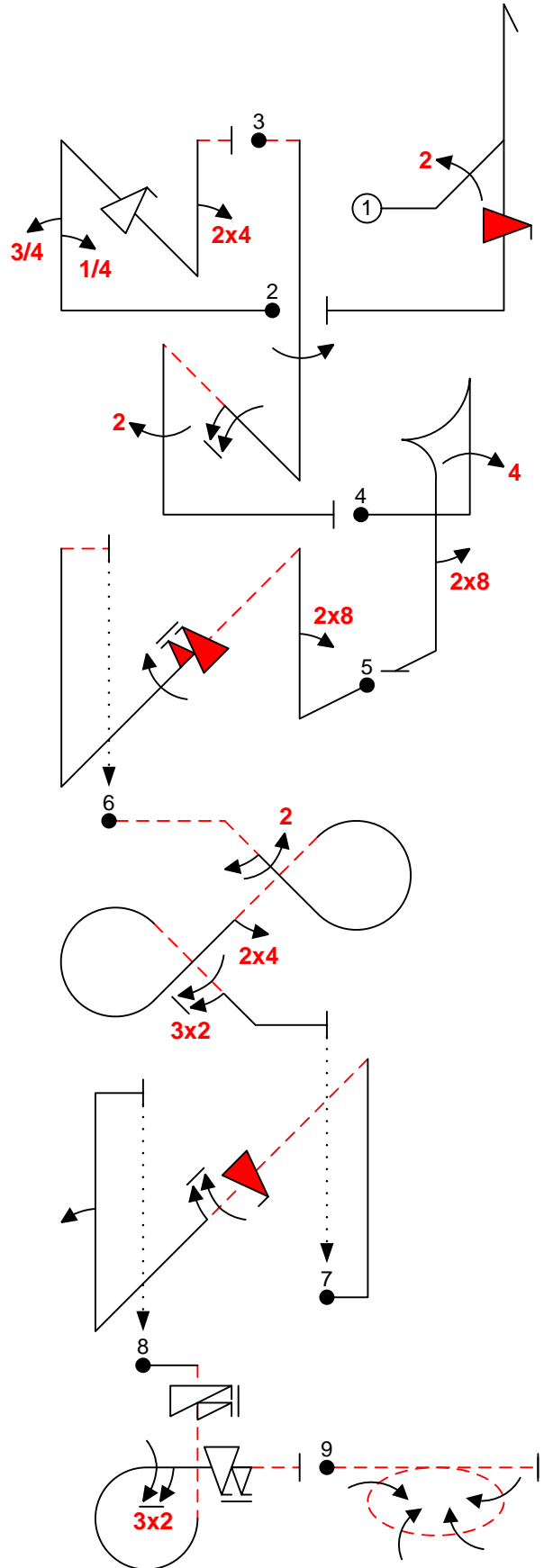
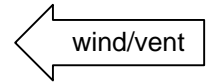
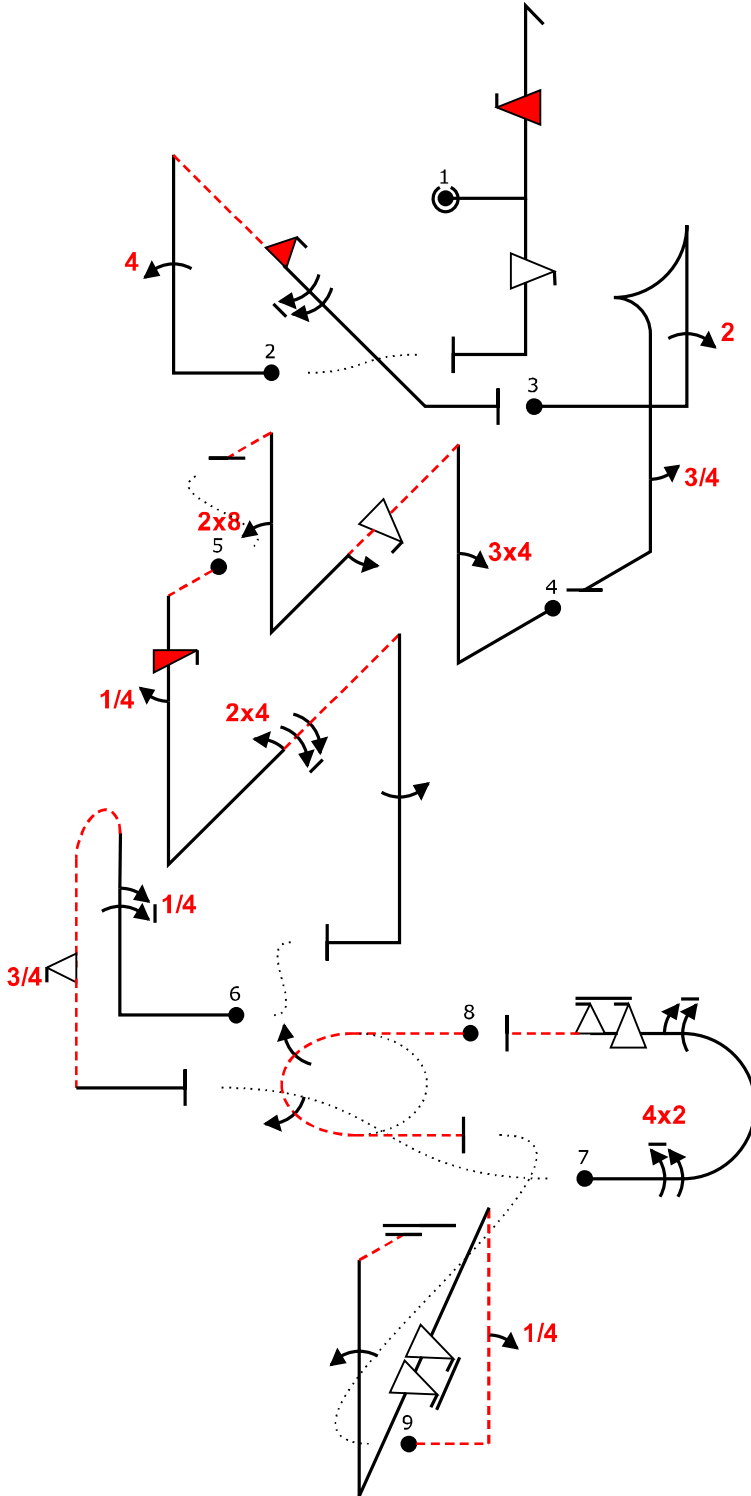
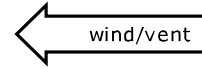

Fig 1	5.3.1.1	18	42
	9.2.2.4	11	
	9.10.5.4	13	
Fig 2	1.3.14.1	22	58
	9.1.1.1	6	
	9.1.1.3	10	
	9.9.4.4	11	
	9.4.1.2	9	
Fig 3	1.3.11.4	20	49
	9.1.5.4	8	
	9.1.2.6	12	
	9.2.5.4	9	
Fig 4	6.2.1.1	15	33
	9.4.1.4	15	
	9.8.5.1	3	
Fig 5	1.3.11.1	20	51
	9.8.1.1	7	
	9.10.4.6	16	
	9.1.4.4	8	
Fig 6	7.8.16.4	24	54
	9.1.4.2	4	
	9.2.4.4	9	
	9.4.4.2	5	
	9.2.4.6	12	
Fig 7	1.3.12.1	21	52
	9.10.4.4	13	
	9.1.4.6	10	
	9.1.1.2	8	
Fig 8	8.6.3.3	13	42
	9.11.1.6	3	
	9.2.3.6	12	
	9.9.3.6	14	
Fig 9	2.4.7.2	39	39
	Total K = 420		



WAC 2013		Form B
Pilot ID	Unlimited Programme Free	Flight #



Power			
Fig 1	5.2.1.1	17	47
	9.10.6.4	19	
	9.9.5.4	11	
Fig 2	1.2.7.1	13	53
	9.4.1.4	15	
	9.10.4.2	13	
Fig 3	6.2.1.1	15	34
	9.2.1.4	13	
	9.1.5.3	6	
Fig 4	1.3.11.1	20	56
	9.4.1.3	12	
	9.9.9.4	13	
	9.1.4.2	4	
	9.8.1.1	7	
Fig 5	1.3.11.4	20	59
	9.12.1.4	7	
	9.1.5.1	2	
	9.4.2.2	7	
	9.1.2.8	15	
Fig 6	8.4.3.1	15	42
	9.1.1.5	14	
	9.9.10.3	13	
Fig 7	7.2.1.1	6	45
	9.2.3.8	15	
	9.1.3.6	10	
	9.9.3.6	14	
Fig 8	2.2.5.4	25	25
Fig 9	1.3.9.2	24	59
	9.1.1.1	6	
	9.9.4.8	17	
	9.1.1.4	12	
Total K = 420			

Patrick PARIS Pilot
 Cap 232 NX232X A/C



WAC 2013		Form B
Pilot ID	Unlimited Programme Free	Flight #

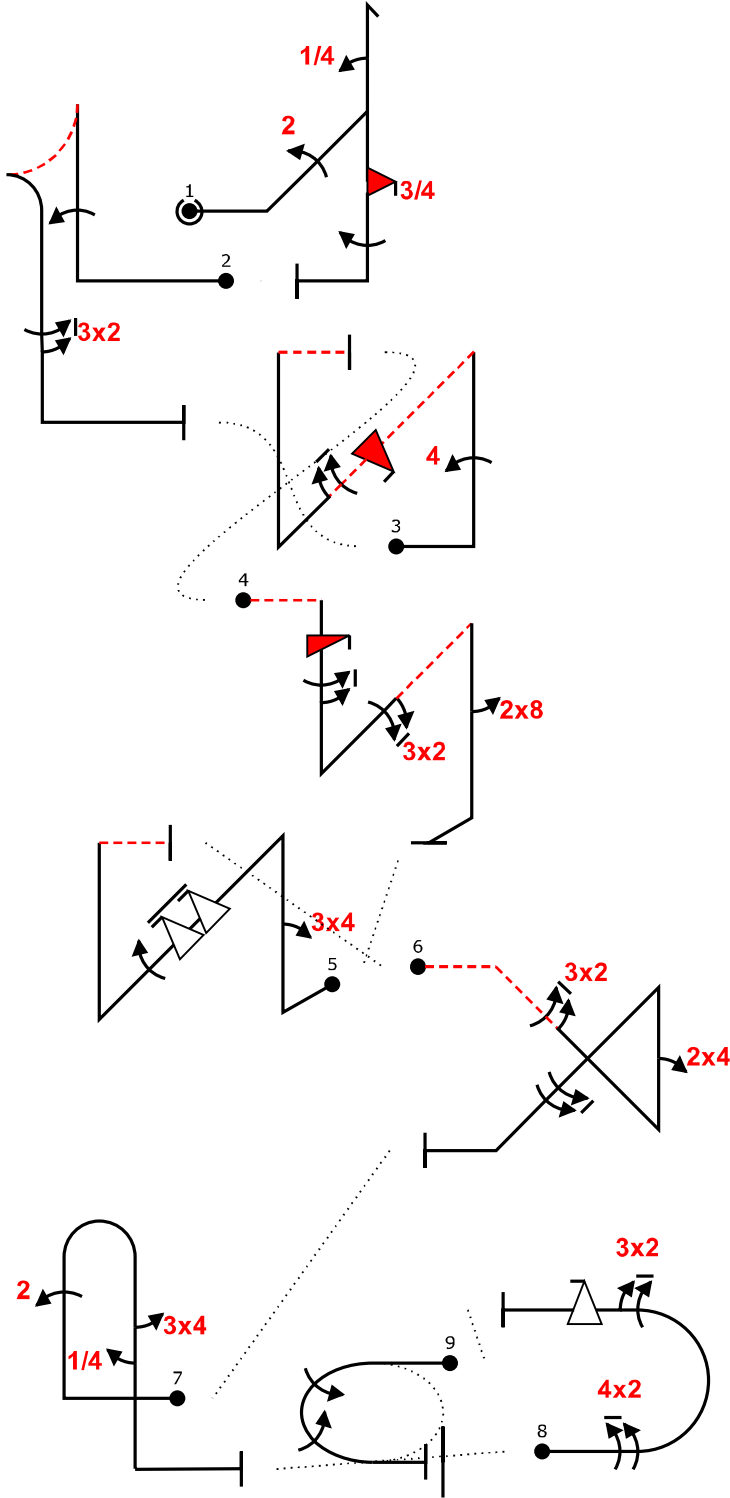
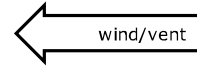

Power			
Fig 1	5.3.1.1	18	56
	9.2.2.4	11	
	9.1.1.1	6	
	9.10.5.3	13	
	9.1.5.4	8	
Fig 2	6.2.2.1	15	39
	9.1.1.4	12	
	9.2.5.6	12	
Fig 3	1.3.11.1	20	58
	9.4.1.4	15	
	9.10.4.4	13	
	9.1.4.6	10	
Fig 4	1.3.11.4	20	54
	9.12.1.4	7	
	9.1.5.6	10	
	9.2.2.6	14	
	9.8.5.1	3	
Fig 5	1.3.14.1	22	59
	9.4.1.3	12	
	9.9.4.8	17	
	9.1.4.4	8	
Fig 6	1.3.6.4	19	52
	9.2.4.6	12	
	9.4.1.2	9	
	9.1.4.8	12	
Fig 7	8.4.1.1	13	36
	9.2.1.4	13	
	9.4.5.3	8	
	9.1.5.1	2	
Fig 8	7.2.2.1	6	44
	9.2.3.8	15	
	9.2.3.6	12	
	9.9.3.4	11	
Fig 9	2.2.5.1	22	22
Total K = 420			

Yoshinide Muroya
 Pilot
 Edge540 N19ZE
 A/C

Pilot ID #

Unlimited Free

Flight #

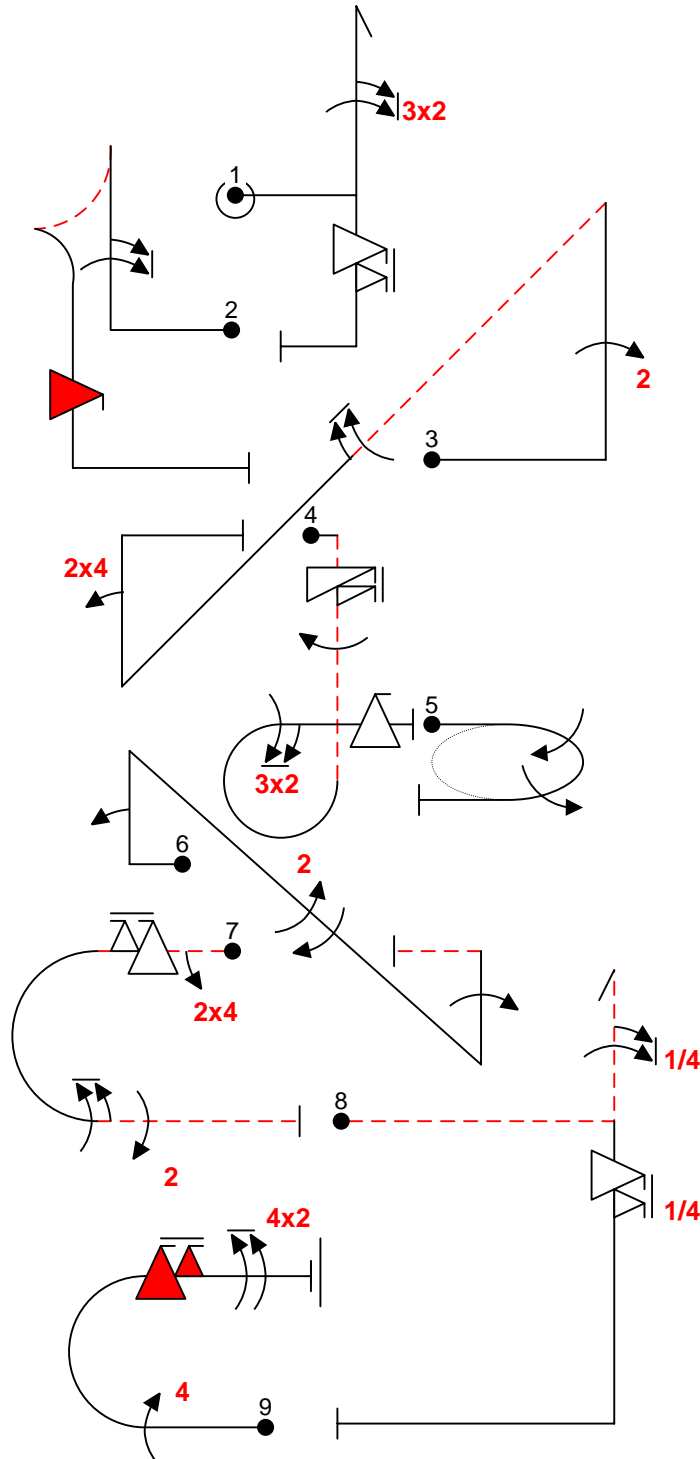
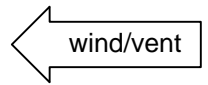

Fig 1	5.2.1.1 9.2.1.6 9.9.5.6	17 17 14	48
Fig 2	6.2.2.1 9.1.1.6 9.10.5.4	15 15 13	43
Fig 3	1.3.12.1 9.2.1.4 9.1.4.6 9.4.1.2	21 13 10 9	53
Fig 4	8.6.4.3 9.1.1.6 9.1.5.4 9.2.3.6 9.9.3.4	13 3 8 12 11	47
Fig 5	2.2.6.1	25	25
Fig 6	1.3.14.1 9.1.1.2 9.2.4.4 9.1.4.4 9.1.1.4	22 8 9 8 12	59
Fig 7	7.2.2.4 9.4.3.2 9.9.3.6 9.1.3.6 9.2.3.4	7 5 14 10 9	45
Fig 8	5.2.1.4 9.1.1.5 9.9.5.5	22 14 13	49
Fig 9	7.2.2.1 9.4.3.4 9.10.8.6 9.2.3.8	6 11 19 15	51

Total K = 420

Pilot ID #

Unlimited Free

Flight #

wind/vent

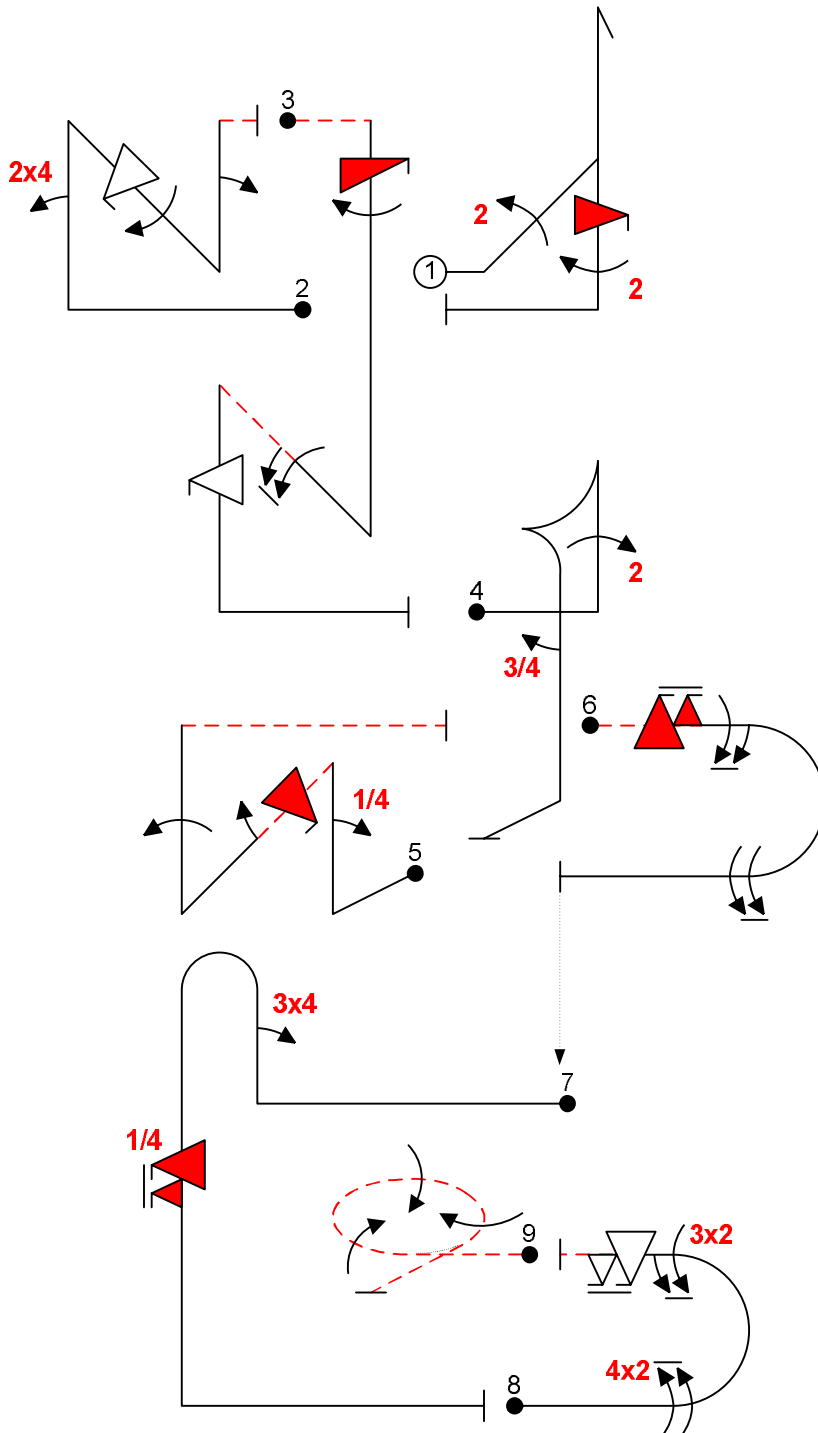
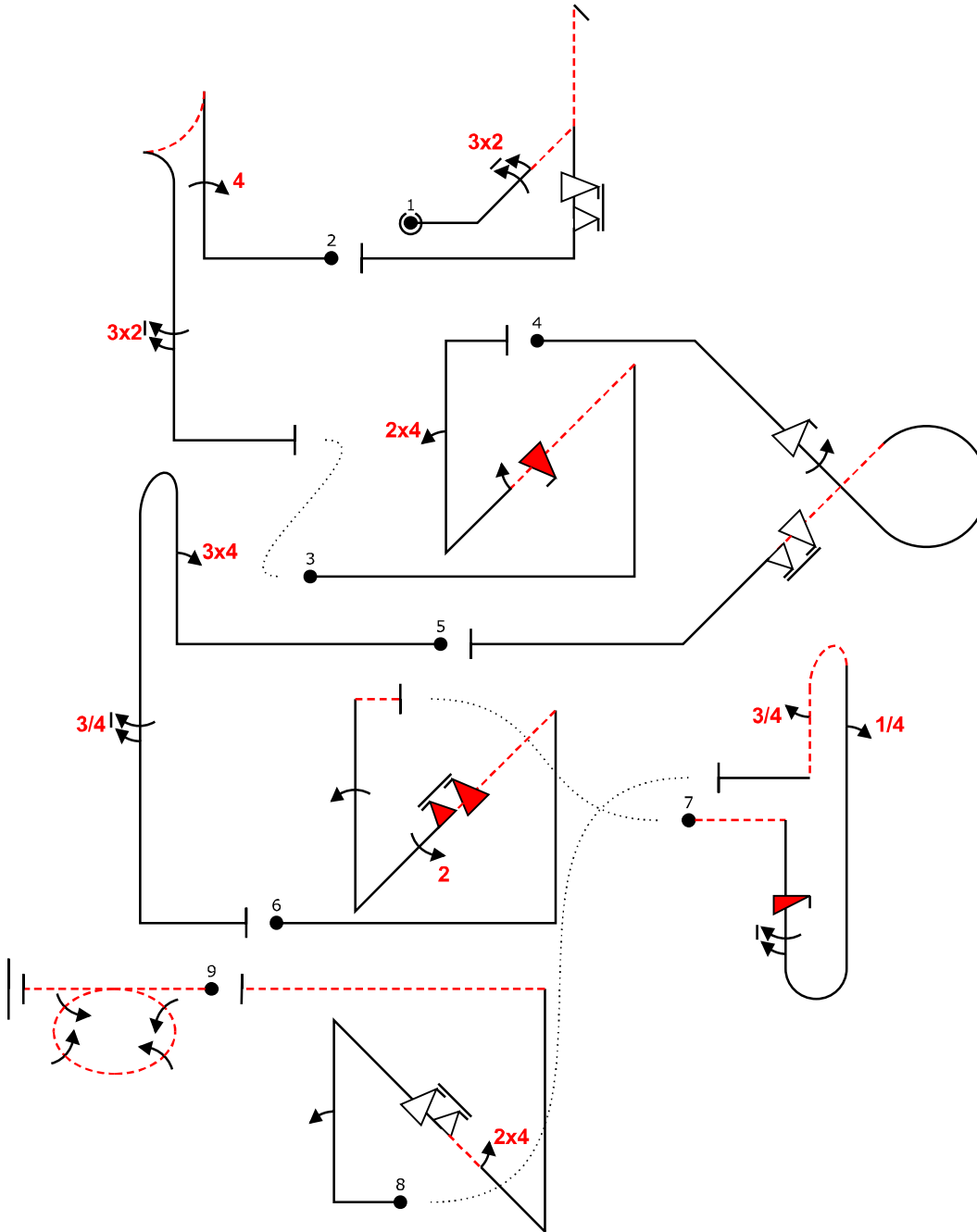
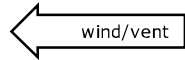

Fig 1	5.3.1.1 9.2.2.4 9.10.5.4 9.2.5.4	18 11 13 9	51
Fig 2	1.3.14.1 9.4.1.2 9.9.4.4 9.1.4.4 9.1.1.2	22 9 11 8 8	58
Fig 3	1.3.11.4 9.12.1.4 9.1.5.4 9.1.2.6 9.9.5.4	20 7 8 12 11	58
Fig 4	6.2.1.1 9.2.1.4 9.1.5.3	15 13 6	34
Fig 5	1.3.11.1 9.1.1.1 9.10.4.4 9.1.4.2 9.1.1.4	20 6 13 4 12	55
Fig 6	7.2.1.4 9.10.3.6 9.1.3.6 9.1.3.8	6 16 10 12	44
Fig 7	8.4.1.1 9.4.1.3 9.10.10.5	13 12 17	42
Fig 8	7.2.1.1 9.2.3.8 9.2.3.6 9.9.3.6	6 15 12 14	47
Fig 9	2.3.4.2	31	31
Total K = 420			



WAC 2013		Form B
Pilot ID	Unlimited Programme Programme2	Flight #



Power			
Fig 1	5.3.2.1 9.2.2.6 9.9.5.6	24 14 14	52
Fig 2	6.2.2.1 9.4.1.4 9.2.5.6	15 15 12	42
Fig 3	1.3.12.1 9.10.4.4 9.1.4.2 9.4.1.2	21 13 4 9	47
Fig 4	7.3.3.3 9.9.4.4 9.1.4.4 9.9.9.6	14 11 8 16	49
Fig 5	8.4.1.1 9.4.1.3 9.1.5.7	13 12 11	36
Fig 6	1.3.11.1 9.10.4.6 9.2.4.4 9.1.1.4	20 16 9 12	57
Fig 7	8.8.3.4 9.12.1.4 9.1.5.6 9.1.1.1 9.1.5.3	20 7 10 6 6	49
Fig 8	1.3.14.1 9.1.1.2 9.9.4.6 9.4.4.2	22 8 14 5	49
Fig 9	2.4.7.2	39	39
Total K = 420			

Artur Kielak Pilot
 XA-41, SP-EED A/C



WAC 2013		Form B
Pilot ID	Unlimited Programme Free	
		Flight #

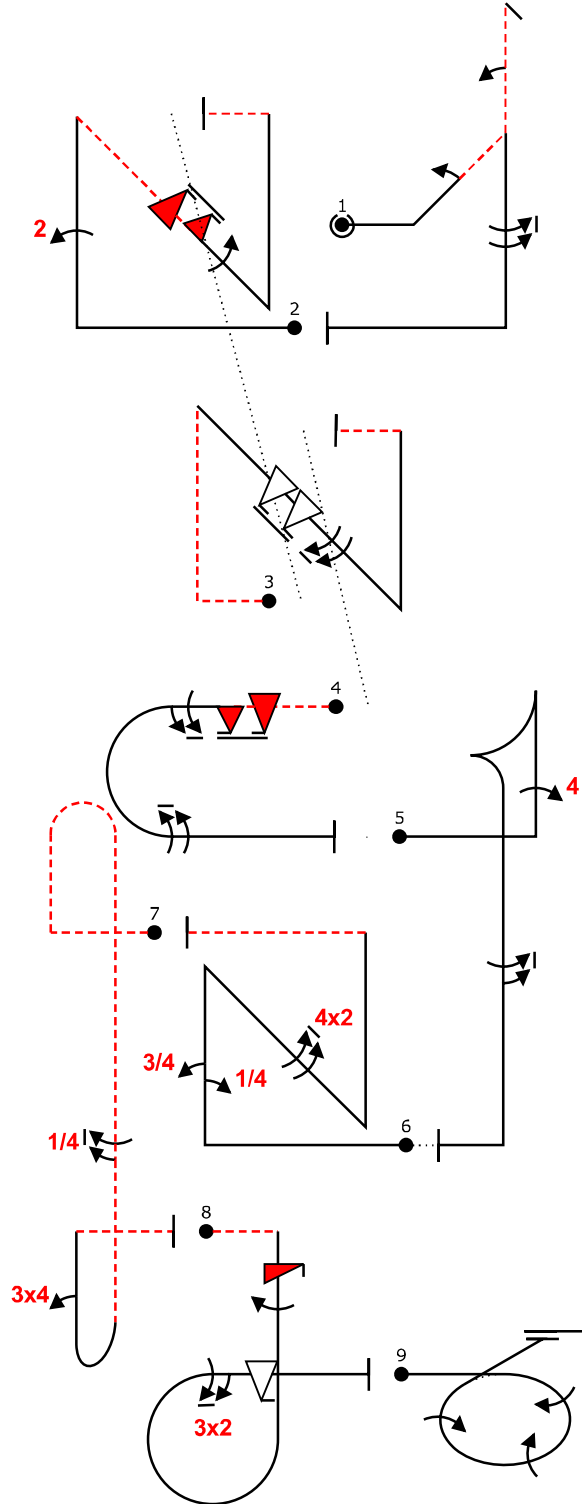
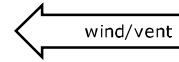

Power			
Fig 1	5.3.2.1 9.1.2.2 9.1.1.2 9.1.5.8	24 6 8 12	50
Fig 2	1.3.11.1 9.2.1.4 9.10.4.6 9.1.4.4	20 13 16 8	57
Fig 3	1.3.9.2 9.9.4.8 9.1.4.8	24 17 12	53
Fig 4	7.2.1.4 9.10.3.6 9.1.3.6 9.1.3.8	6 16 10 12	44
Fig 5	6.2.1.1 9.4.1.4 9.1.5.6	15 15 10	40
Fig 6	1.3.14.1 9.1.1.1 9.1.1.3 9.2.4.8	22 6 10 15	53
Fig 7	8.8.4.2 9.1.5.5 9.4.1.3	22 9 12	43
Fig 8	8.6.2.4 9.12.1.4 9.1.5.4 9.2.3.6 9.9.3.4	12 7 8 12 11	50
Fig 9	2.3.4.1	30	30
Total K = 420			

Nigel Hopkins Pilot
 MXS N540JH A/C

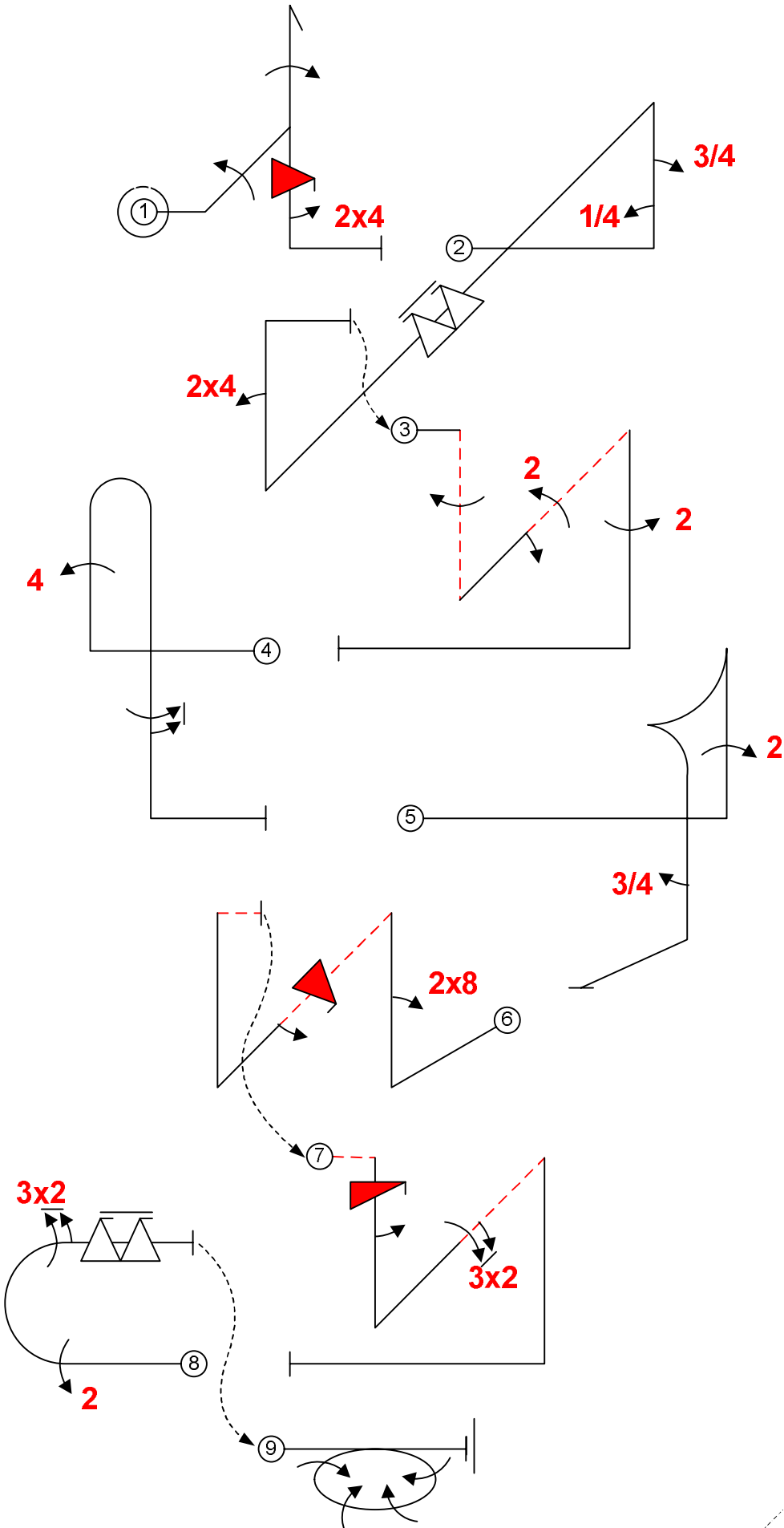

Fig 1	5.3.1.1	18	58
	9.1.2.4	10	
	9.1.1.4	12	
	9.10.5.4	13	
	9.4.5.2	5	
Fig 2	1.3.13.1	22	64
	9.1.1.1	6	
	9.1.1.3	10	
	9.9.4.8	17	
	9.4.1.2	9	
Fig 3	1.3.16.3	21	55
	9.1.5.4	8	
	9.1.2.2	6	
	9.2.2.4	11	
	9.2.5.4	9	
Fig 4	8.4.1.1	13	38
	9.4.1.4	15	
	9.1.5.6	10	
Fig 5	6.2.1.1	15	34
	9.2.1.4	13	
	9.1.5.3	6	
Fig 6	1.3.11.1	20	44
	9.8.1.1	7	
	9.10.4.4	13	
	9.1.4.2	4	
Fig 7	1.3.11.4	20	45
	9.12.1.4	7	
	9.1.5.2	4	
	9.2.2.6	14	
Fig 8	7.2.2.1	6	44
	9.9.3.8	17	
	9.2.3.4	9	
	9.2.3.6	12	
Fig 9	2.4.7.1	38	38
Total K = 420			

Anton Berkutov, Russia
Sukhoi pilot
A/C

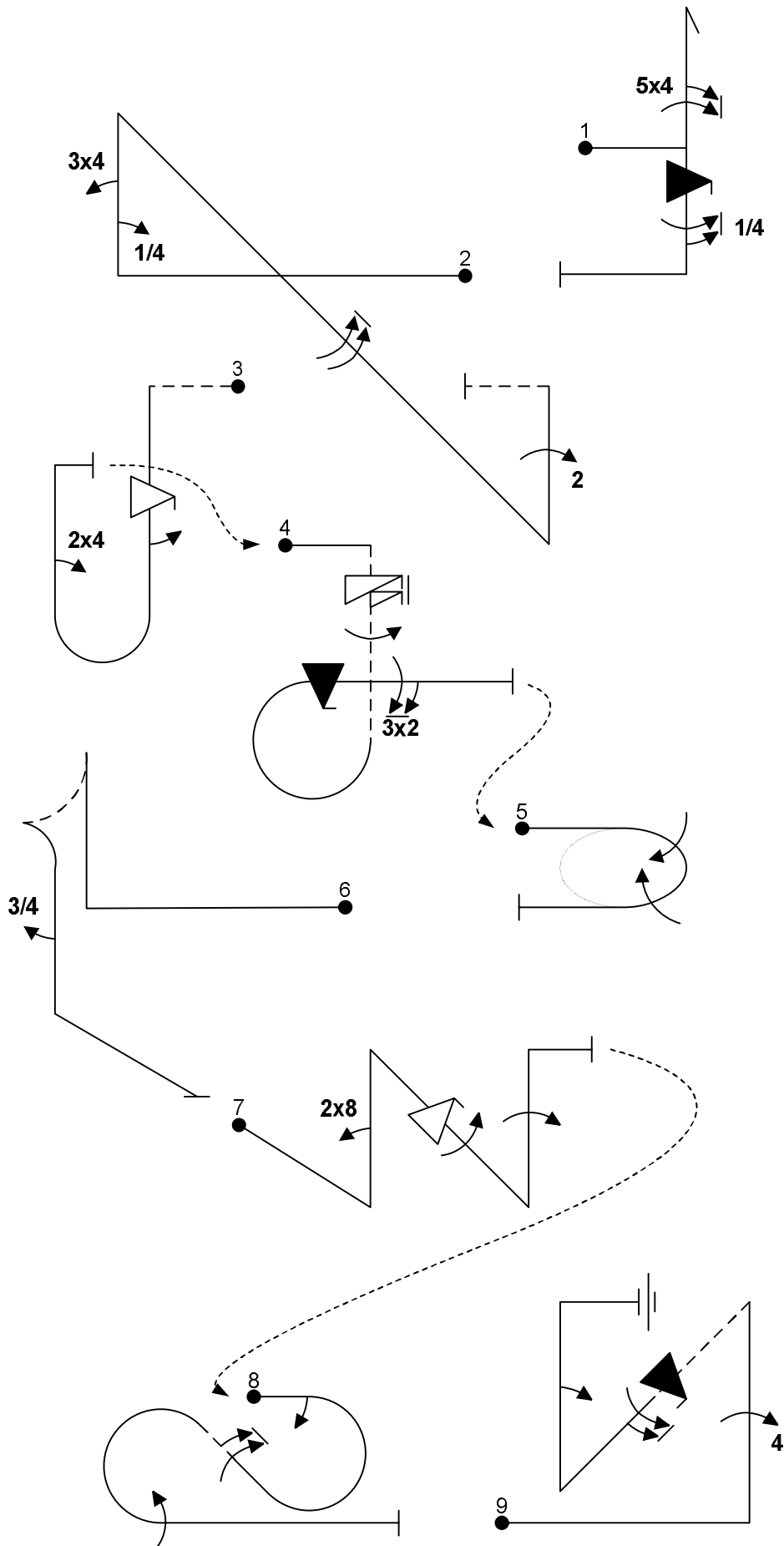

Fig 1	5.2.1.1 9.10.5.4 9.1.5.5 9.4.1.5	17 13 9 18		57
Fig 2	1.3.14.1 9.1.1.1 9.1.4.8 9.2.1.4 9.4.1.3	22 6 12 13 12		65
Fig 3	8.4.2.4 9.4.1.2 9.9.5.4 9.1.5.2	14 9 11 4		38
Fig 4	8.6.4.3 9.11.1.6 9.1.5.4 9.10.8.4 9.2.3.6	13 3 8 15 12		51
Fig 5	2.2.5.1	22		22
Fig 6	6.2.2.1 9.1.5.3	15 6		21
Fig 7	1.3.13.1 9.8.1.1 9.9.4.4 9.1.1.4 9.1.4.4	22 7 11 12 8		60
Fig 8	7.8.2.3 9.1.2.6 9.1.3.2 9.1.3.4	15 12 4 8		39
Fig 9	1.3.12.1 9.4.1.4 9.10.4.4 9.1.4.6 9.1.1.2	21 15 13 10 8		67

Total K = 420

Pilot ID #

Unlimited Free

Flight #

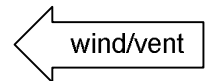
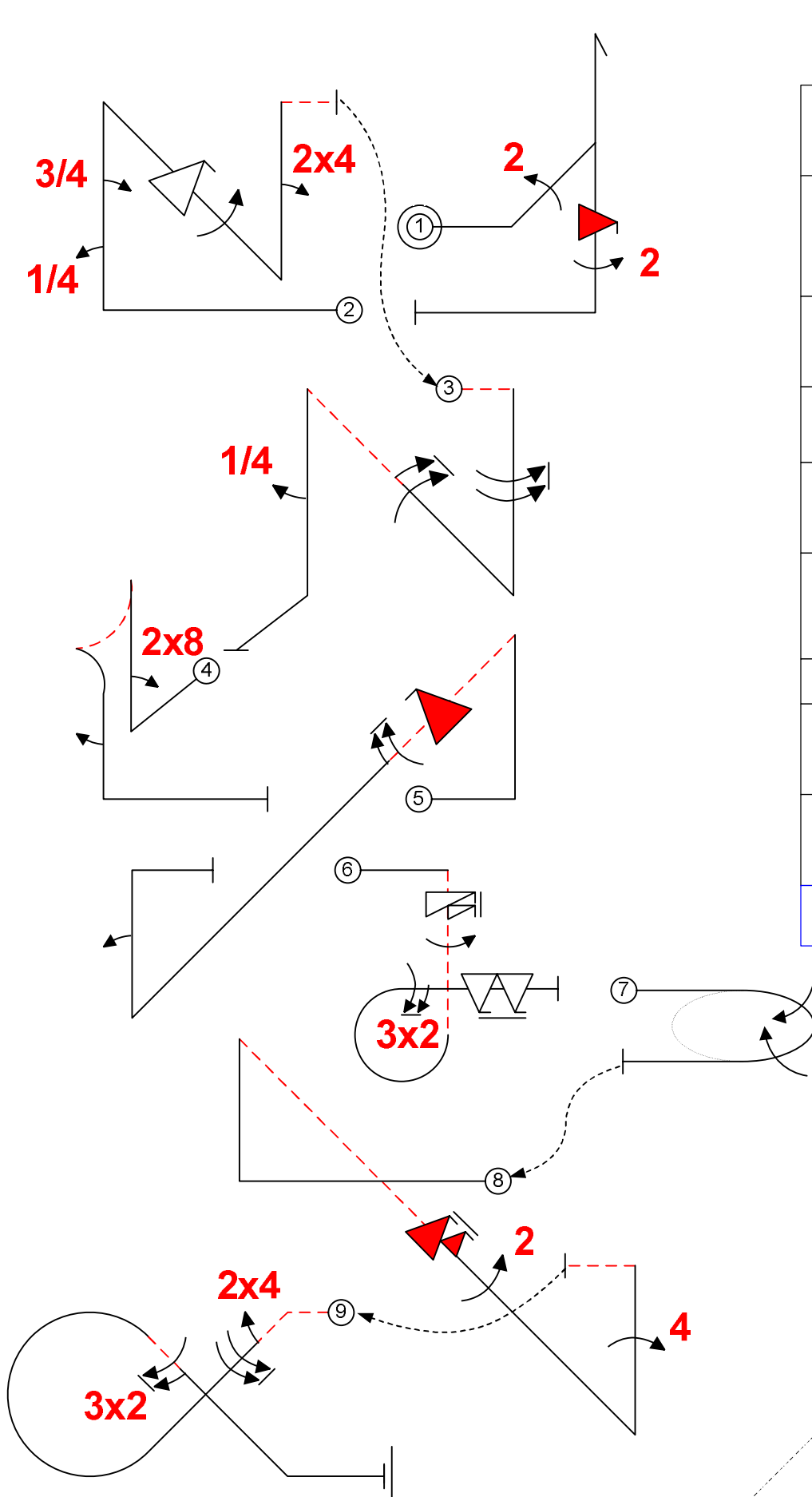
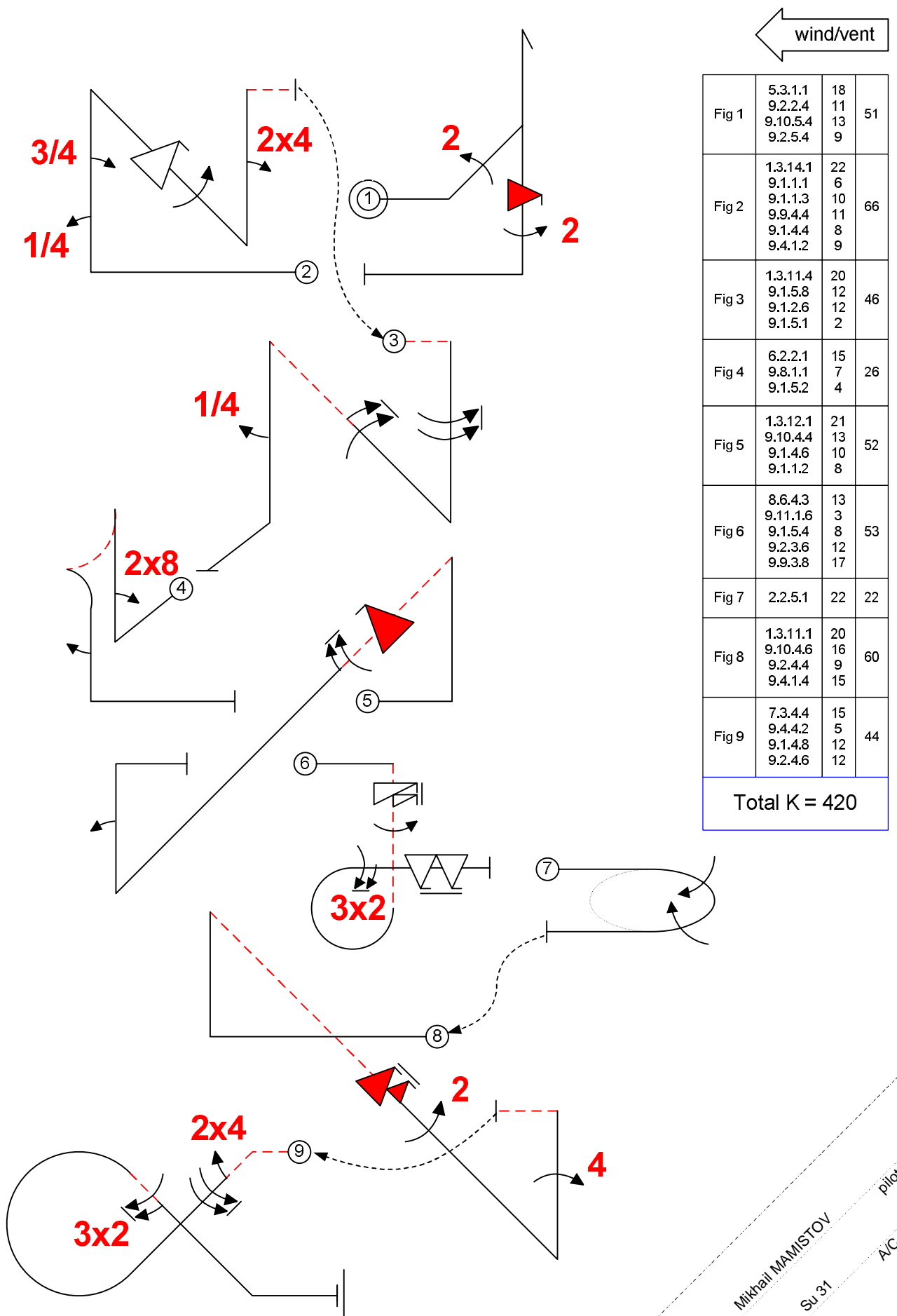

Fig 1	5.3.1.1 9.2.2.4 9.10.5.4 9.2.5.4	18 11 13 9	51
Fig 2	1.3.14.1 9.1.1.1 9.1.1.3 9.9.4.4 9.1.4.4 9.4.1.2	22 6 10 11 8 9	66
Fig 3	1.3.11.4 9.1.5.8 9.1.2.6 9.1.5.1	20 12 12 2	46
Fig 4	6.2.2.1 9.8.1.1 9.1.5.2	15 7 4	26
Fig 5	1.3.12.1 9.10.4.4 9.1.4.6 9.1.1.2	21 13 10 8	52
Fig 6	8.6.4.3 9.11.1.6 9.1.5.4 9.2.3.6 9.9.3.8	13 3 8 12 17	53
Fig 7	2.2.5.1	22	22
Fig 8	1.3.11.1 9.10.4.6 9.2.4.4 9.4.1.4	20 16 9 15	60
Fig 9	7.3.4.4 9.4.4.2 9.1.4.8 9.2.4.6	15 5 12 12	44
Total K = 420			

Pilot ID #

Unlimited Free

Flight #





Form B	
Pilot ID	Unlimited Programme Free
Flight #	

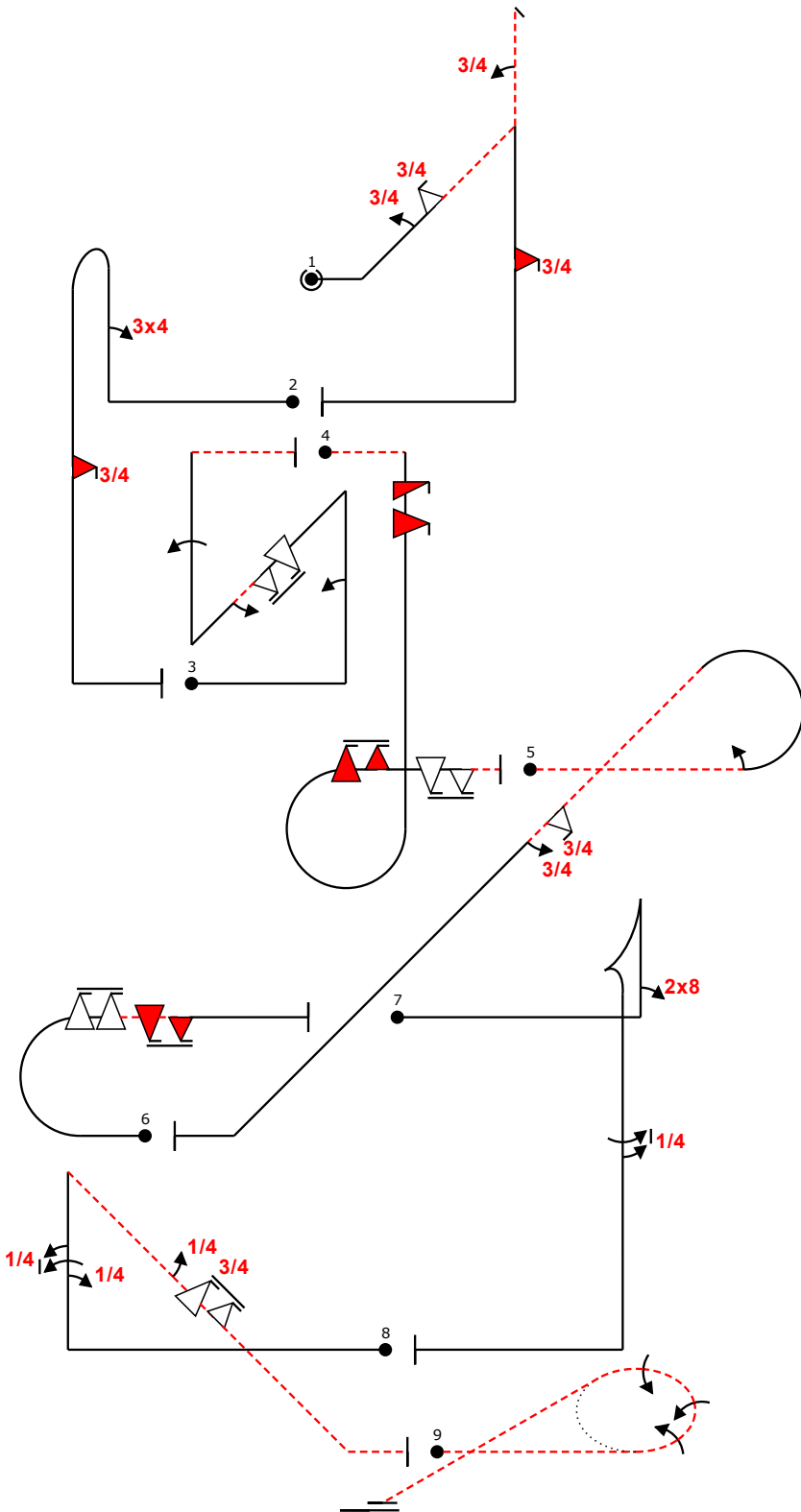
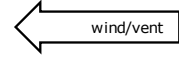

Power			
Fig 1	5.3.2.1	24	68
	9.1.2.3	8	
	9.9.2.3	13	
	9.1.1.3	10	
	9.10.5.3	13	
Fig 2	8.4.1.1	13	40
	9.4.1.3	12	
	9.10.10.3	15	
Fig 3	1.3.14.1	22	60
	9.1.1.2	8	
	9.9.4.6	14	
	9.1.4.2	4	
	9.1.1.4	12	
Fig 4	8.6.1.4	12	65
	9.12.1.4	7	
	9.10.5.4	13	
	9.10.8.6	19	
	9.9.3.6	14	
Fig 5	8.5.8.2	11	34
	9.1.3.2	4	
	9.9.9.3	13	
	9.1.4.3	6	
Fig 6	7.2.2.1	6	39
	9.9.3.8	17	
	9.10.3.6	16	
Fig 7	6.2.1.1	15	31
	9.8.1.1	7	
	9.1.5.5	9	
Fig 8	1.2.5.1	14	52
	9.1.1.1	6	
	9.1.1.5	14	
	9.1.4.1	2	
	9.9.4.7	16	
Fig 9	2.3.4.2	31	31
Total K = 420			

~+3;3f.dh(3)."3if..'+ + +',34"b..3if..' ++.2pn(` `6f;2)'1"-- ~-is;if...."irp6if",6f` ` ` ` -2c..
 ."3f;3.....' m9f,6if+~ 4> ~~+++,8ta"5..."++ ~~++++++',4,5'k"4;7f:- ~~-3j3-----

Ivanoff Pilot
 EDGE 54 A/C

Pilot ID #

Unlimited Free

Flight #

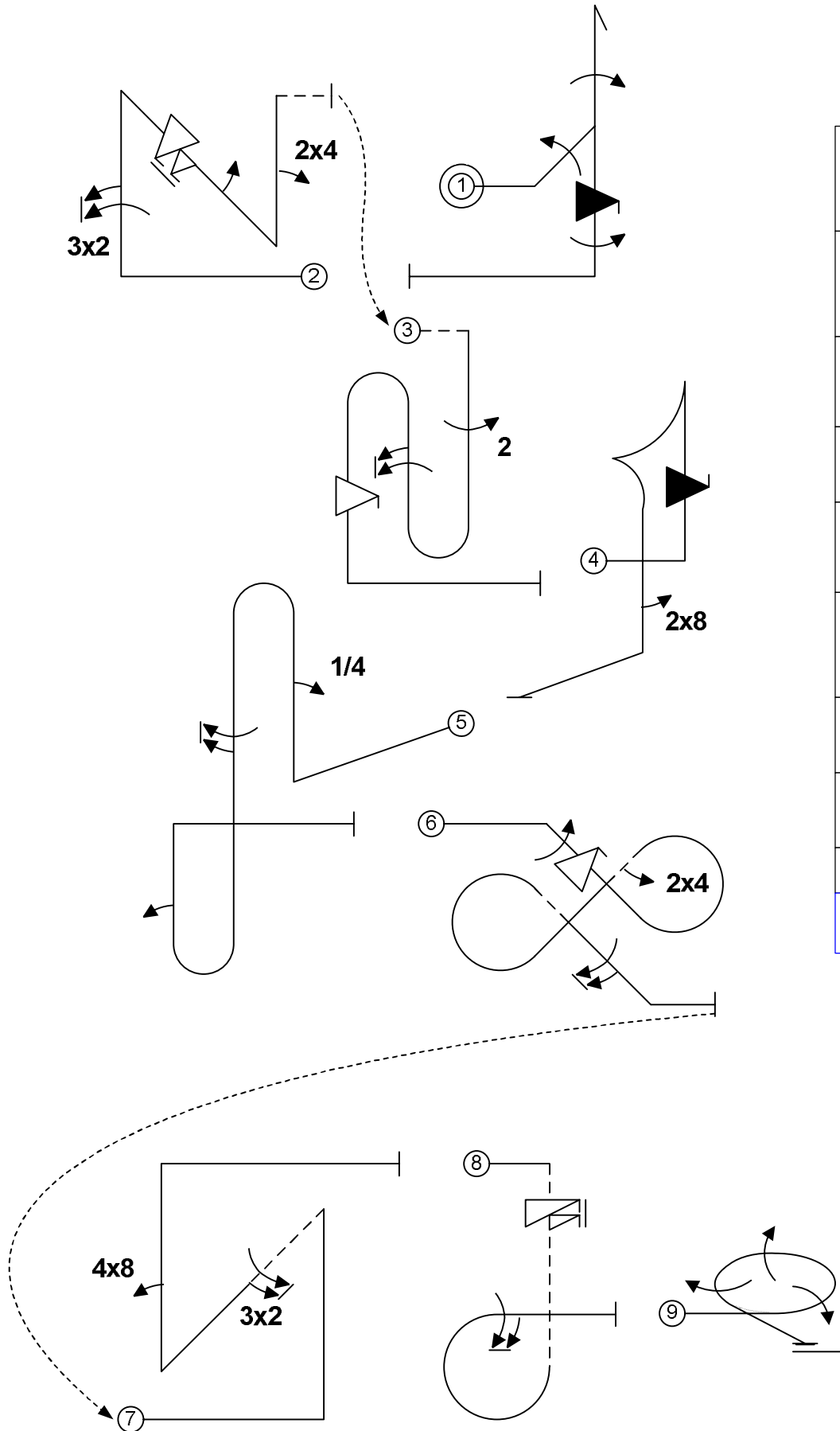
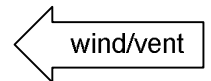
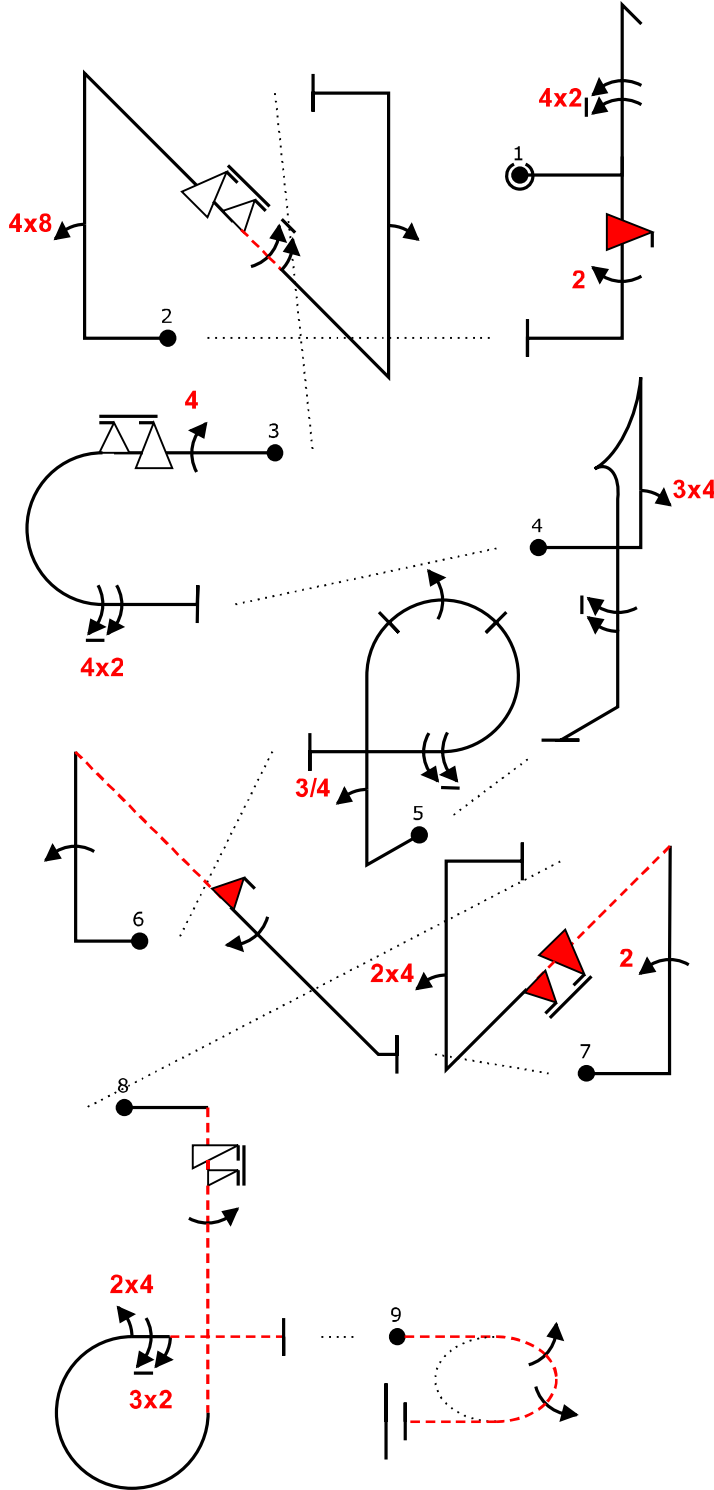
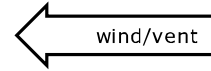

Fig 1	5.3.1.1 9.1.2.4 9.1.1.4 9.10.5.4 9.1.5.4	18 10 12 13 8	61
Fig 2	1.3.14.1 9.2.1.6 9.9.4.6 9.1.4.2 9.4.1.2	22 17 14 4 9	66
Fig 3	8.8.1.4 9.9.5.4 9.1.1.6 9.2.5.4	18 11 15 9	53
Fig 4	6.2.1.1 9.10.6.4 9.8.5.1	15 19 3	37
Fig 5	8.8.2.1 9.1.1.2 9.1.1.1 9.1.5.6	19 8 6 10	43
Fig 6	7.8.15.3 9.1.4.4 9.9.4.4 9.4.4.2 9.1.4.6	23 8 11 5 10	57
Fig 7	9.2.4.6 1.3.12.1 9.8.1.2	12 21 11	44
Fig 8	8.6.4.3 9.11.1.6 9.1.3.6	13 3 10	26
Fig 9	2.3.4.3	33	33
Total K = 420			



WAC 2013		Form B
Pilot ID	Unlimited Programme Free	
		Flight #



Power			
Fig 1	5.2.1.1 9.2.1.8 9.10.5.4 9.2.5.4	17 21 13 9	60
Fig 2	1.3.13.1 9.8.1.2 9.9.4.6 9.1.4.6 9.1.1.2	22 11 14 10 8	65
Fig 3	7.2.3.3 9.4.3.4 9.9.3.6 9.2.3.8	6 11 14 15	46
Fig 4	6.2.1.1 9.4.1.3 9.1.5.6	15 12 10	37
Fig 5	8.6.1.1 9.1.1.3 9.1.3.4 9.1.3.8	11 10 8 12	41
Fig 6	1.2.7.1 9.1.1.4 9.10.4.2 9.1.4.4	13 12 13 8	46
Fig 7	1.3.12.1 9.2.1.4 9.10.4.6 9.4.1.2	21 13 16 9	59
Fig 8	8.6.3.3 9.11.1.6 9.1.5.4 9.4.3.2 9.2.3.6	13 3 8 5 12	41
Fig 9	2.2.5.4	25	25
Total K = 420			

Hanspeter Rohrer
 Pilot
 Cap 232 N659DM
 A/C

Pilot ID #

Unlimited Free

Flight #

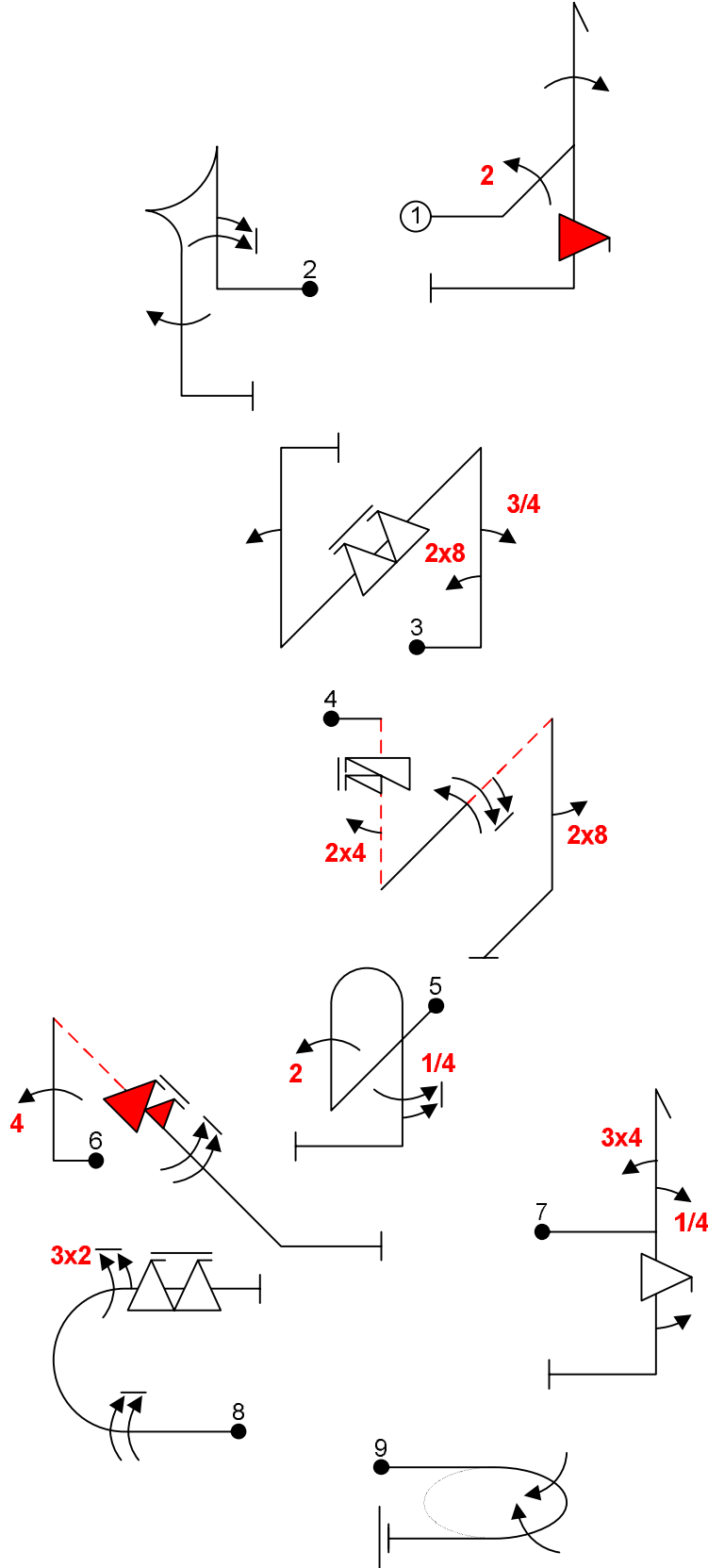
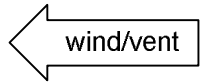

Fig 1	5.3.1.1 9.2.2.4 9.1.1.4 9.10.5.4	18 11 12 13	54
Fig 2	6.2.1.1 9.1.1.6 9.1.5.4	15 15 8	38
Fig 3	1.3.13.1 9.8.1.1 9.1.1.3 9.9.4.8 9.1.1.2	22 7 10 17 8	64
Fig 4	1.3.16.3 9.11.1.6 9.4.5.2 9.1.2.4 9.1.2.6 9.8.5.1	21 3 5 10 12 3	54
Fig 5	8.4.1.1 9.2.1.4 9.1.5.5	13 13 9	35
Fig 6	1.2.7.1 9.4.1.4 9.10.4.6 9.1.4.8	13 15 16 12	56
Fig 7	5.2.1.1 9.1.1.1 9.4.1.3 9.9.5.4 9.1.5.2	17 6 12 11 4	50
Fig 8	7.2.2.1 9.1.3.8 9.2.3.6 9.9.3.8	6 12 12 17	47
Fig 9	2.2.5.1	22	22

Total K = 420



Pilot ID		Form B
Unlimited Programme Free		Flight #

← wind/vent

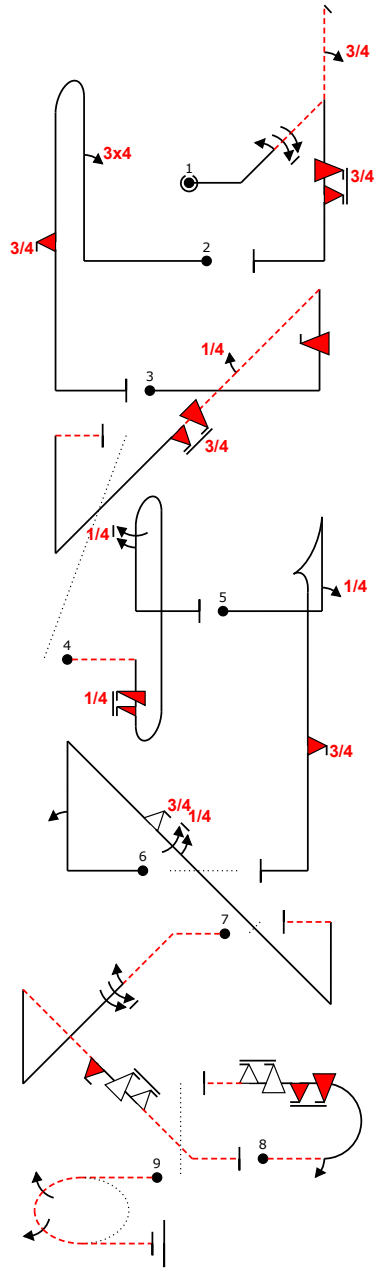

Power			
Fig 1	5.3.2.1	24	73
	9.1.2.2	6	
	9.1.2.8	15	
	9.1.1.3	10	
Fig 2	8.4.1.1	13	40
	9.4.1.3	12	
	9.10.10.3	15	
Fig 3	1.3.11.1	20	59
	9.10.6.4	19	
	9.1.4.1	2	
	9.10.4.7	18	
Fig 4	8.8.1.4	18	33
	9.12.1.5	6	
	9.1.5.5	9	
Fig 5	6.2.1.1	15	34
	9.1.1.1	6	
	9.10.5.3	13	
Fig 6 A	1.3.14.1	22	50
	9.1.1.2	8	
	9.9.4.3	11	
	9.1.4.5	9	
Fig 7	1.3.2.4	19	62
	9.1.4.2	4	
	9.1.4.8	12	
	9.10.4.2	13	
Fig 8	7.2.3.2	7	44
	9.1.3.2	4	
	9.10.8.6	19	
	9.9.3.6	14	
Fig 9	2.2.5.4	25	25
Total K = 420			

2,9dh(,3)"7if.~~ [0,0] ~+.,34.b.",3if.." ~+++if`n("4.,7if...)- [-7,19] -1% ``-`",5isibb(.
 ")` `5"> ,4ta."3if.." +` `` [-6,0] "@A" ~~2pn("3f;5....")` `` - [-1,1] -.,2,9iw',2if,6"" -2% --
 ` 2m6if 6f- f0.81 -2ia2-

leboulanger alexandre
 Pilot
 N4767
 A/C



Pilot ID		Form B
Unlimited Programme Free		Flight #

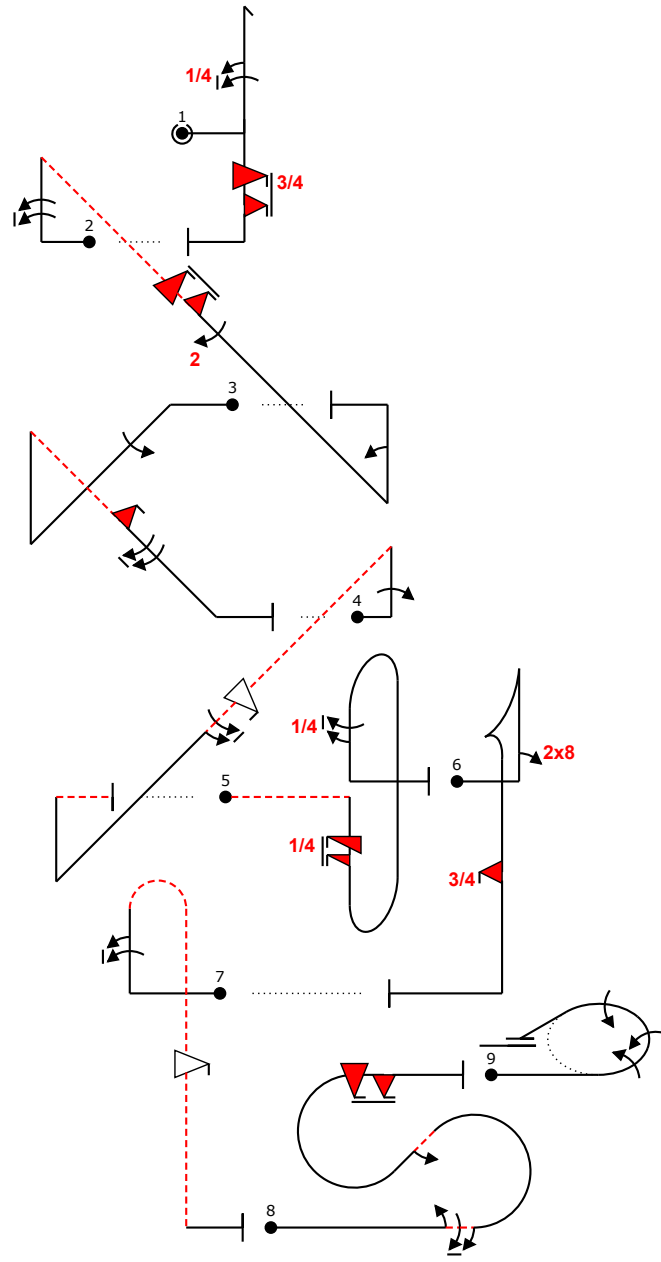
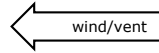

Olivier MASUREL
Pilot
A/C

Pilot ID #

Flight #

Unlimited Free

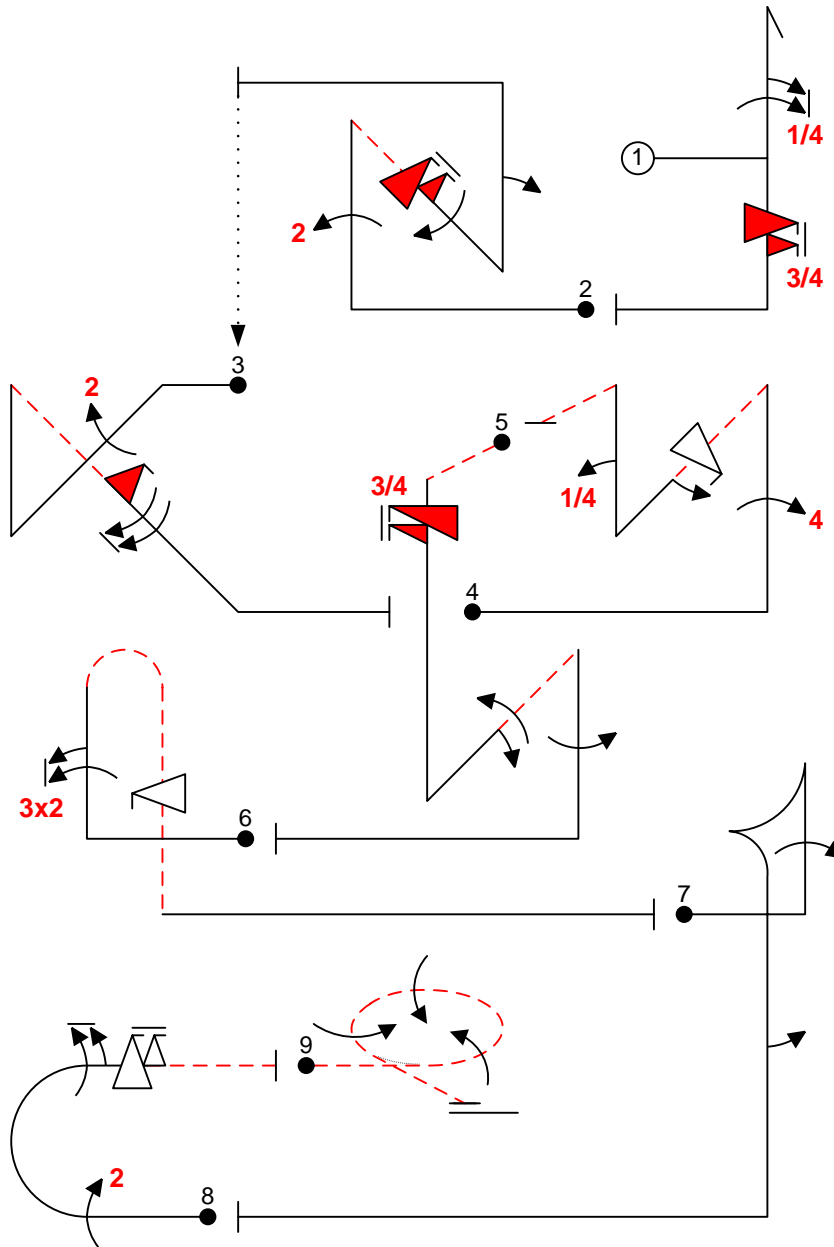
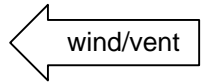

Fig 1	5.2.1.1 9.1.1.5 9.10.5.7	17 14 18	49
Fig 2	1.3.12.1 9.2.1.4 9.10.4.6 9.1.4.4 9.1.1.2	21 13 16 8 8	66
Fig 3	1.3.3.3 9.2.4.4 9.10.4.2 9.1.4.8	18 9 13 12	52
Fig 4	1.3.11.1 9.4.1.4 9.9.9.4 9.1.4.2 9.1.1.1	20 15 13 4 6	58
Fig 5	1.3.11.4 9.12.1.7 9.1.2.2 9.1.2.4 9.1.5.4	20 5 6 10 8	49
Fig 6	8.4.3.1 9.2.1.6 9.9.10.4	15 17 13	45
Fig 7	6.2.1.1 9.1.1.4 9.1.5.2	15 12 4	31
Fig 8	7.2.1.1 9.2.3.4 9.1.3.6 9.9.3.6	6 9 10 14	39
Fig 9	2.3.4.2	31	31
Total K = 420			

Pilot ID #

Unlimited Free

Flight #

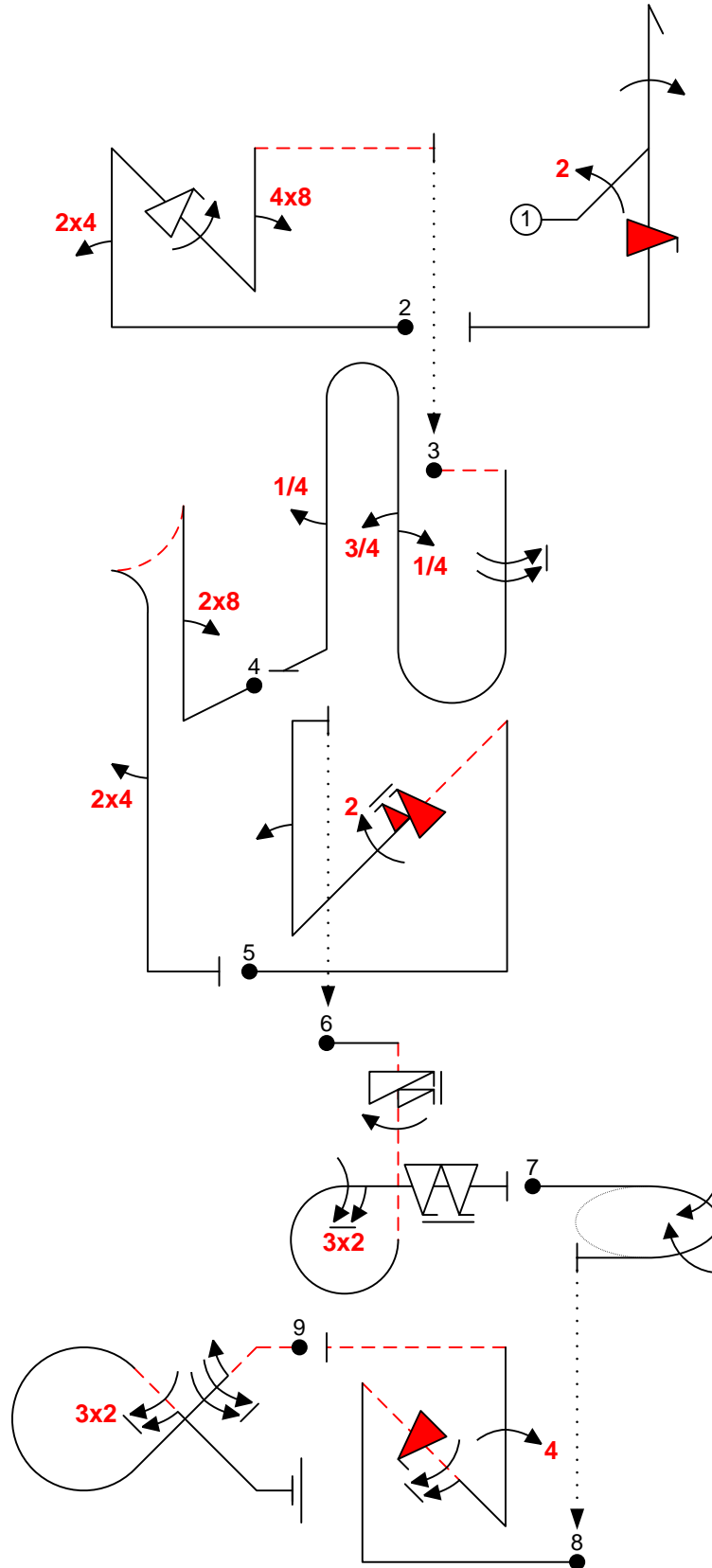
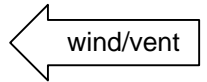

Fig 1	5.3.1.1	18	54
	9.2.2.4	11	
	9.1.1.4	12	
	9.10.5.4	13	
Fig 2	1.3.14.1	22	61
	9.4.1.2	9	
	9.9.4.4	11	
	9.1.4.4	8	
	9.8.1.2	11	
Fig 3	8.8.1.4	18	48
	9.1.5.8	12	
	9.1.1.1	6	
	9.1.1.3	10	
	9.1.5.1	2	
Fig 4	6.2.2.1	15	27
	9.8.1.1	7	
	9.4.5.2	5	
Fig 5	1.3.12.1	21	54
	9.10.4.6	16	
	9.2.4.4	9	
	9.1.1.2	8	
Fig 6	8.6.4.3	13	53
	9.11.1.6	3	
	9.1.5.4	8	
	9.2.3.6	12	
	9.9.3.8	17	
Fig 7	2.2.5.1	22	22
Fig 8	1.3.11.1	20	58
	9.10.4.4	13	
	9.1.4.6	10	
	9.4.1.4	15	
Fig 9	7.3.4.4	15	43
	9.1.4.2	4	
	9.1.4.8	12	
	9.2.4.6	12	

Total K = 420

Pilot ID #

Unlimited Free

Flight #

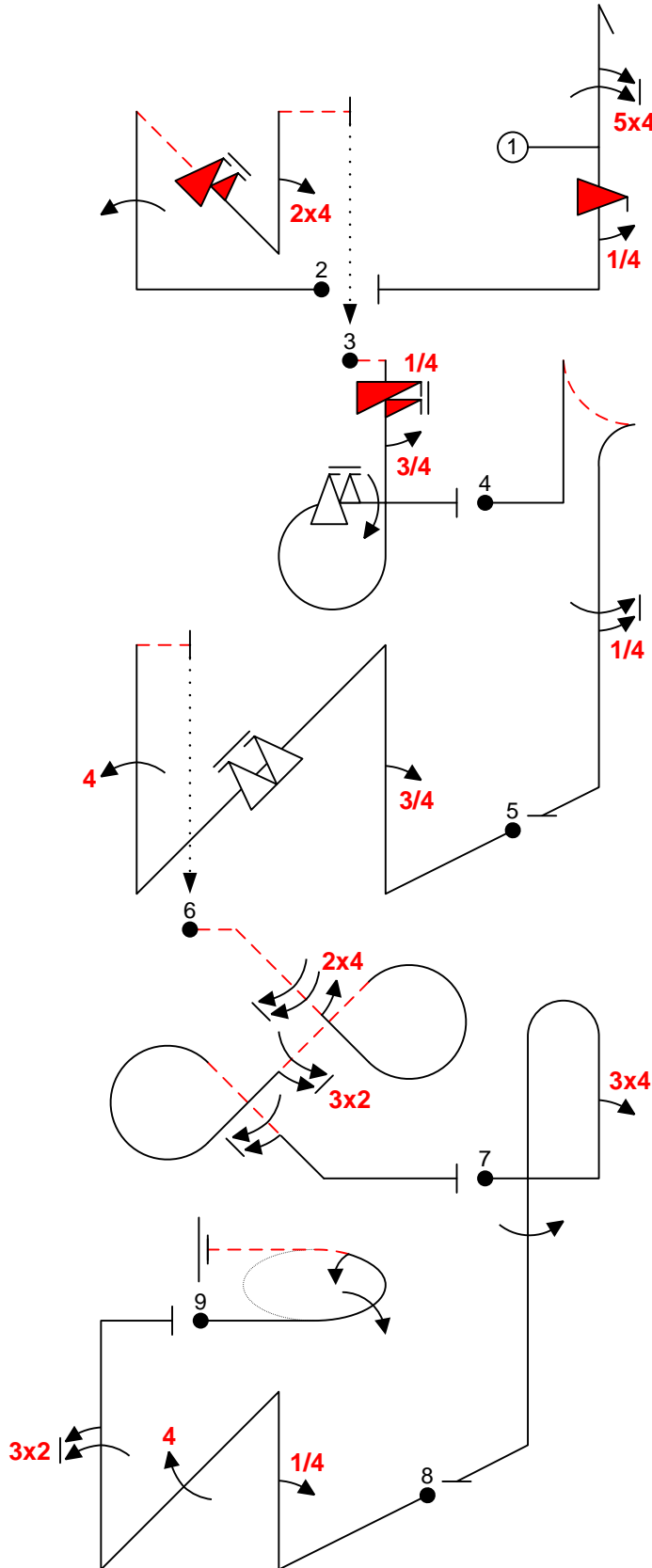
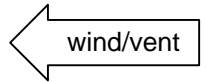

Fig 1	5.2.1.1 9.4.1.5 9.10.5.4 9.1.5.1	17 18 13 2	50
Fig 2	1.3.11.1 9.1.1.4 9.10.4.6 9.4.1.2	20 12 16 9	57
Fig 3	8.6.2.4 9.12.1.5 9.1.5.3 9.9.3.6 9.1.3.4	12 6 6 14 8	46
Fig 4	6.2.2.1 9.1.5.5	15 9	24
Fig 5	1.3.14.1 9.1.1.3 9.9.4.8 9.4.1.4	22 10 17 15	64
Fig 6	7.8.16.4 9.1.4.8 9.4.4.2 9.2.4.6 9.1.4.6	24 12 5 12 10	63
Fig 7	8.4.1.1 9.4.1.3 9.1.5.4	13 12 8	33
Fig 8	1.3.13.1 9.1.1.1 9.4.4.4 9.2.1.6	22 6 11 17	56
Fig 9	2.2.4.3	27	27
Total K = 420			

Pilot ID #

Unlimited Free

Flight #

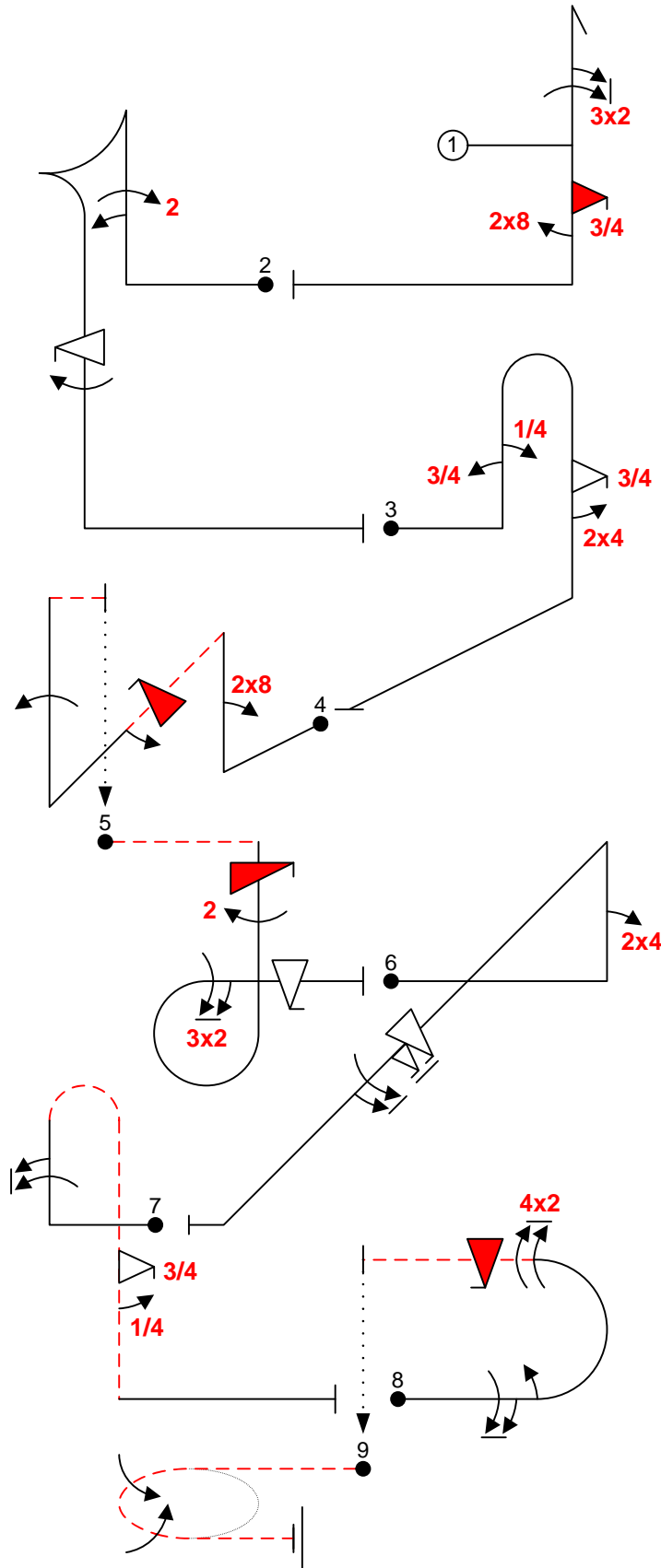
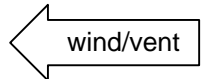

Fig 1	5.2.1.1 9.2.1.6 9.10.5.3 9.8.5.1	17 17 13 3	50
Fig 2	6.2.1.1 9.1.1.2 9.2.1.4 9.9.5.4 9.1.5.4	15 8 13 11 8	55
Fig 3	8.4.1.1 9.1.1.3 9.1.1.1 9.9.5.3 9.4.5.2	13 10 6 11 5	45
Fig 4	1.3.11.1 9.8.1.1 9.10.4.4 9.1.4.2 9.1.1.4	20 7 13 4 12	56
Fig 5	8.6.2.4 9.12.1.4 9.2.5.4 9.2.3.6 9.9.3.4	12 7 9 12 11	51
Fig 6	1.2.6.1 9.4.1.2 9.9.4.6 9.1.4.6	14 9 14 10	47
Fig 7	8.4.3.1 9.1.1.6 9.9.10.3 9.1.5.1	15 15 13 2	45
Fig 8	7.2.1.1 9.1.3.6 9.1.3.2 9.2.3.8 9.10.3.4	6 10 4 15 13	48
Fig 9	2.2.5.2	23	23
Total K = 420			

Pilot ID #

Unlimited Free

Flight #

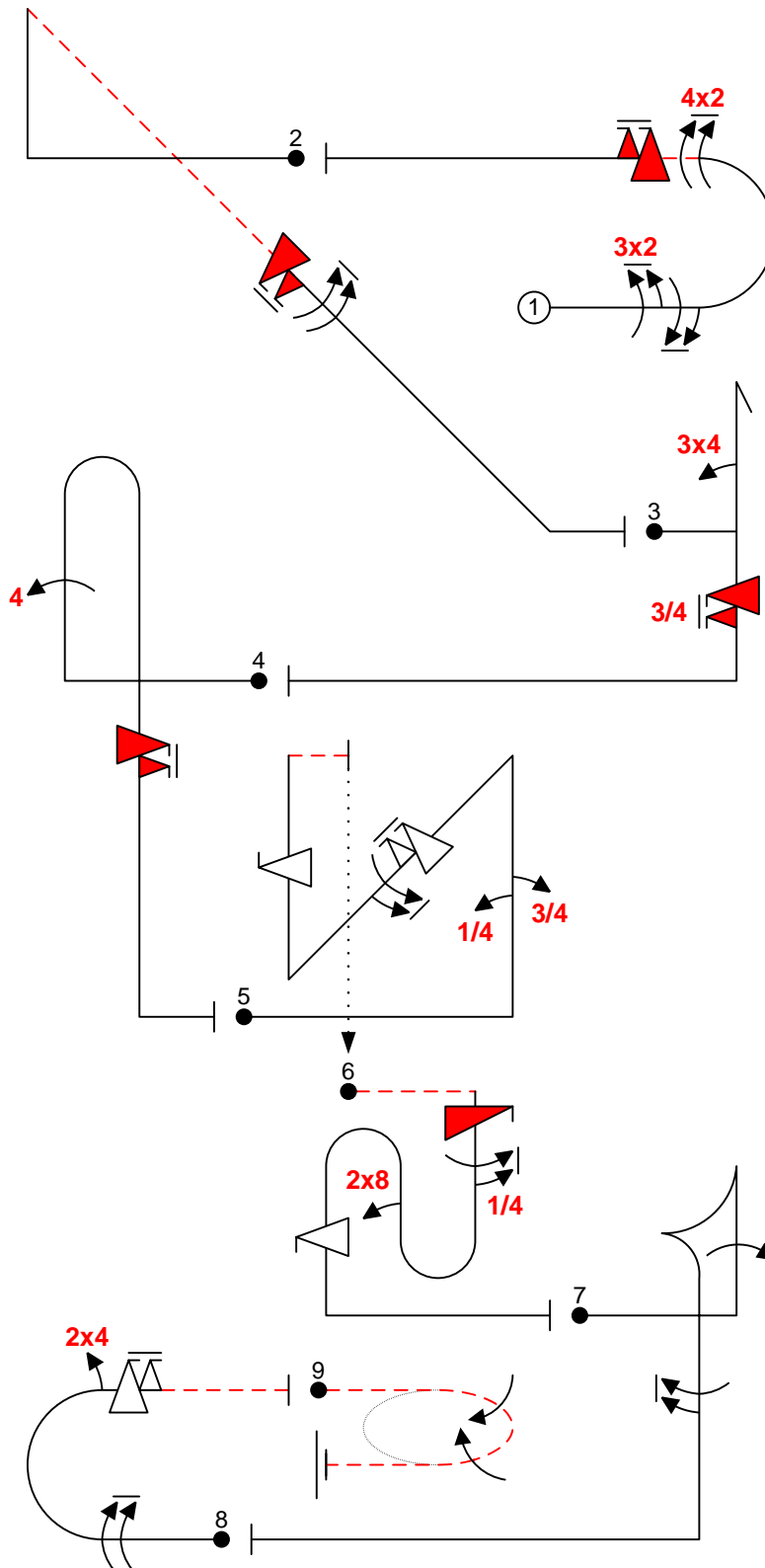
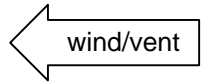

Fig 1	7.2.2.1	6	59
	9.2.3.6	12	
	9.1.3.6	10	
	9.2.3.8	15	
	9.10.3.6	16	
Fig 2	1.2.7.1	13	41
	9.10.4.6	16	
	9.1.4.8	12	
Fig 3	5.2.1.1	17	47
	9.4.1.3	12	
	9.10.5.7	18	
Fig 4	8.4.1.1	13	47
	9.4.1.4	15	
	9.10.10.6	19	
Fig 5	1.3.14.1	22	77
	9.1.1.1	6	
	9.1.1.3	10	
	9.9.4.6	14	
	9.1.4.6	10	
	9.9.1.4	15	
Fig 6	8.8.1.4	18	52
	9.12.1.4	7	
	9.1.5.5	9	
	9.8.1.1	7	
Fig 7	6.2.1.1	15	37
	9.1.1.4	12	
	9.1.5.6	10	
Fig 8	7.2.1.1	6	37
	9.1.3.8	12	
	9.4.3.2	5	
	9.9.3.6	14	
Fig 9	2.2.5.2	23	23
Total K = 420			

Pilot ID #

Unlimited Free

Flight #

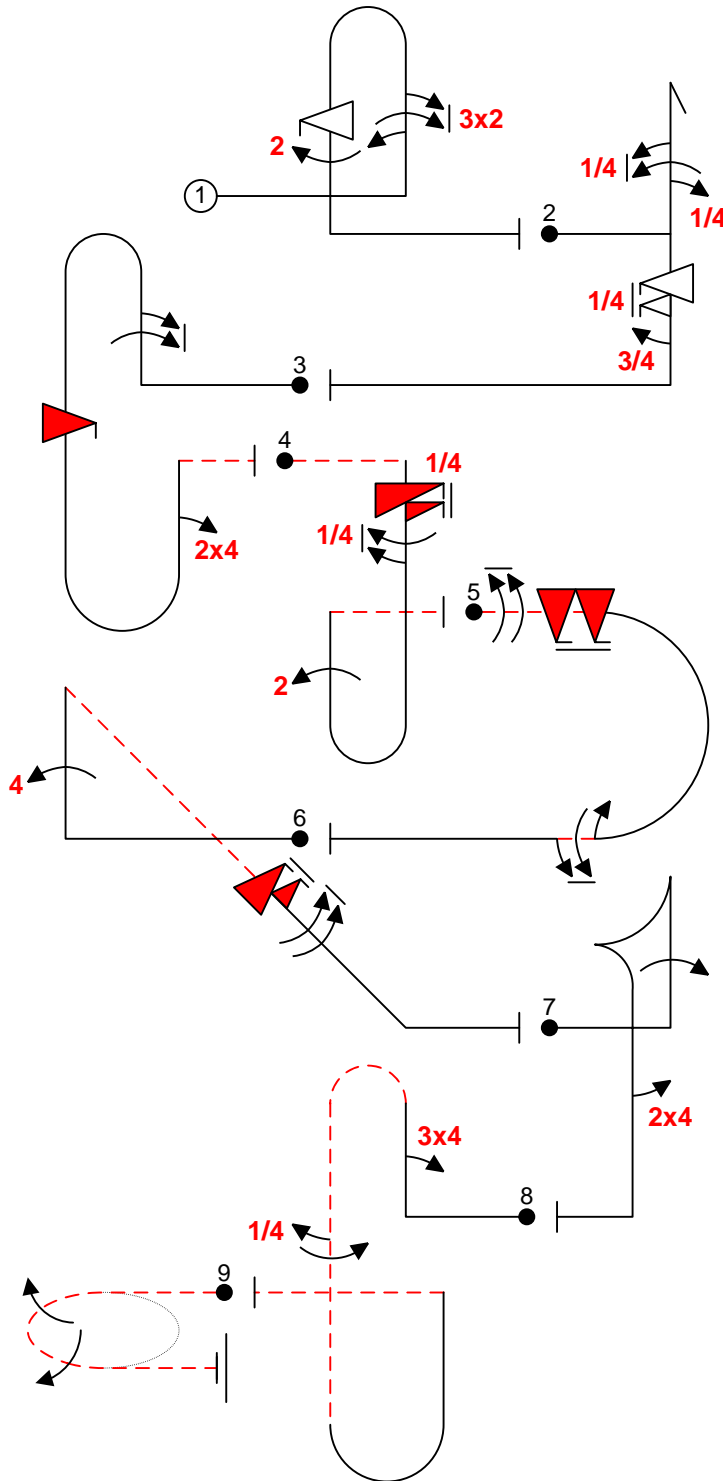
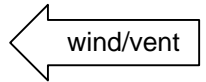
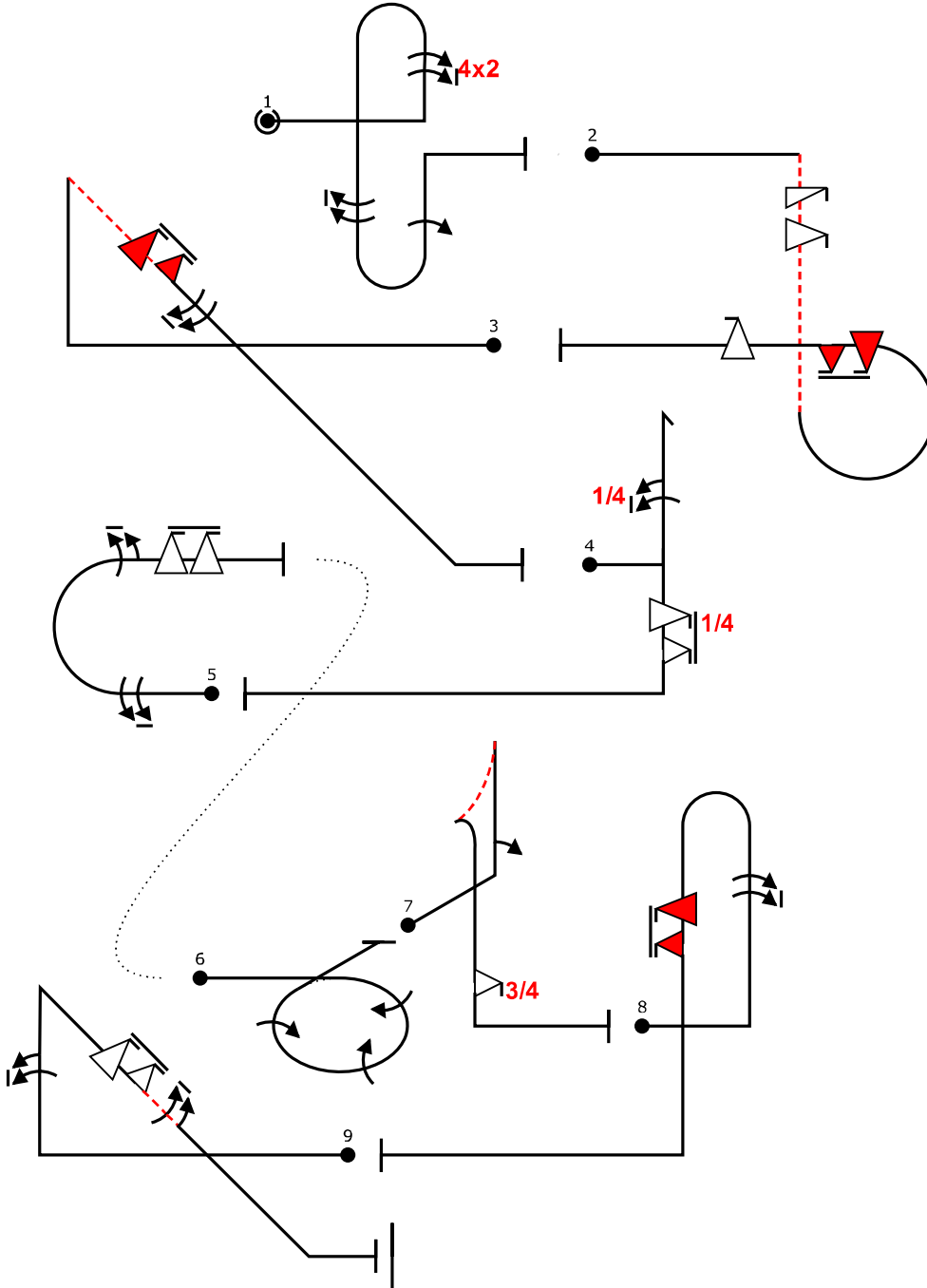
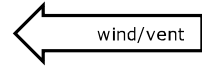

Fig 1	8.4.1.1	13	58
	9.1.1.2	8	
	9.2.1.6	17	
	9.9.5.4	11	
Fig 2	9.2.5.4	9	56
	5.2.1.1	17	
	9.1.1.1	6	
	9.1.1.5	14	
Fig 3	9.9.5.5	13	57
	9.1.5.3	6	
	8.8.1.1	18	
	9.1.1.6	15	
Fig 4	9.10.10.4	15	41
	9.4.1.2	9	
	8.4.1.4	13	
	9.12.1.5	6	
Fig 5	9.1.5.5	9	52
	9.2.1.4	13	
	7.2.1.4	6	
	9.1.3.8	12	
	9.10.3.8	20	
Fig 6	9.1.3.2	4	56
	9.1.3.6	10	
	1.2.7.1	13	
	9.4.1.4	15	
Fig 7	9.10.4.6	16	32
	9.1.4.8	12	
	6.2.1.1	15	
Fig 8	9.1.1.4	12	43
	9.4.5.2	5	
	8.8.5.1	21	
	9.4.1.3	12	
Fig 9	9.1.5.1	2	25
	9.1.5.4	8	
	2.2.5.4	25	

Total K = 420



WAC Oct. 2013		Form B
Pilot ID	Unlimited Programme Free	
		Flight #



Power			
Fig 1	8.8.2.1 9.2.1.8 9.1.5.8 9.1.1.4	19 21 12 12	64
Fig 2	8.6.4.3 9.11.1.4 9.9.5.4 9.10.8.6 9.9.3.4	13 5 11 19 11	59
Fig 3	1.2.7.1 9.10.4.6 9.1.4.8	13 16 12	41
Fig 4	5.2.1.1 9.1.1.5 9.9.5.5	17 14 13	44
Fig 5	7.2.2.1 9.1.3.8 9.1.3.6 9.9.3.8	6 12 10 17	45
Fig 6	2.3.4.1	30	30
Fig 7	6.2.2.1 9.1.1.2 9.9.5.3	15 8 11	34
Fig 8	8.4.1.1 9.1.1.8 9.10.10.6	13 18 19	50
Fig 9	1.2.6.1 9.1.1.6 9.9.4.6 9.1.4.6	14 15 14 10	53
Total K = 420			

Benjamin Freelye
 Edge 540RXP N540BF
 Pilot
 A/C