

FAI AEROBATICS COMMISSION

WAGAC 2018		Form B
Pilot ID	CIVA Glider Advanced FreeUnknown	A
		Flight #

← wind/vent

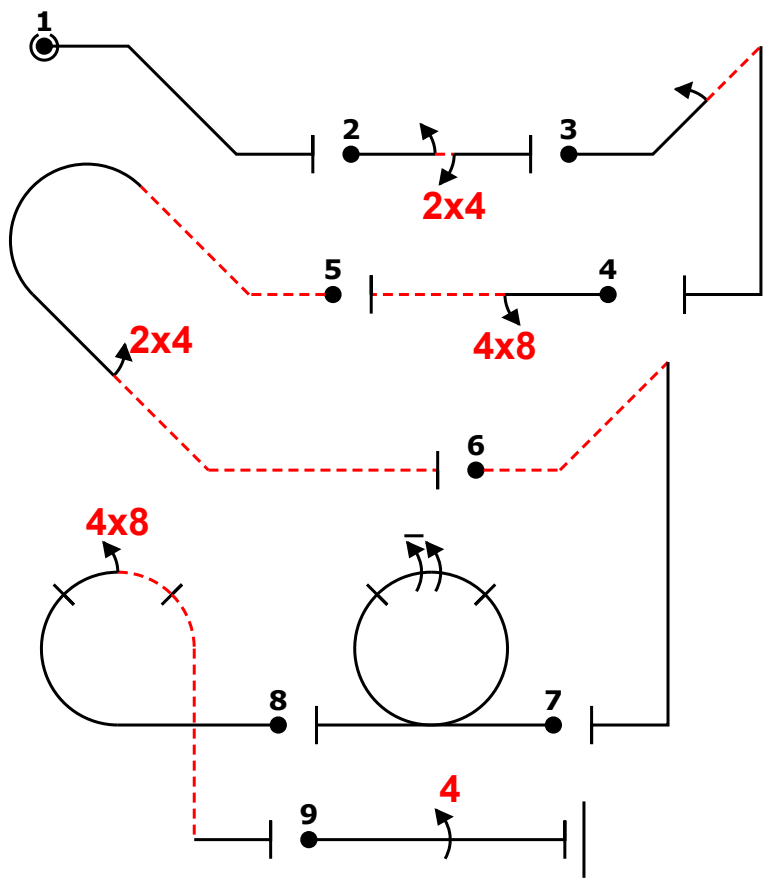

 Pilot
 A/C

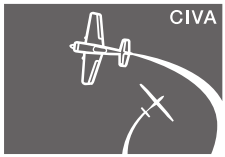

FAI

AEROBATICS
COMMISSION

Pilot ID

CIVA Glider Advanced FreeUnknown

B

Form B

Flight #

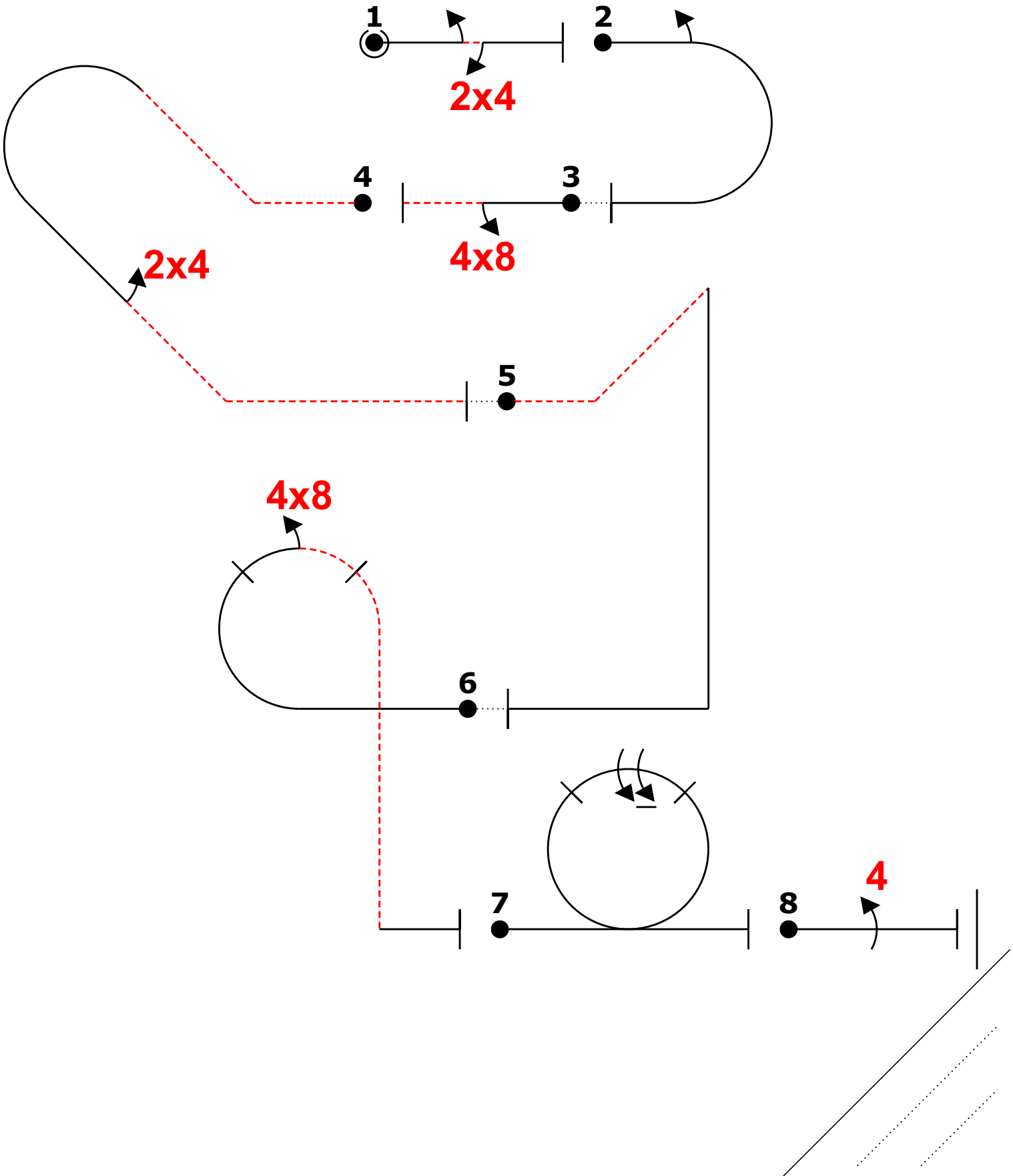

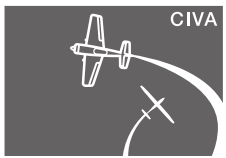

FAI AEROBATICS COMMISSION

		Form B
Pilot ID	CIVA Glider Advanced FreeUnknown	Flight #

C

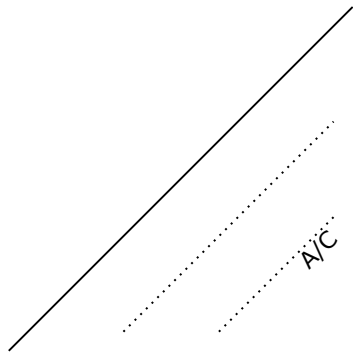
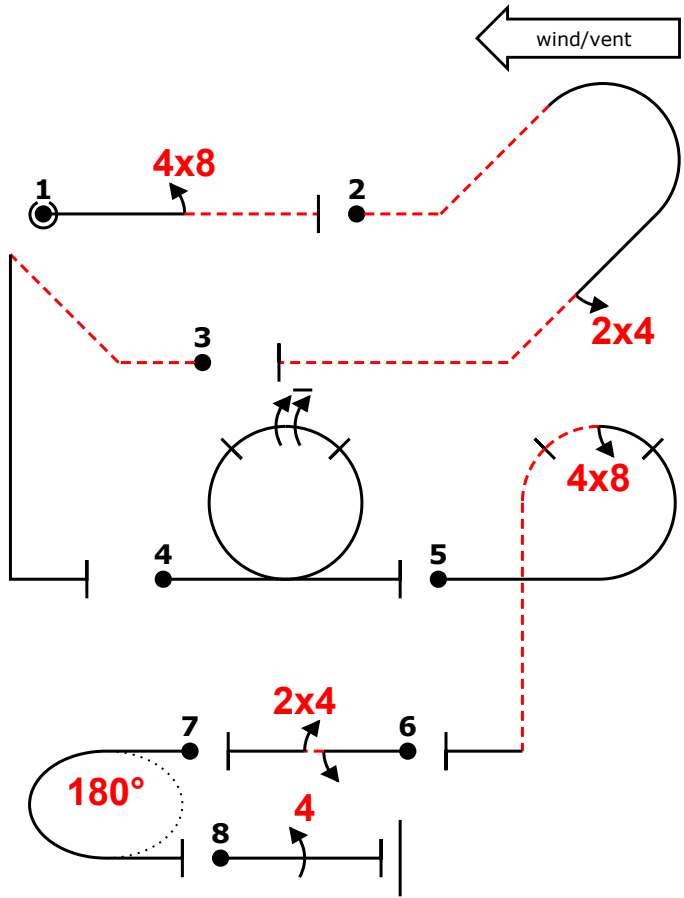



Zbraslavice 2018		Form B
Pilot ID	CIVA Glider Advanced FreeUnknown	D
		Flight #

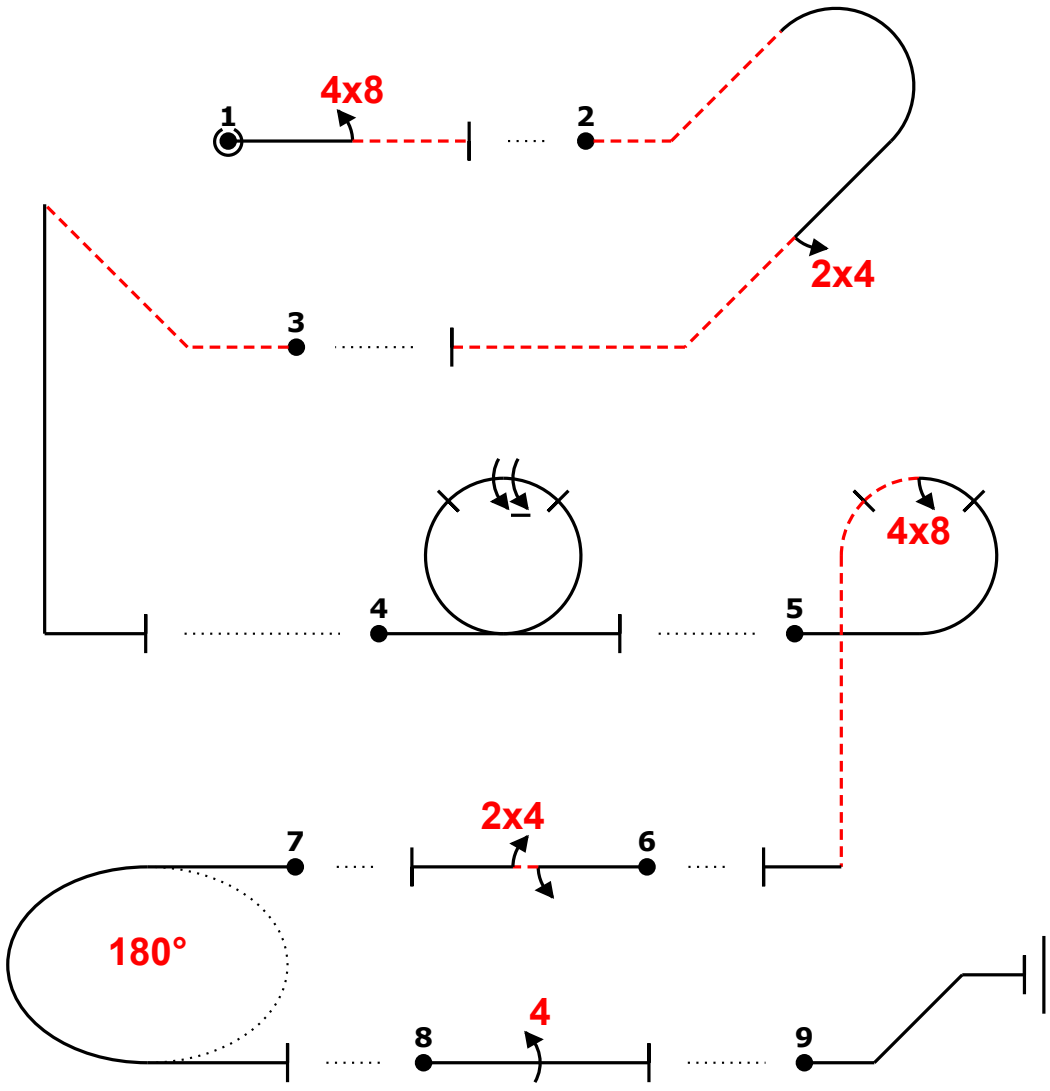
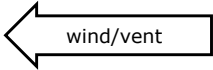

Glider			
Fig 1 F	1.1.1.3 9.8.3.2	2 11	13
Fig 2 C	8.4.18.2 9.4.4.2	14 8	22
Fig 3 D	1.2.2.2	13	13
Fig 4 A	7.4.1.1 9.1.3.8	10 18	28
Fig 5 B	8.6.22.1 9.8.3.2	13 11	24
Fig 6 G	1.1.1.1 9.1.3.2 9.4.3.2	2 6 8	16
Fig 7 Add.	2.2.1.1	4	5
Fig 8 E	1.1.1.1 9.4.3.4	2 17	19
Fig 9 Add.	1.1.2.1	7	5
Total K = 145 (max K = 160)			

5% "EF" 48- (2,0) "EC" -rdb'24... (-4,0) 3% "ED" -t... (8,0) "EA" o9 (5,0) "EB" ``p(48)... (-2,0) 3% "EG" 2,24 (-2,0) 8% "EL" 2j (3,0) 4% "EB" 44 (4,0) -2% "EL" d

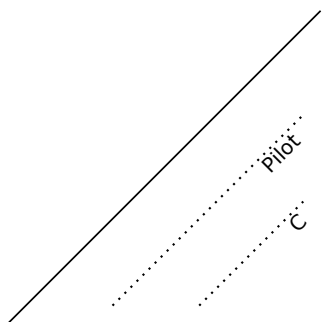

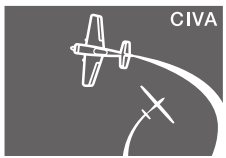

FAI

AEROBATICS COMMISSION

		Form B
Pilot ID	CIVA Glider Advanced FreeUnknown	Flight #

E

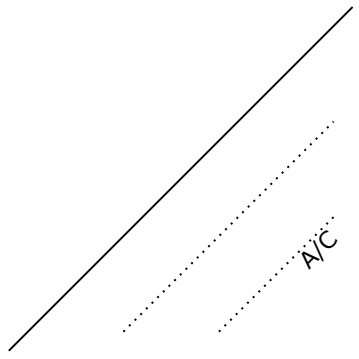
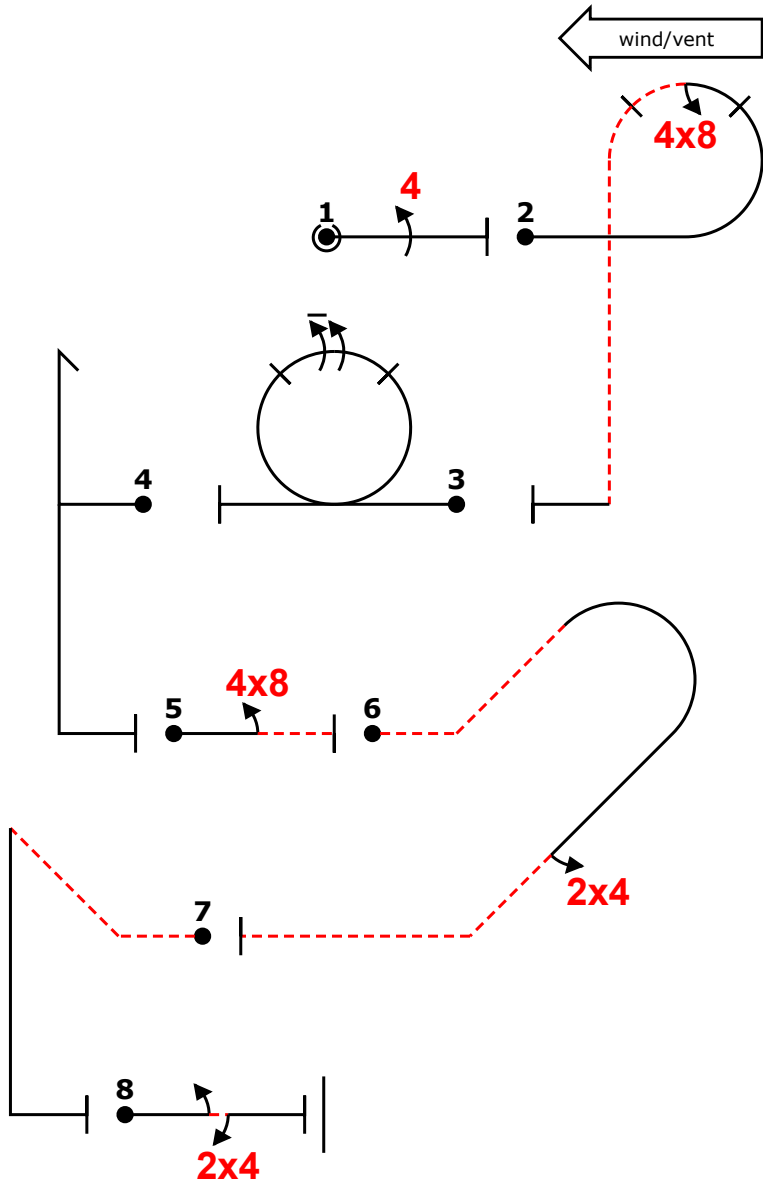

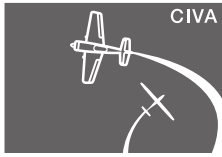

FAI

AEROBATICS COMMISSION

WAGAC 2018

Form B

Pilot ID

CIVA Glider Advanced FreeUnknown

F

Flight #

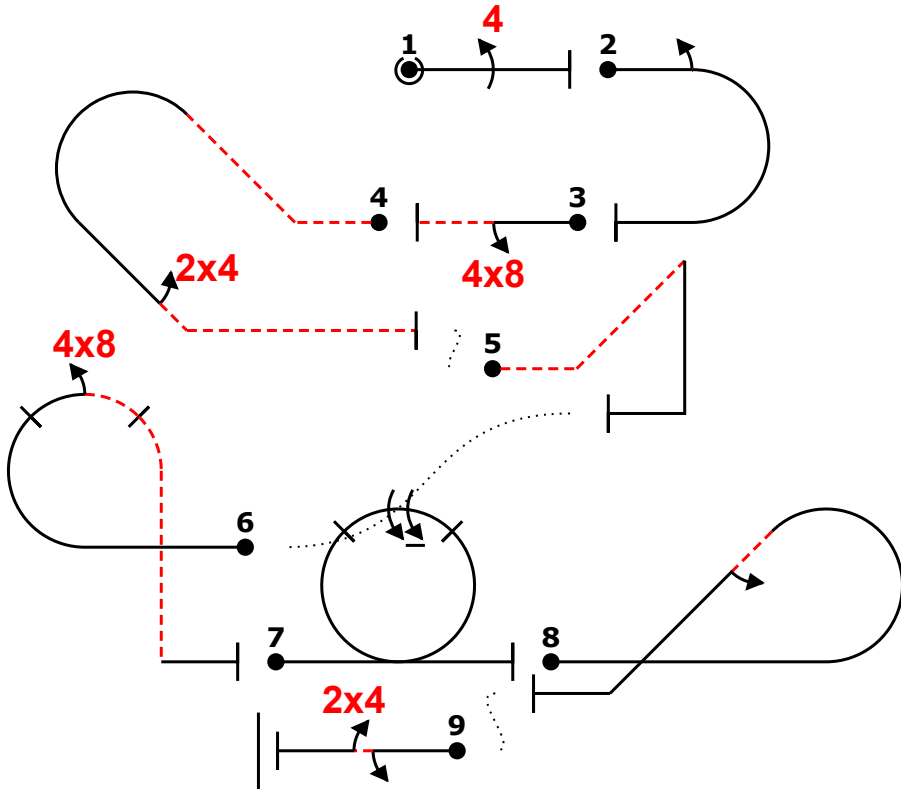
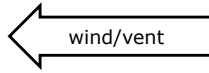

 Pilot
 A/C



WAGAC 2018		Form B
Pilot ID	CIVA Glider Advanced FreeUnknown	G
		Flight #

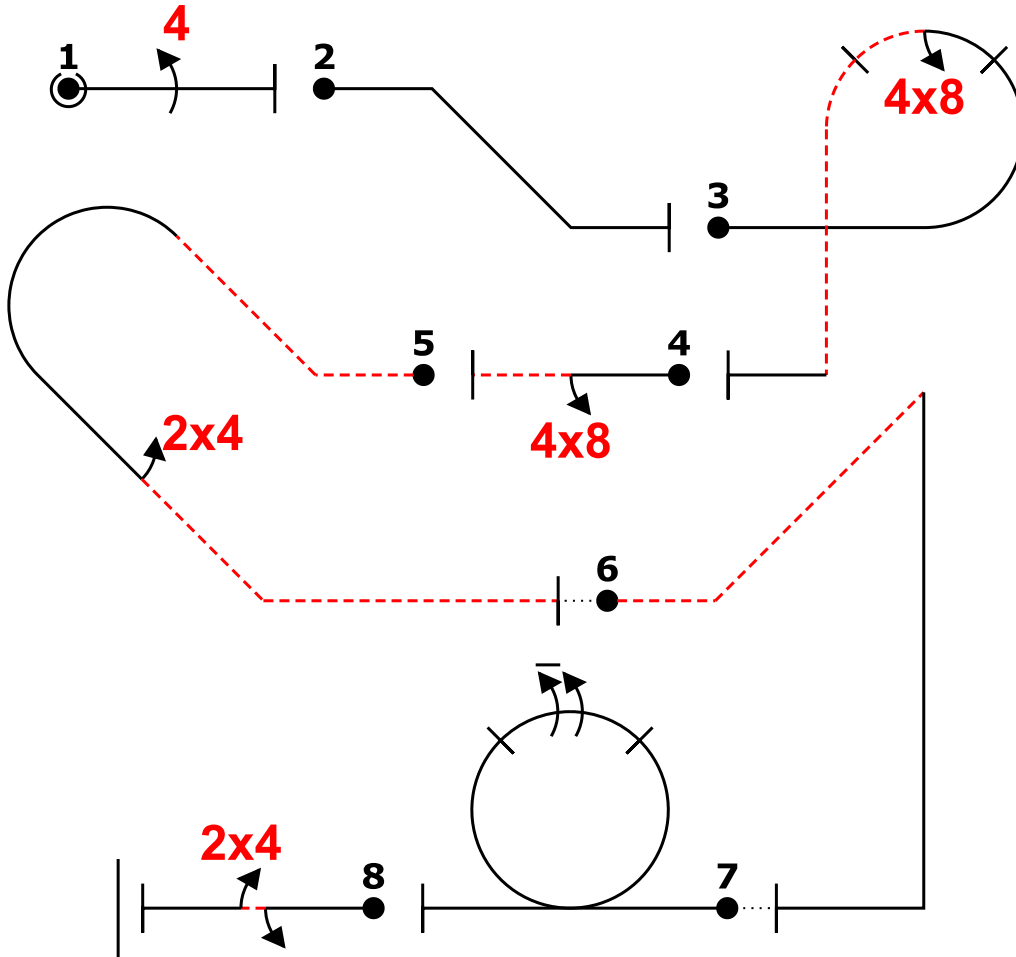
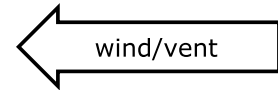

Glider			
Fig 1 E	1.1.1.1 9.4.3.4	2 17	19
Fig 2 Add.	1.1.2.3	7	10
Fig 3 B	8.6.22.1 9.8.3.2	13 11	24
Fig 4 F	1.1.1.3 9.8.3.2	2 11	13
Fig 5 C	8.4.18.2 9.4.4.2	14 8	22
Fig 6 D	1.2.2.2	13	13
Fig 7 A	7.4.1.1 9.1.3.8	10 18	28
Fig 8 G	1.1.1.1 9.1.3.2 9.4.3.2	2 6 8	16
Total K = 145 (max K = 160)			

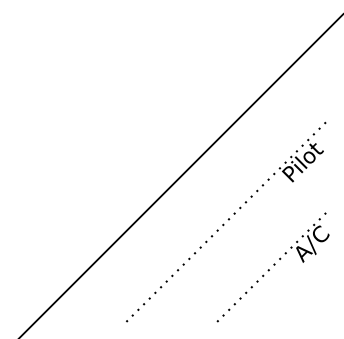



WAGAC 2018		Form B
Pilot ID	CIVA Glider Advanced FreeUnknown	Flight # H

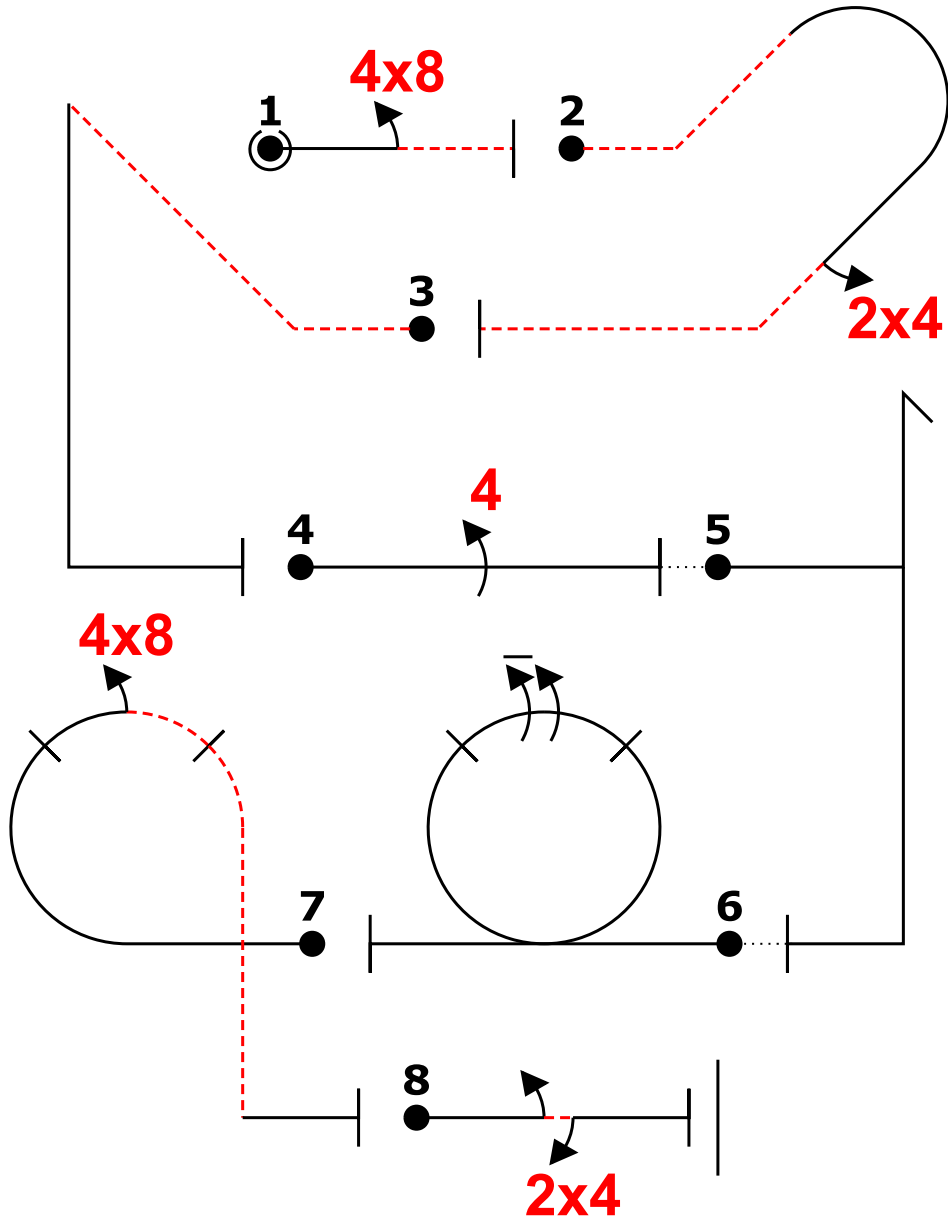
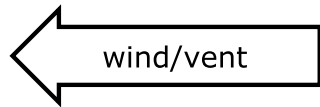

Glider			
Fig 1 F	1.1.1.3 9.8.3.2	2 11	13
Fig 2 C	8.4.18.2 9.4.4.2	14 8	22
Fig 3 D	1.2.2.2	13	13
Fig 4 E	1.1.1.1 9.4.3.4	2 17	19
Fig 5 Add.	5.2.1.1	17	10
Fig 6 A	7.4.1.1 9.1.3.8	10 18	28
Fig 7 B	8.6.22.1 9.8.3.2	13 11	24
Fig 8 G	1.1.1.1 9.1.3.2 9.4.3.2	2 6 8	16
Total K = 145 (max K = 160)			

Check: 3-8-2018 7:28 OpenAero 2018.3.8 2018 glider-civa advanced freeunknown Sequence is correct
 "@F" 48- "@C" -2% -'ndb24''- "@D" -.t..''~ "@E" ''44~ (-2,0) "@L" ~''h..' (2,0) "@A" o9 "@B" ''p(48) "@G" 2,24

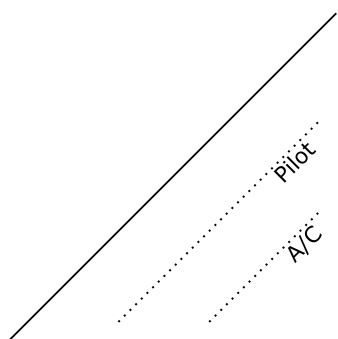



Zbraslavice 04.08.2018		Form B
Pilot ID	CIVA Glider Advanced FreeUnknown	Flight # I

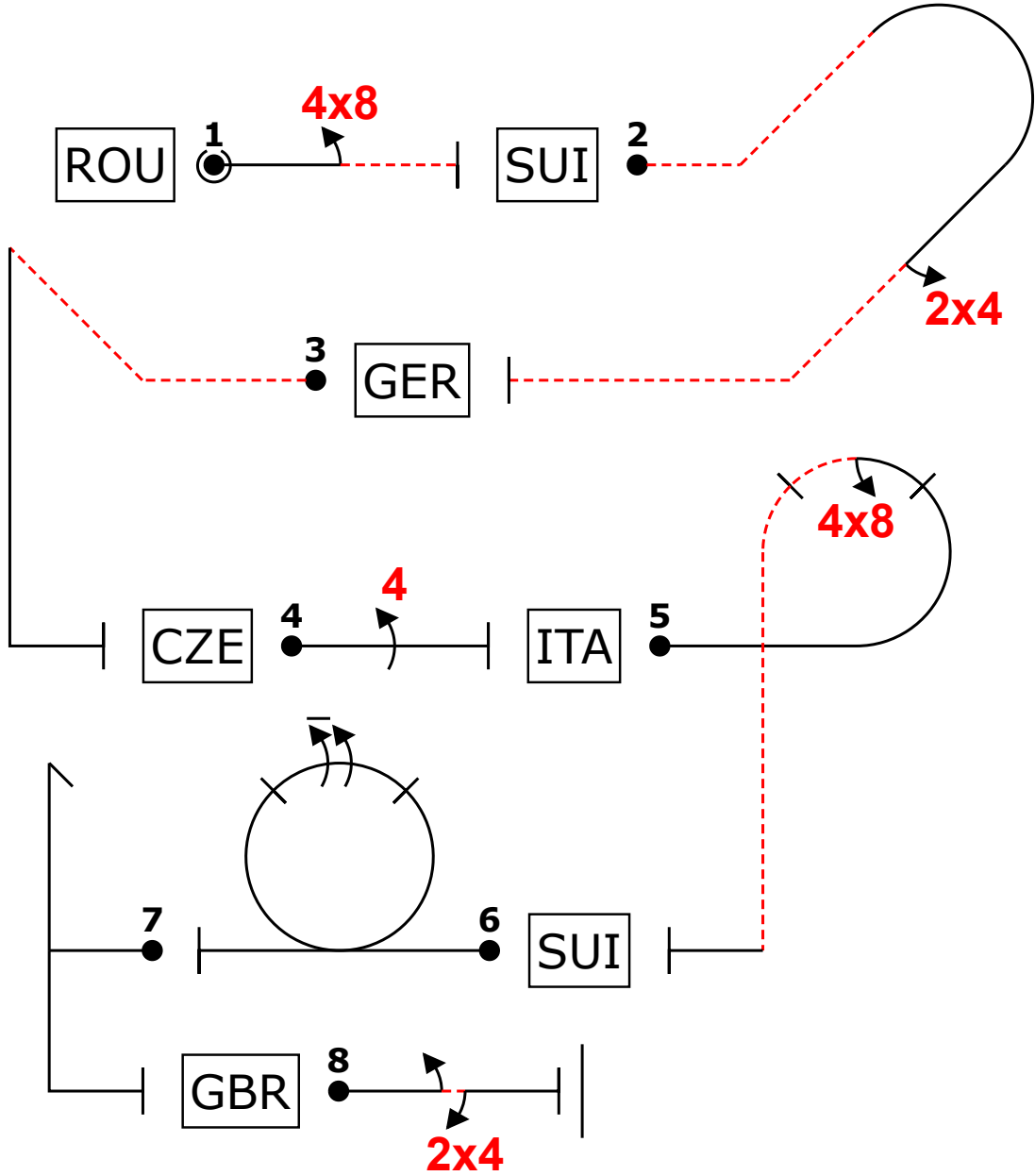
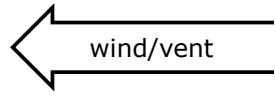

Glider			
Fig 1 A	1.1.1.3 9.8.3.2	2 11	13
Fig 2 B	8.4.18.2 9.4.4.2	14 8	22
Fig 3 C	1.2.2.2	13	13
Fig 4 D	1.1.1.1 9.4.3.4	2 17	19
Fig 5 E	8.6.22.1 9.8.3.2	13 11	24
Fig 6 F	7.4.1.1 9.1.3.8	10 18	28
Fig 7 Add.	5.2.1.1	17	10
Fig 8 G	1.1.1.1 9.1.3.2 9.4.3.2	2 6 8	16
Total K = 145 (max K = 160)			

Check: 4-8-2018 13:01 OpenAero 2018.3.8 2018 glider-civa advanced freeunknown Sequence is correct
 "@A" "ROU" '48~ "@B" "SUI" -rdb24.' '- "@C" "GER" --t... "@D" "CZE" 44 "@E" "ITA" p(48)... "@F" "SUI" o9 "@L" h "@G" "GBR" 2,24

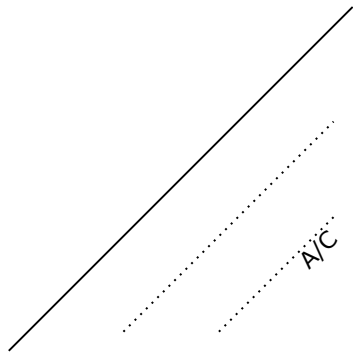

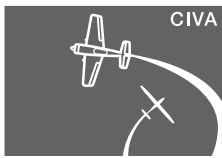

FAI AEROBATICS COMMISSION

LKZB AUG 2018		Form B
Pilot ID	CIVA Glider Advanced FreeUnknown	J
		Flight #

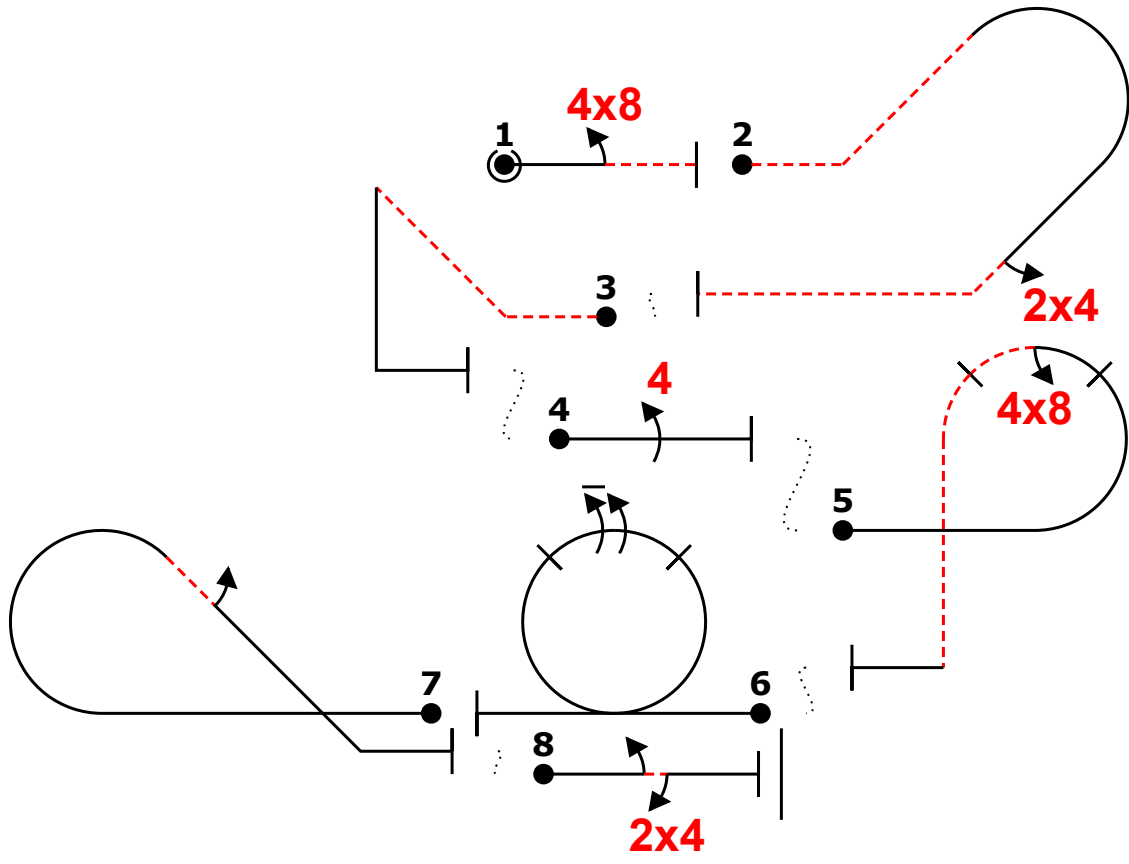
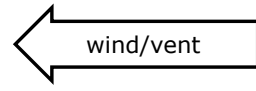

Glider			
Fig 1 F	1.1.1.3 9.8.3.2	2 11	13
Fig 2 C	8.4.18.2 9.4.4.2	14 8	22
Fig 3 D	1.2.2.2	13	13
Fig 4 E	1.1.1.1 9.4.3.4	2 17	19
Fig 5 B	8.6.22.1 9.8.3.2	13 11	24
Fig 6 A	7.4.1.1 9.1.3.8	10 18	28
Fig 7 Add.	8.5.6.1 9.1.4.2	10 6	10
Fig 8 G	1.1.1.1 9.1.3.2 9.4.3.2	2 6 8	16
Total K = 145 (max K = 160)			

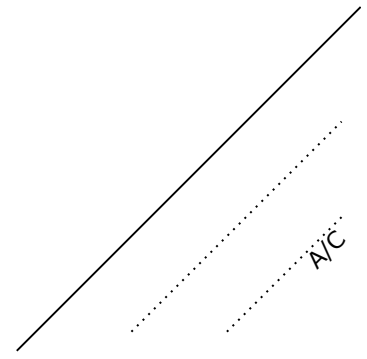

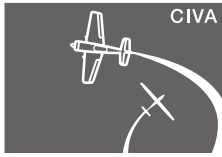

FAI

AEROBATICS
COMMISSION

Pilot ID

CIVA Glider Advanced FreeUnknown

K

Form B

Flight #

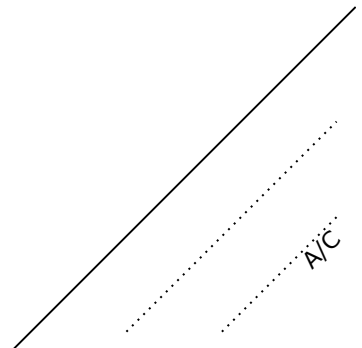
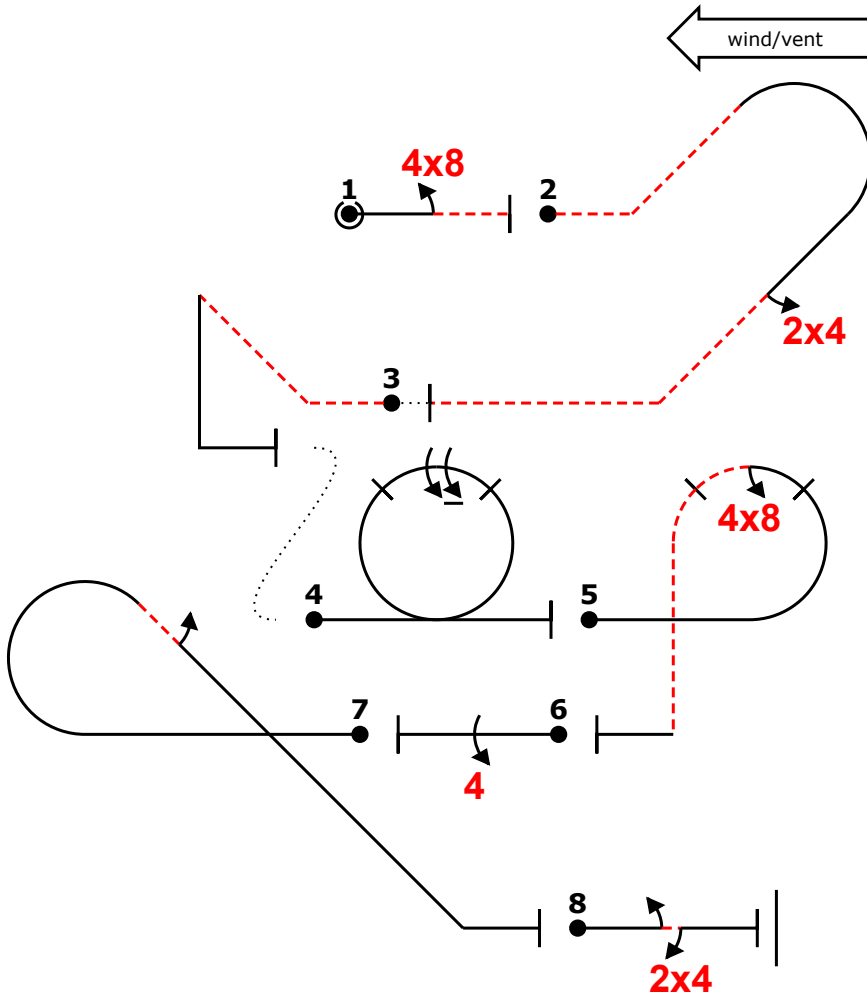

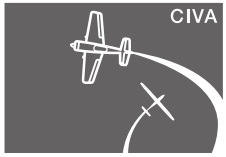

FAI AEROBATICS COMMISSION

WAGAC 2018

Form B

Pilot ID

CIVA Glider Advanced FreeUnknown **L**

Flight #

wind/vent ←

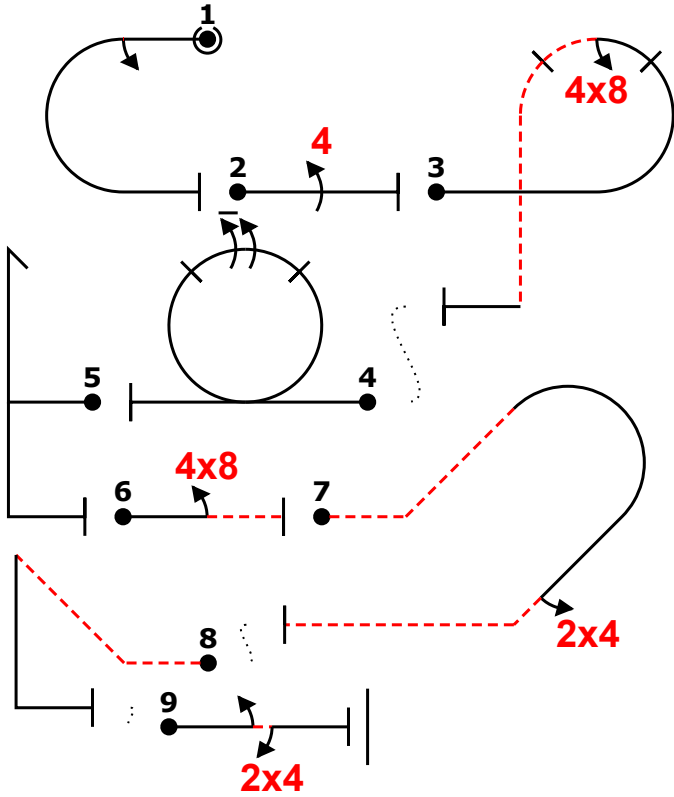

 Pilot
 A/C

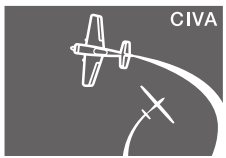

FAI AEROBATICS COMMISSION

WAGAC 2018		Form B
Pilot ID	CIVA Glider Advanced FreeUnknown	M
		Flight #

← wind/vent

