

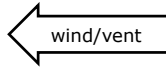

CIVA Advanced

Programme3



R

Figure K

339

Total K

369

Judges Name	
Signature	Number

Flight #
A

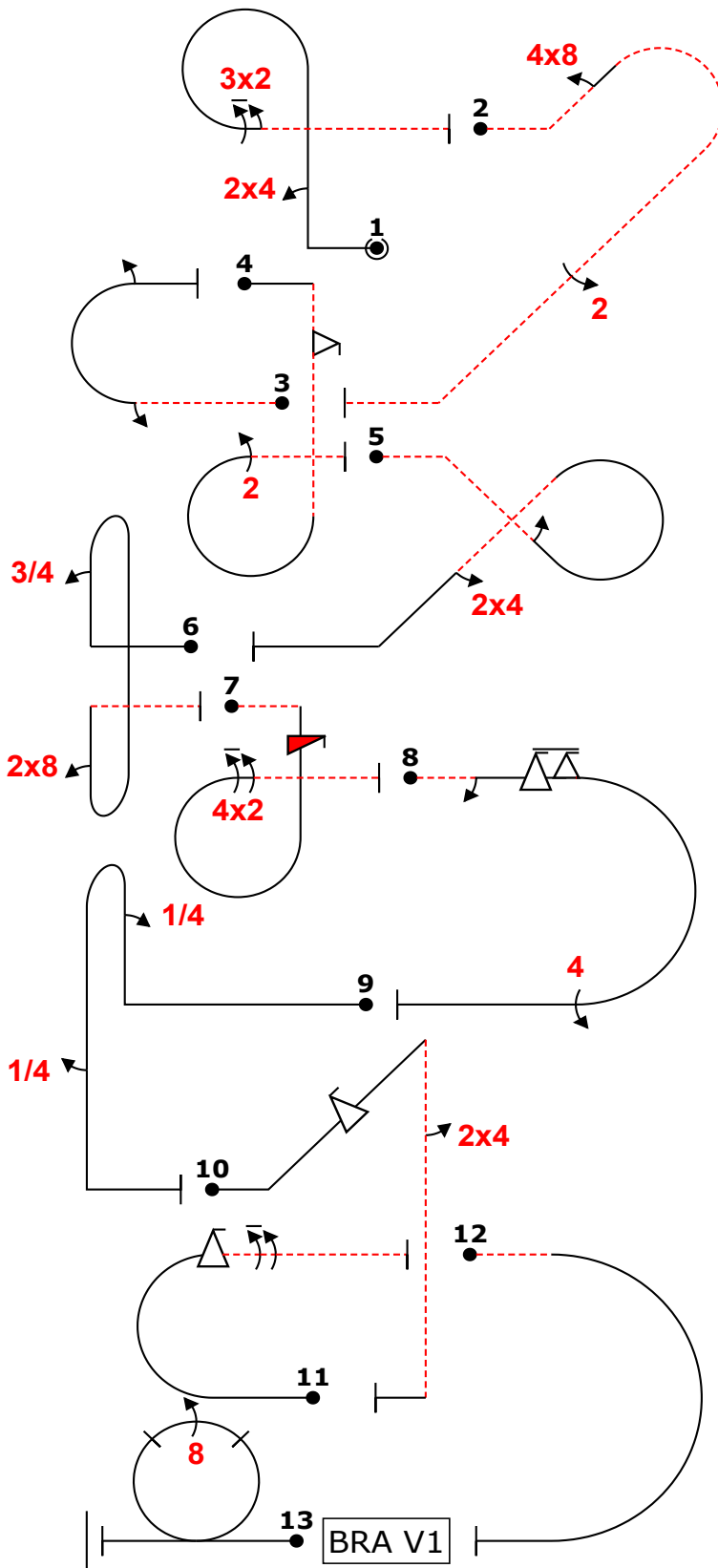

Fig	Grade	Pos	Remarks
1	.		
2	.		
3	.		
4	.		
5	.		
6	.		
7	.		
8	.		
9	.		
10	.		
11	.		
12	.		
13	.		

Positioning	30	.
-------------	----	---

Too Low		Trg Violation	
Too High		Wing Rocks	
Interruptions		Disqual Fig	
Insertions		Other(note...)	

Fig 1 G	K	Fig 2 A	K	Fig 3 L	K	Fig 4 D	K	Fig 5 I	K	Fig 6 H	K	Fig 7 F	K	Fig 8 B	K	Fig 9 L	K	Fig 10 E	K	Fig 11 C	K	Fig 12 L	K	Fig 13 J	K
8.6.2.1	12	8.4.15.2	16	7.2.4.2	6	8.6.3.3	13	7.3.4.4	15	8.8.1.1	18	8.6.1.4	12	7.2.1.4	6	8.4.1.1	13	1.2.1.1	13	7.2.1.1	6	7.2.1.4	6	7.4.1.1	10
9.4.1.2	9	9.8.2.2	9	9.1.3.2	4	9.9.10.2	13	9.1.4.2	4	9.1.1.3	10	9.12.1.4	7	9.1.3.2	4	9.1.1.1	6	9.9.2.4	13	9.9.3.4	11			9.8.3.4	15
9.2.3.6	12	9.2.4.4	9	9.1.3.2	4	9.2.3.4	9	9.4.4.2	5	9.8.1.1	7	9.2.3.8	15	9.9.3.6	14	9.1.5.1	2	9.4.5.2	5	9.1.3.8	12				
	33		34		8		35		24		35		34		35		8		31		29		8		25

Pilot:

A/C:

Team: **BRA**

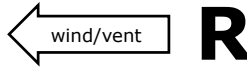

Figure K
 339
 Total K
 369

Judges Name	
Signature	Number

Flight #
B

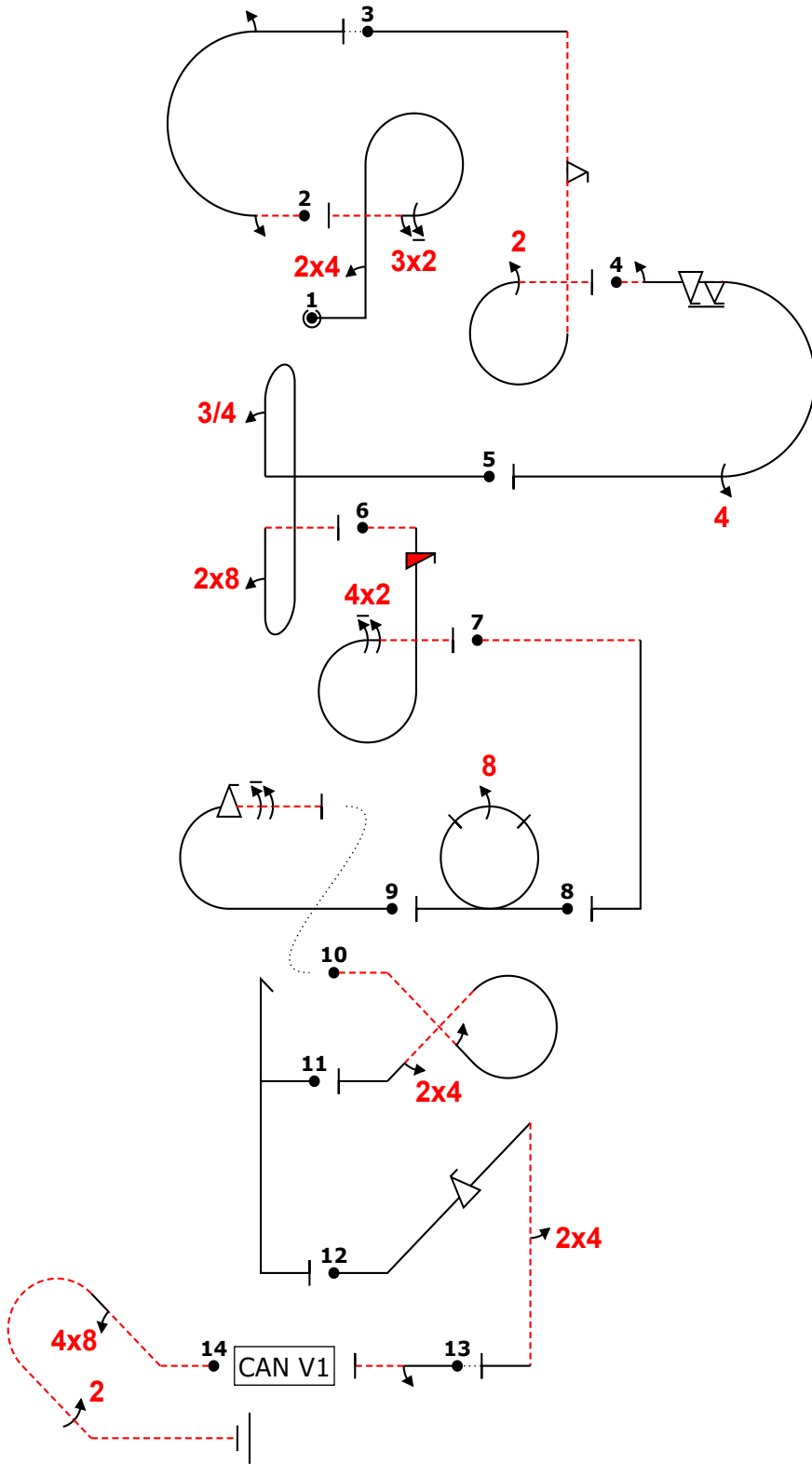

Fig	Grade	Pos	Remarks
1	.		
2	.		
3	.		
4	.		
5	.		
6	.		
7	.		
8	.		
9	.		
10	.		
11	.		
12	.		
13	.		
14	.		

Positioning
 30

Too Low		Trg Violation	
Too High		Wing Rocks	
Interruptions		Disqual Fig	
Insertions		Other(note...)	

Fig	1 G	K	Fig	2 L	K	Fig	3 D	K	Fig	4 B	K	Fig	5 H	K	Fig	6 F	K	Fig	7 L	K	Fig	8 J	K	Fig	9 C	K	Fig	10 I	K	Fig	11 L	K	Fig	12 E	K	Fig	13 L	K	Fig	14 A	K
8.6.2.1	12		7.2.4.2	6	8.6.3.3	13	7.2.1.4	6	8.8.1.1	18	8.6.1.4	12	1.1.7.4	9	7.4.1.1	10	7.2.1.1	6	7.3.4.4	15	5.2.1.1	17	1.2.1.1	13	1.1.1.3	2	8.4.15.2	16													
9.4.1.2	9		9.1.3.2	4	9.9.10.2	13	9.1.3.2	4	9.1.1.3	10	9.12.1.4	7			9.8.3.4	15	9.9.3.4	11	9.1.4.2	4			9.9.2.4	13	9.1.3.2	4	9.8.2.2	9													
9.2.3.6	12		9.1.3.2	4	9.2.3.4	9	9.9.3.6	14	9.8.1.1	7	9.2.3.8	15					9.1.3.8	12	9.4.4.2	5			9.4.5.2	5			9.2.4.4	9													
	33			6		35	9.4.3.4	11		35		34		6		25		29		24		6		31		6		34													

Pilot:

A/C:



Figure K
 339
 Total K
 369

Judges Name	
Signature	Number

Flight #
B

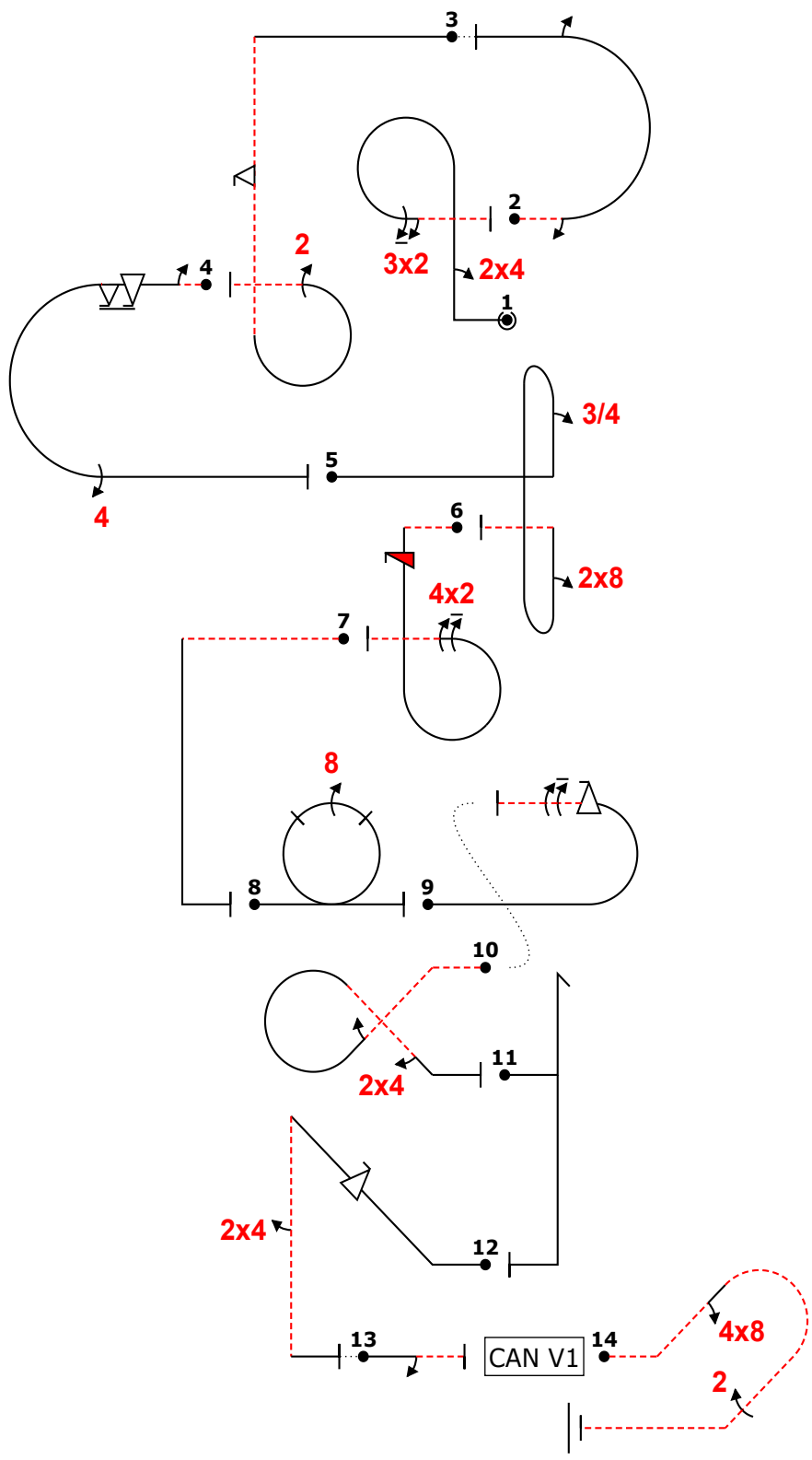
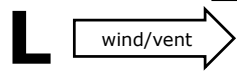

Fig	Grade	Pos	Remarks
1	.		
2	.		
3	.		
4	.		
5	.		
6	.		
7	.		
8	.		
9	.		
10	.		
11	.		
12	.		
13	.		
14	.		

Positioning
 30

Too Low		Trg Violation	
Too High		Wing Rocks	
Interruptions		Disqual Fig	
Insertions		Other(note...)	

Fig 1 G	K	Fig 2 L	K	Fig 3 D	K	Fig 4 B	K	Fig 5 H	K	Fig 6 F	K	Fig 7 L	K	Fig 8 J	K	Fig 9 C	K	Fig 10 I	K	Fig 11 L	K	Fig 12 E	K	Fig 13 L	K	Fig 14 A	K
8.6.2.1	12	7.2.4.2	6	8.6.3.3	13	7.2.1.4	6	8.8.1.1	18	8.6.1.4	12	1.1.7.4	9	7.4.1.1	10	7.2.1.1	6	7.3.4.4	15	5.2.1.1	17	1.2.1.1	13	1.1.1.3	2	8.4.15.2	16
9.4.1.2	9	9.1.3.2	4	9.9.10.2	13	9.1.3.2	4	9.1.1.3	10	9.12.1.4	7			9.8.3.4	15	9.9.3.4	11	9.1.4.2	4			9.9.2.4	13	9.1.3.2	4	9.8.2.2	9
9.2.3.6	12	9.1.3.2	4	9.2.3.4	9	9.9.3.6	14	9.8.1.1	7	9.2.3.8	15					9.1.3.8	12	9.4.4.2	5			9.4.5.2	5			9.2.4.4	9
	33		6		35		35		35		34		6		25		29		24		6		31		6		34

Pilot:

A/C:



wind/vent ← **R**

Figure K
339
 Total K
369

Judges Name	
Signature	Number

Flight #
C

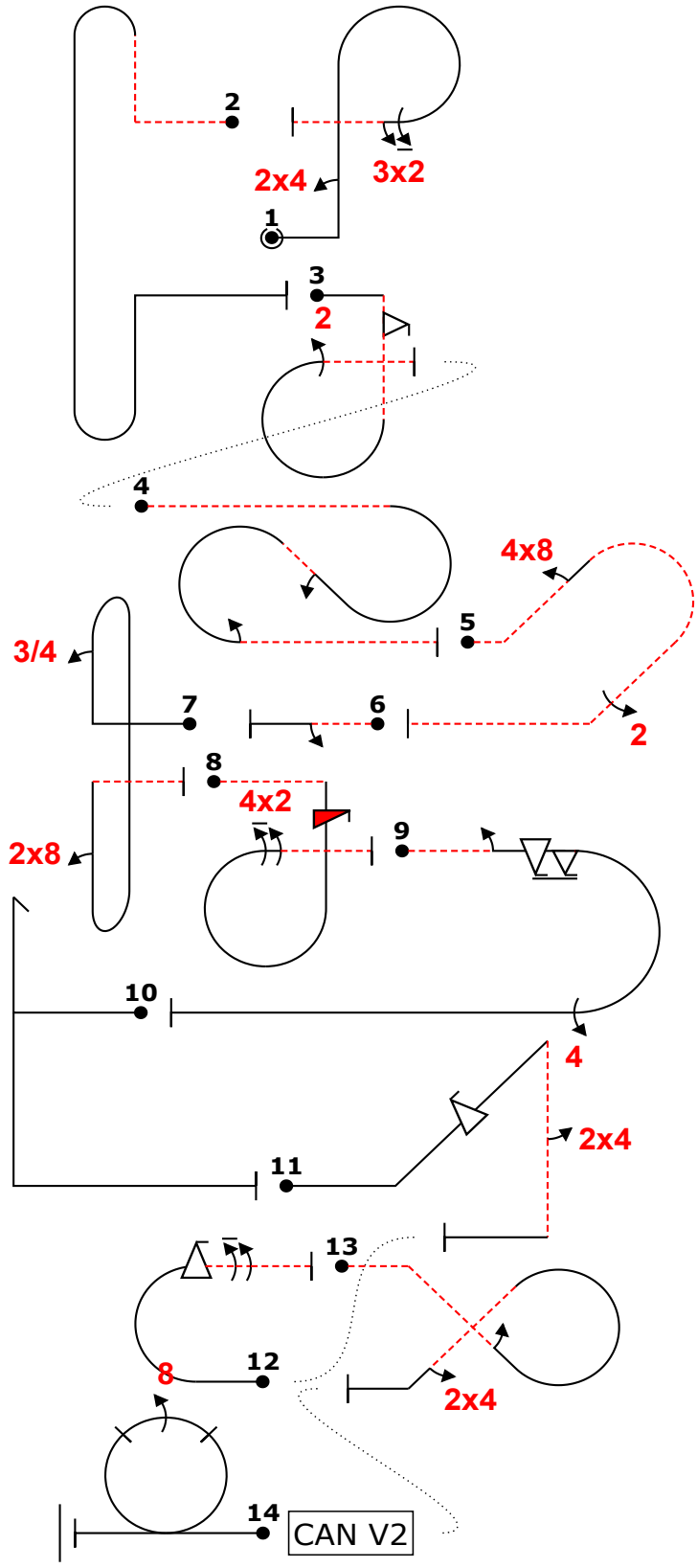

Fig	Grade	Pos	Remarks
1	.		
2	.		
3	.		
4	.		
5	.		
6	.		
7	.		
8	.		
9	.		
10	.		
11	.		
12	.		
13	.		
14	.		

Positioning
30

Too Low		Trg Violation	
Too High		Wing Rocks	
Interruptions		Disqual Fig	
Insertions		Other(note...)	

Fig 1 G	K	Fig 2 L	K	Fig 3 D	K	Fig 4 L	K	Fig 5 A	K	Fig 6 L	K	Fig 7 H	K	Fig 8 F	K	Fig 9 B	K	Fig 10 L	K	Fig 11 E	K	Fig 12 C	K	Fig 13 I	K	Fig 14 J	K
8.6.2.1	12	8.8.7.2	21	8.6.3.3	13	7.5.7.4	15	8.4.15.2	16	1.1.1.4	2	8.8.1.1	18	8.6.1.4	12	7.2.1.4	6	5.2.1.1	17	1.2.1.1	13	7.2.1.1	6	7.3.4.4	15	7.4.1.1	10
9.4.1.2	9			9.9.10.2	13	9.1.2.2	6	9.8.2.2	9	9.1.3.2	4	9.1.1.3	10	9.12.1.4	7	9.1.3.2	4			9.9.2.4	13	9.9.3.4	11	9.1.4.2	4	9.8.3.4	15
9.2.3.6	12			9.2.3.4	9	9.1.3.2	4	9.2.4.4	9			9.8.1.1	7	9.2.3.8	15	9.9.3.6	14			9.4.5.2	5	9.1.3.8	12	9.4.4.2	5		
	33		6		35		6		34		6		35		34		35		6		31		29		24		25

Pilot:

A/C:

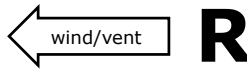

Figure K
339
 Total K
369

Judges Name	
Signature	Number

Flight #
D

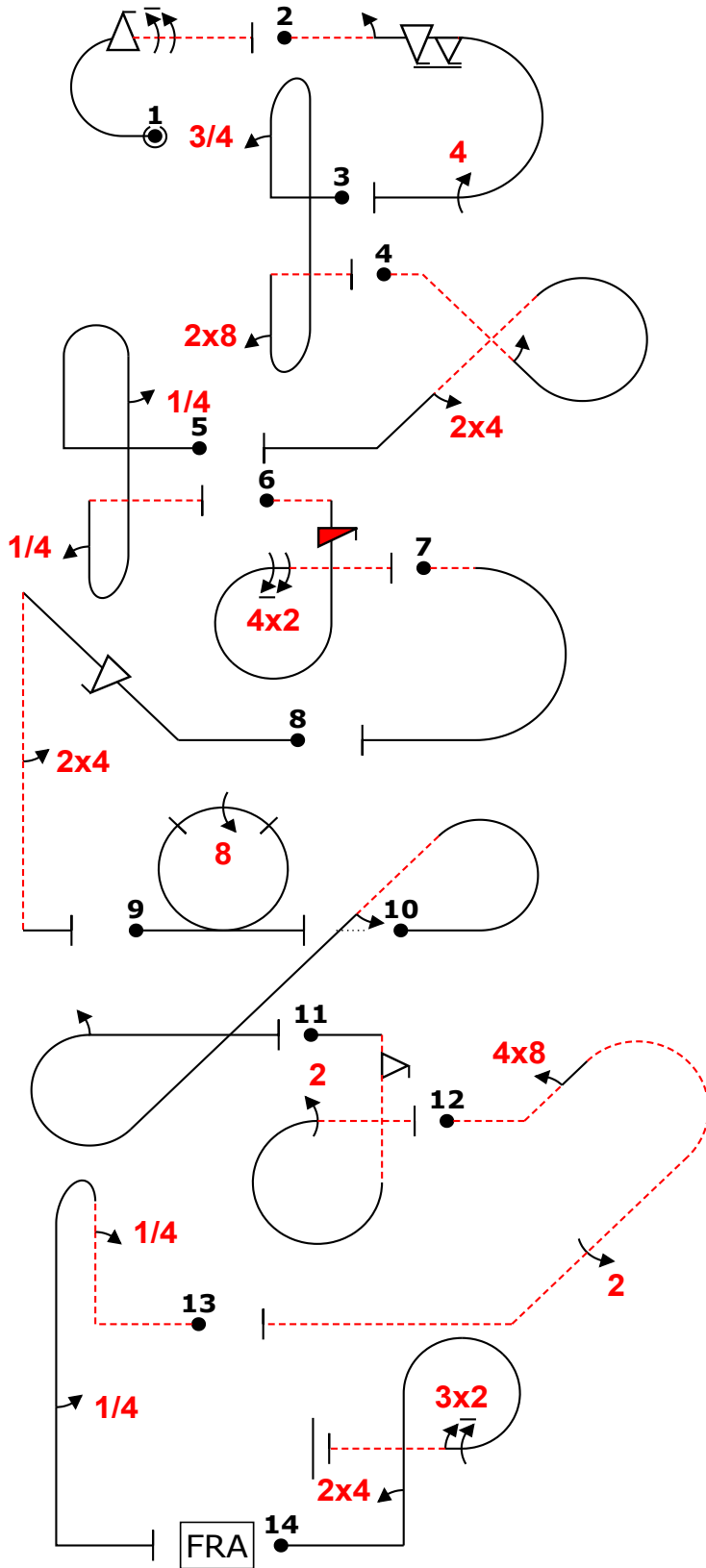

Fig	Grade	Pos	Remarks
1	.		
2	.		
3	.		
4	.		
5	.		
6	.		
7	.		
8	.		
9	.		
10	.		
11	.		
12	.		
13	.		
14	.		

Positioning
30

Too Low		Trg Violation	
Too High		Wing Rocks	
Interruptions		Disqual Fig	
Insertions		Other(note...)	

Fig 1 C	K	Fig 2 B	K	Fig 3 H	K	Fig 4 I	K	Fig 5 L	K	Fig 6 F	K	Fig 7 L	K	Fig 8 E	K	Fig 9 J	K	Fig 10 L	K	Fig 11 D	K	Fig 12 A	K	Fig 13 L	K	Fig 14 G	K
7.2.1.1	6	7.2.1.4	6	8.8.1.1	18	7.3.4.4	15	8.8.1.1	18	8.6.1.4	12	7.2.1.4	6	1.2.1.1	13	7.4.1.1	10	7.5.7.1	15	8.6.3.3	13	8.4.15.2	16	8.4.4.2	14	8.6.2.1	12
9.9.3.4	11	9.1.3.2	4	9.1.1.3	10	9.1.4.2	4	9.1.5.1	2	9.12.1.4	7			9.9.2.4	13	9.8.3.4	15	9.1.4.2	4	9.9.10.2	13	9.8.2.2	9	9.1.1.1	6	9.4.1.2	9
9.1.3.8	12	9.9.3.6	14	9.8.1.1	7	9.4.4.2	5	9.1.1.1	6	9.2.3.8	15			9.4.5.2	5			9.1.3.2	4	9.2.3.4	9	9.2.4.4	9	9.1.5.1	2	9.2.3.6	12
	29	9.4.3.4	35		35		24		6		34		6		31		25		6		35		34		6		33

Pilot:

A/C:



Figure K
339
 Total K
369

Judges Name	
Signature	Number

Flight #
D

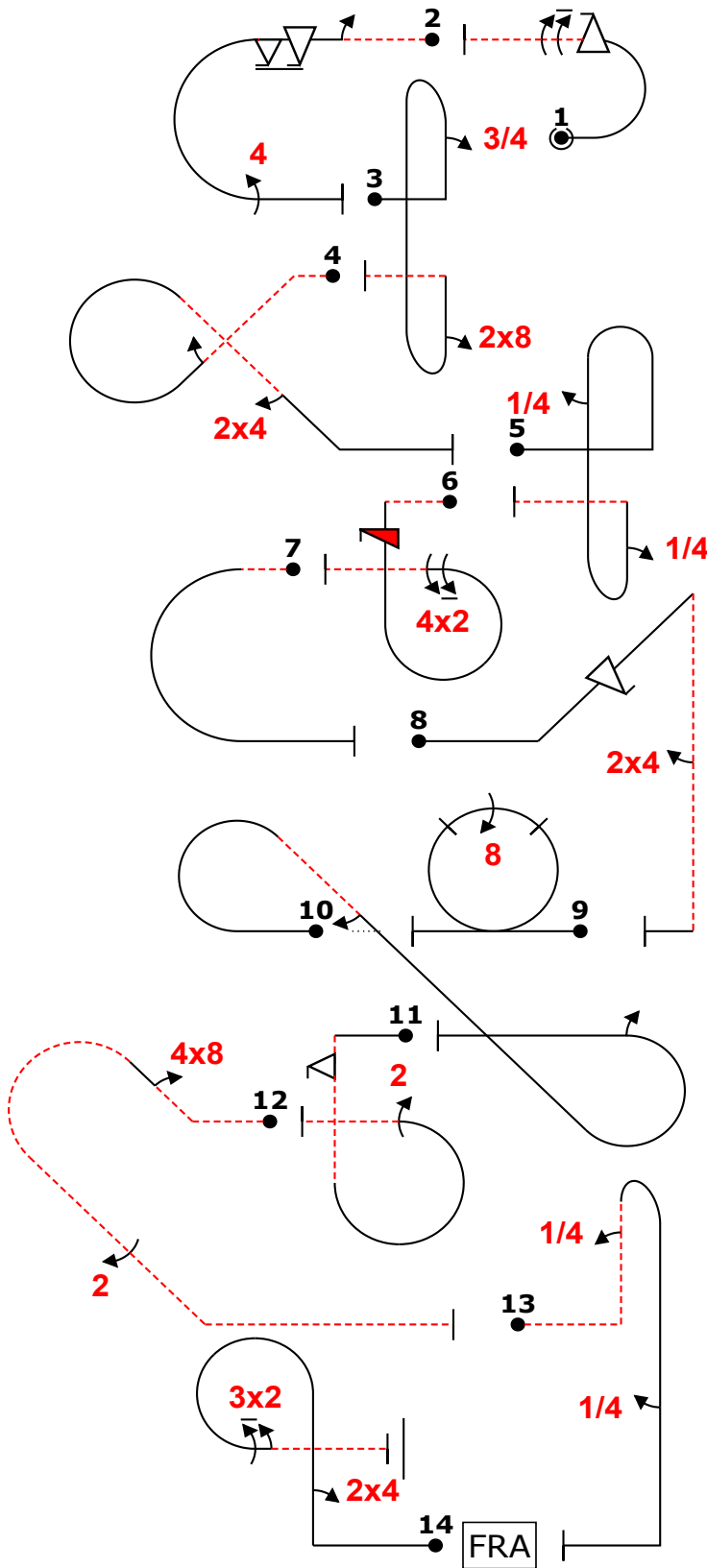
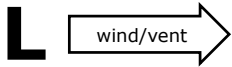

Fig	Grade	Pos	Remarks
1	.		
2	.		
3	.		
4	.		
5	.		
6	.		
7	.		
8	.		
9	.		
10	.		
11	.		
12	.		
13	.		
14	.		

Positioning
30

Too Low		Trg Violation	
Too High		Wing Rocks	
Interruptions		Disqual Fig	
Insertions		Other(note...)	

Fig 1 C	K	Fig 2 B	K	Fig 3 H	K	Fig 4 I	K	Fig 5 L	K	Fig 6 F	K	Fig 7 L	K	Fig 8 E	K	Fig 9 J	K	Fig 10 L	K	Fig 11 D	K	Fig 12 A	K	Fig 13 L	K	Fig 14 G	K
7.2.1.1	6	7.2.1.4	6	8.8.1.1	18	7.3.4.4	15	8.8.1.1	18	8.6.1.4	12	7.2.1.4	6	1.2.1.1	13	7.4.1.1	10	7.5.7.1	15	8.6.3.3	13	8.4.15.2	16	8.4.4.2	14	8.6.2.1	12
9.9.3.4	11	9.1.3.2	4	9.1.1.3	10	9.1.4.2	4	9.1.5.1	2	9.12.1.4	7			9.9.2.4	13	9.8.3.4	15	9.1.4.2	4	9.9.10.2	13	9.8.2.2	9	9.1.1.1	6	9.4.1.2	9
9.1.3.8	12	9.9.3.6	14	9.8.1.1	7	9.4.4.2	5	9.1.1.1	6	9.2.3.8	15			9.4.5.2	5			9.1.3.2	4	9.2.3.4	9	9.2.4.4	9	9.1.5.1	2	9.2.3.6	12
		9.4.3.4	11																								
	29		35		35		24		6		34		6		31		25		6		35		34		6		33

Pilot:

A/C:

wind/vent ← **R**

Figure K
339
 Total K
369

Judges Name	
Signature	Number

Flight #
E

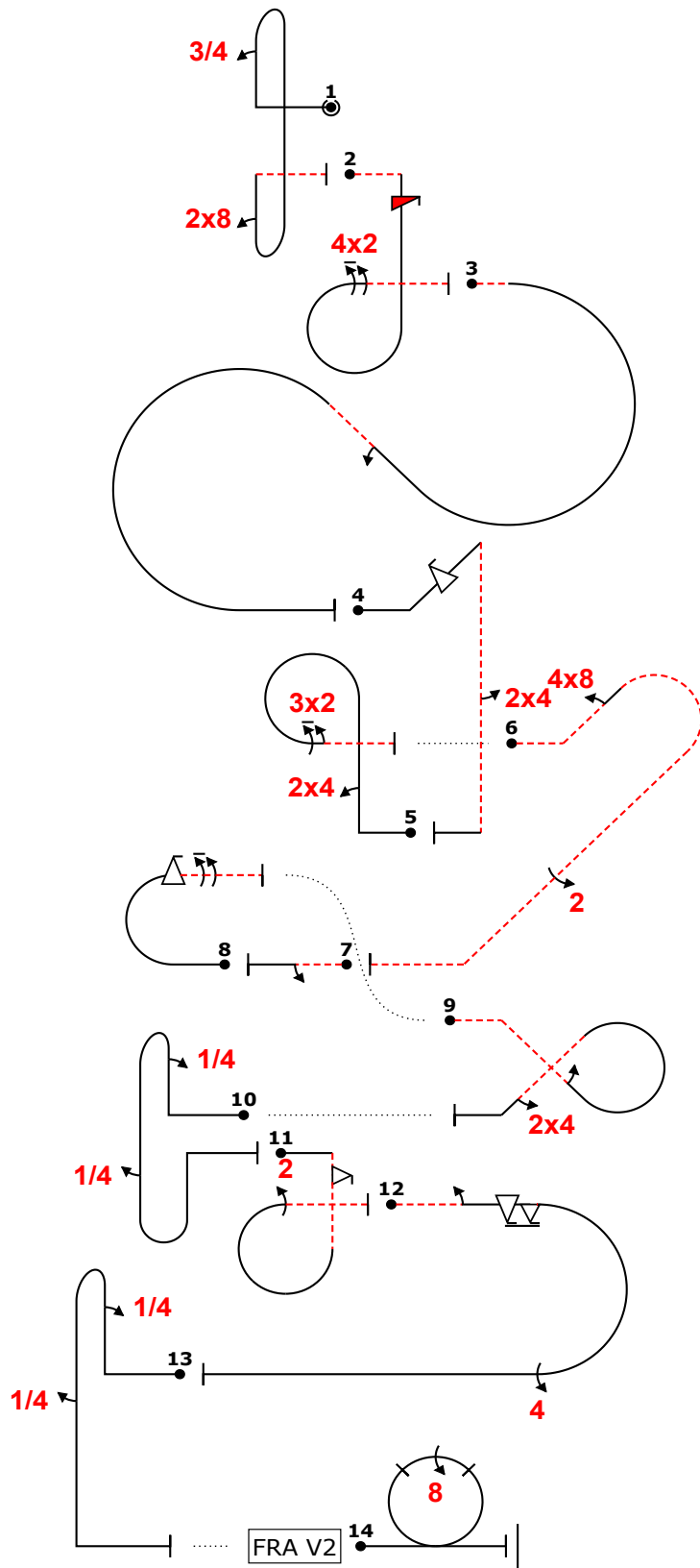

Fig	Grade	Pos	Remarks
1	.		
2	.		
3	.		
4	.		
5	.		
6	.		
7	.		
8	.		
9	.		
10	.		
11	.		
12	.		
13	.		
14	.		

Positioning
30

Too Low		Trg Violation	
Too High		Wing Rocks	
Interruptions		Disqual Fig	
Insertions		Other(note...)	

Fig 1 H	K	Fig 2 F	K	Fig 3 L	K	Fig 4 E	K	Fig 5 G	K	Fig 6 A	K	Fig 7 L	K	Fig 8 C	K	Fig 9 I	K	Fig 10 L	K	Fig 11 D	K	Fig 12 B	K	Fig 13 L	K	Fig 14 J	K
8.8.1.1	18	8.6.1.4	12	7.5.2.4	15	1.2.1.1	13	8.6.2.1	12	8.4.15.2	16	1.1.1.4	2	7.2.1.1	6	7.3.4.4	15	8.8.2.1	19	8.6.3.3	13	7.2.1.4	6	8.4.1.1	13	7.4.1.1	10
9.1.1.3	10	9.12.1.4	7	9.1.2.2	6	9.9.2.4	13	9.4.1.2	9	9.8.2.2	9	9.1.3.2	4	9.9.3.4	11	9.1.4.2	4	9.1.1.1	6	9.9.10.2	13	9.1.3.2	4	9.1.1.1	6	9.8.3.4	15
9.8.1.1	7	9.2.3.8	15			9.4.5.2	5	9.2.3.6	12	9.2.4.4	9			9.1.3.8	12	9.4.4.2	5	9.1.5.1	2	9.2.3.4	9	9.9.3.6	14	9.1.5.1	2		
	35		34		6		31		33		34		6		29		24		6		35		6		25		

Pilot: **France**

A/C:

Team: **FRA**

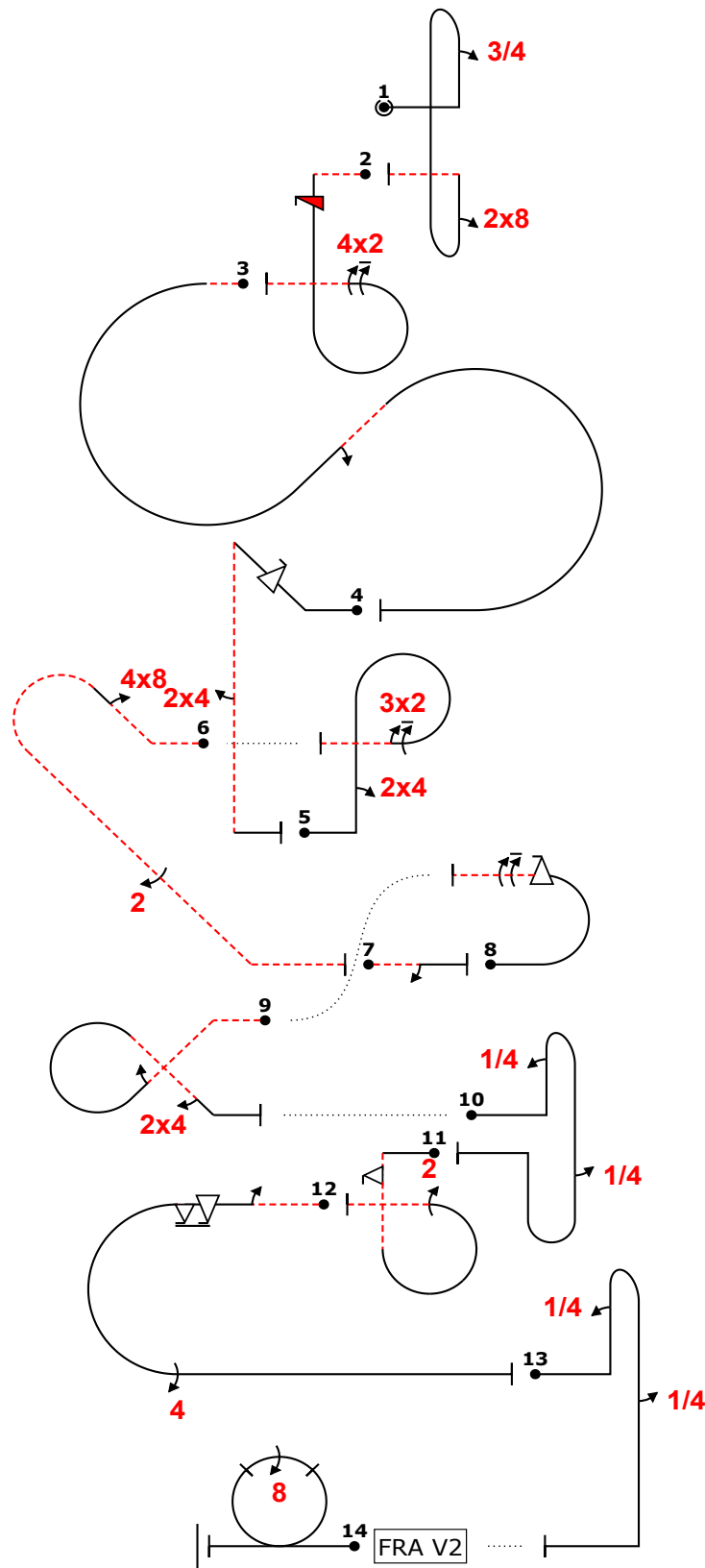
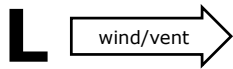

Fig	Grade	Pos	Remarks
1	.		
2	.		
3	.		
4	.		
5	.		
6	.		
7	.		
8	.		
9	.		
10	.		
11	.		
12	.		
13	.		
14	.		

Positioning	30	.
Too Low		Trg Violation
Too High		Wing Rocks
Interruptions		Disqual Fig
Insertions		Other(note...)

Fig 1 H	K	Fig 2 F	K	Fig 3 L	K	Fig 4 E	K	Fig 5 G	K	Fig 6 A	K	Fig 7 L	K	Fig 8 C	K	Fig 9 I	K	Fig 10 L	K	Fig 11 D	K	Fig 12 B	K	Fig 13 L	K	Fig 14 J	K
8.8.1.1	18	8.6.1.4	12	7.5.2.4	15	1.2.1.1	13	8.6.2.1	12	8.4.15.2	16	1.1.1.4	2	7.2.1.1	6	7.3.4.4	15	8.8.2.1	19	8.6.3.3	13	7.2.1.4	6	8.4.1.1	13	7.4.1.1	10
9.1.1.3	10	9.12.1.4	7	9.1.2.2	6	9.9.2.4	13	9.4.1.2	9	9.8.2.2	9	9.1.3.2	4	9.9.3.4	11	9.1.4.2	4	9.1.1.1	6	9.9.10.2	13	9.1.3.2	4	9.1.1.1	6	9.8.3.4	15
9.8.1.1	7	9.2.3.8	15			9.4.5.2	5	9.2.3.6	12	9.2.4.4	9			9.1.3.8	12	9.4.4.2	5	9.1.5.1	2	9.2.3.4	9	9.9.3.6	14	9.1.5.1	2		
	35		34		6		31		33		34		6		29		24		6		35		35		6		25

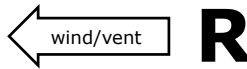

Figure K
339
 Total K
369

Judges Name	
Signature	Number

Flight # F

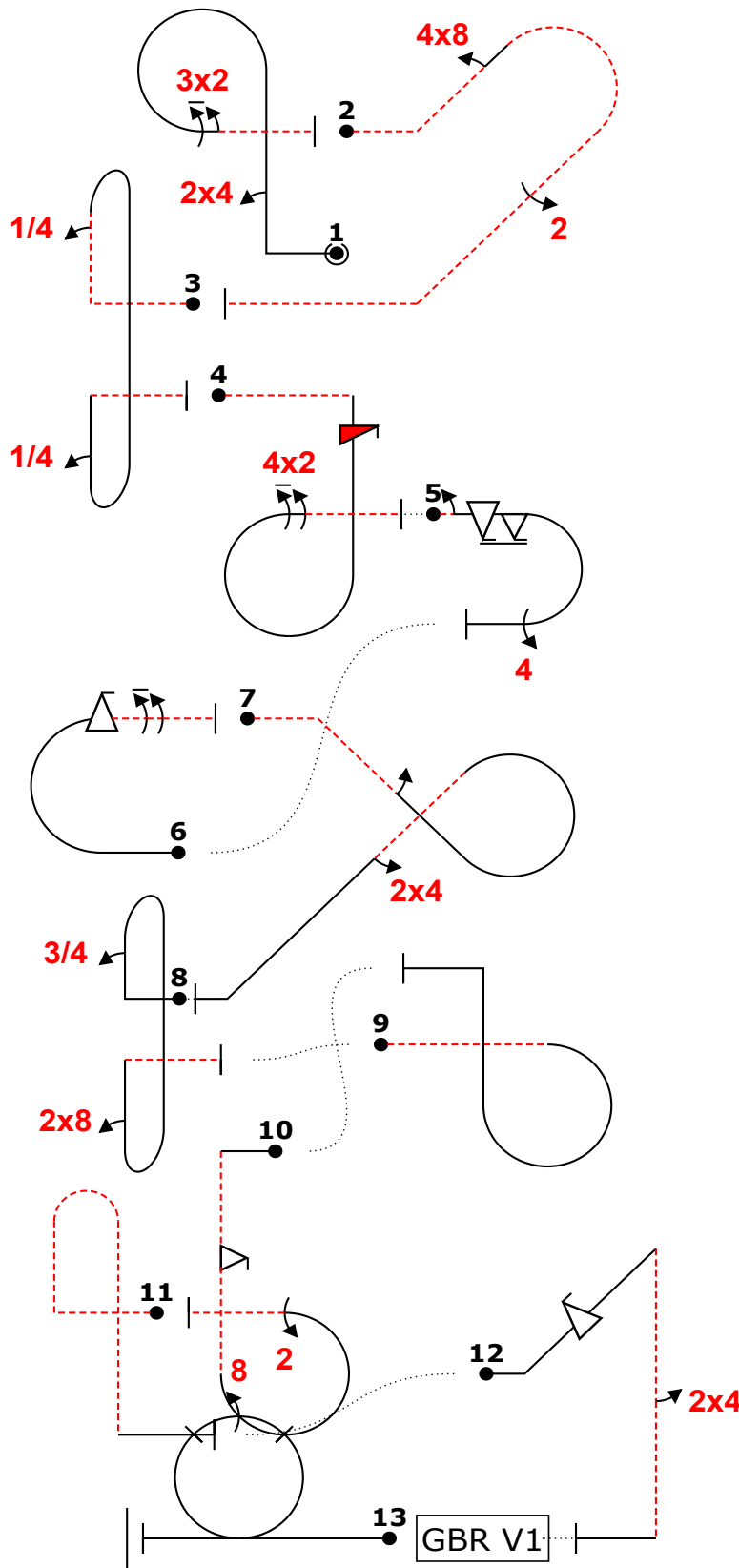

Fig	Grade	Pos	Remarks
1	.		
2	.		
3	.		
4	.		
5	.		
6	.		
7	.		
8	.		
9	.		
10	.		
11	.		
12	.		
13	.		

Positioning
30

Too Low		Trg Violation	
Too High		Wing Rocks	
Interruptions		Disqual Fig	
Insertions		Other(note...)	

Fig 1 G	K	Fig 2 A	K	Fig 3 L	K	Fig 4 F	K	Fig 5 B	K	Fig 6 C	K	Fig 7 I	K	Fig 8 H	K	Fig 9 L	K	Fig 10 D	K	Fig 11 L	K	Fig 12 E	K	Fig 13 J	K
8.6.2.1	12	8.4.15.2	16	8.8.8.2	20	8.6.1.4	12	7.2.1.4	6	7.2.1.1	6	7.3.4.4	15	8.8.1.1	18	8.6.6.4	13	8.6.3.3	13	8.4.2.2	17	1.2.1.1	13	7.4.1.1	10
9.4.1.2	9	9.8.2.2	9	9.1.1.1	6	9.12.1.4	7	9.1.3.2	4	9.9.3.4	11	9.1.4.2	4	9.1.1.3	10			9.9.10.2	13			9.9.2.4	13	9.8.3.4	15
9.2.3.6	12	9.2.4.4	9	9.1.1.1	6	9.2.3.8	15	9.9.3.6	14	9.1.3.8	12	9.4.4.2	5	9.8.1.1	7			9.2.3.4	9			9.4.5.2	5		
	33		34		8		34		35		29		24		35		8		35		8		31		25

Pilot:

A/C:



Figure K
339
 Total K
369

Judges Name	
Signature	Number

Flight #
F

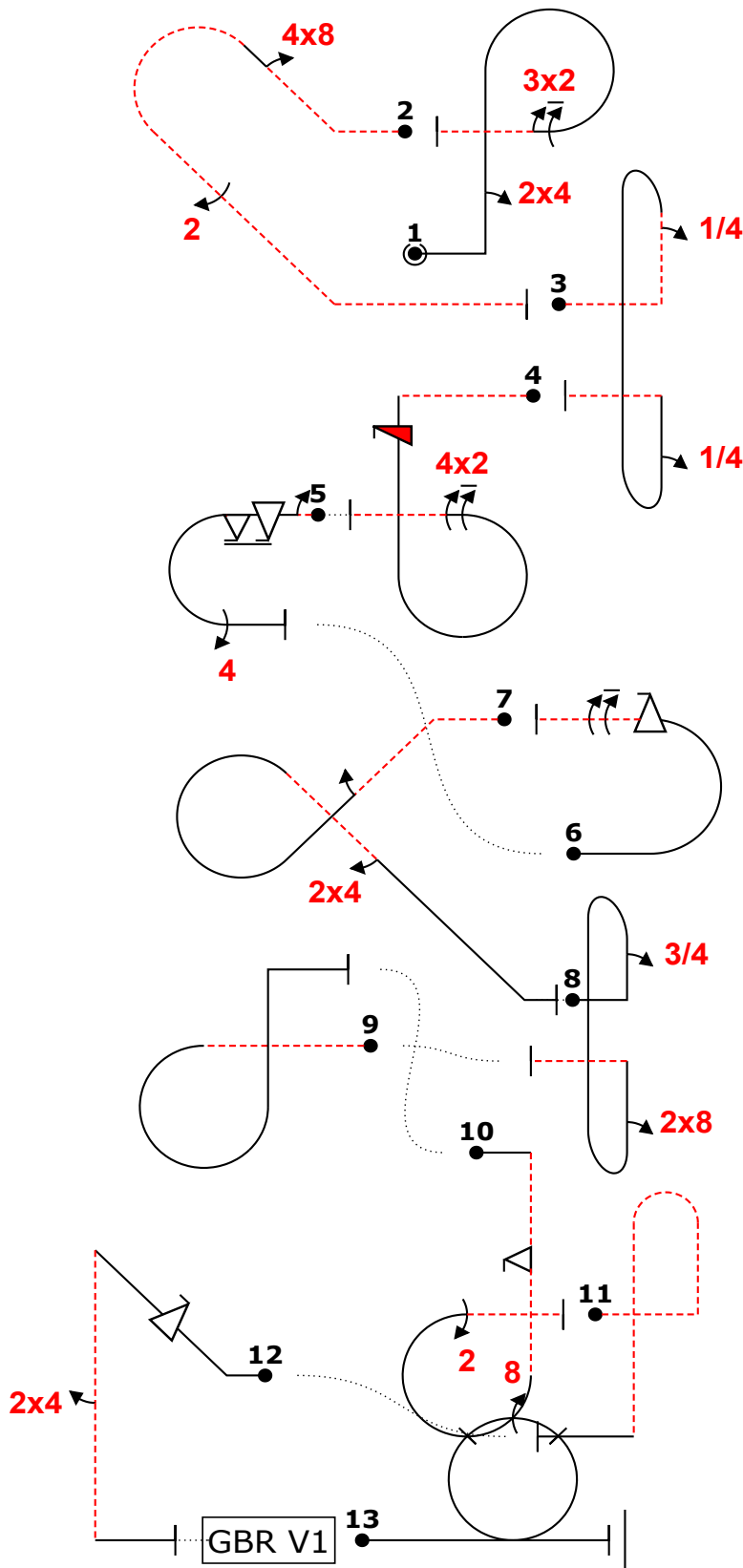
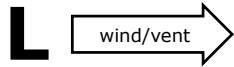

Fig	Grade	Pos	Remarks
1	.		
2	.		
3	.		
4	.		
5	.		
6	.		
7	.		
8	.		
9	.		
10	.		
11	.		
12	.		
13	.		

Positioning
30 .

Too Low		Trg Violation	
Too High		Wing Rocks	
Interruptions		Disqual Fig	
Insertions		Other(note...)	

Fig 1 G	K	Fig 2 A	K	Fig 3 L	K	Fig 4 F	K	Fig 5 B	K	Fig 6 C	K	Fig 7 I	K	Fig 8 H	K	Fig 9 L	K	Fig 10 D	K	Fig 11 L	K	Fig 12 E	K	Fig 13 J	K
8.6.2.1	12	8.4.15.2	16	8.8.8.2	20	8.6.1.4	12	7.2.1.4	6	7.2.1.1	6	7.3.4.4	15	8.8.1.1	18	8.6.6.4	13	8.6.3.3	13	8.4.2.2	17	1.2.1.1	13	7.4.1.1	10
9.4.1.2	9	9.8.2.2	9	9.1.1.1	6	9.12.1.4	7	9.1.3.2	4	9.9.3.4	11	9.1.4.2	4	9.1.1.3	10			9.9.10.2	13			9.9.2.4	13	9.8.3.4	15
9.2.3.6	12	9.2.4.4	9	9.1.1.1	6	9.2.3.8	15	9.9.3.6	14	9.1.3.8	12	9.4.4.2	5	9.8.1.1	7			9.2.3.4	9			9.4.5.2	5		
	33		34		8		34		35		29		24		35		8		35		8		31		25

Pilot:

A/C:



← wind/vent **R**

Figure K
339
 Total K
369

Judges Name
 Signature Number

Flight #
G

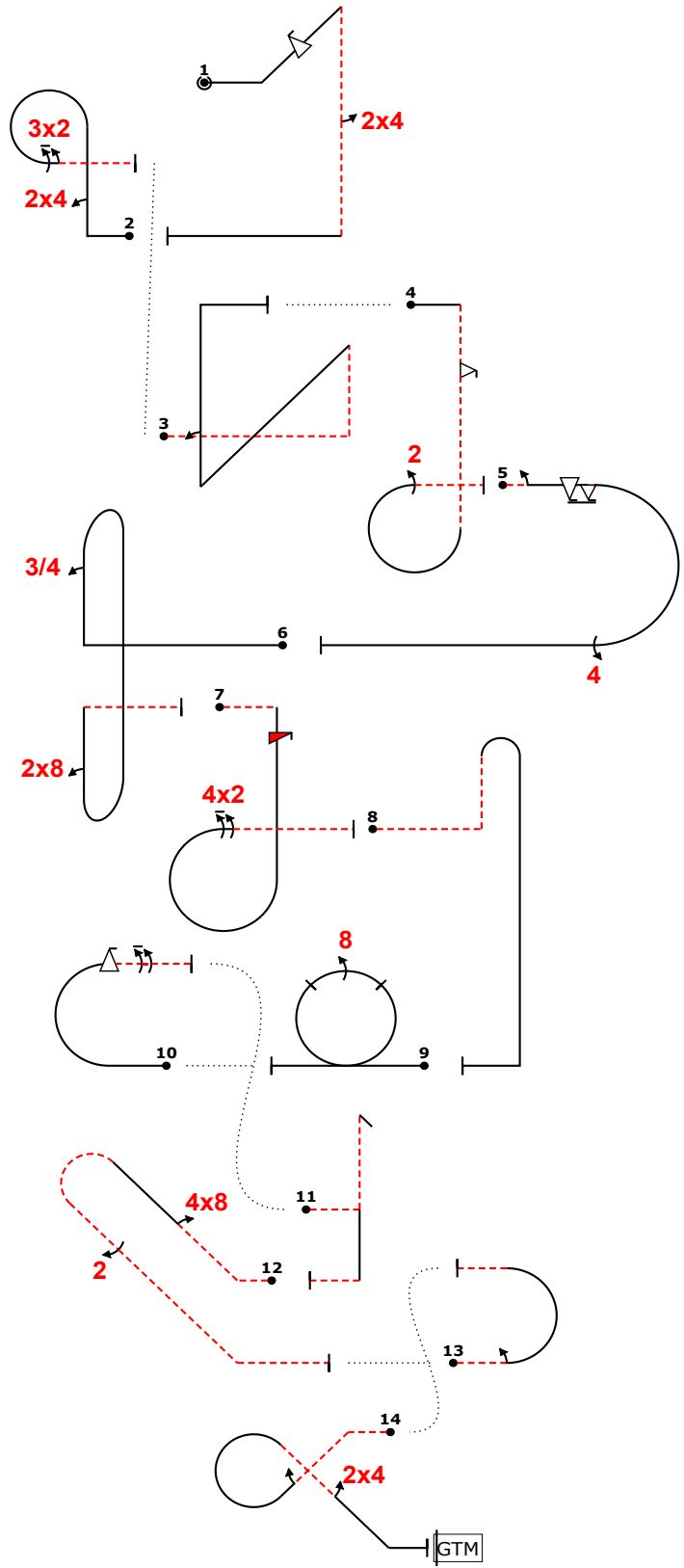

Fig	Grade	Pos	Remarks
1	.		
2	.		
3	.		
4	.		
5	.		
6	.		
7	.		
8	.		
9	.		
10	.		
11	.		
12	.		
13	.		
14	.		

Positioning
30 .

Too Low		Trg Violation	
Too High		Wing Rocks	
Interruptions		Disqual Fig	
Insertions		Other(note...)	

Fig 1 E	K	Fig 2 G	K	Fig 3 L	K	Fig 4 D	K	Fig 5 B	K	Fig 6 H	K	Fig 7 F	K	Fig 8 L	K	Fig 9 J	K	Fig 10 C	K	Fig 11 L	K	Fig 12 A	K	Fig 13 L	K	Fig 14 I	K
1.2.1.1	13	8.6.2.1	12	1.3.10.2	24	8.6.3.3	13	7.2.1.4	6	8.8.1.1	18	8.6.1.4	12	8.4.4.2	14	7.4.1.1	10	7.2.1.1	6	5.2.1.2	23	8.4.15.2	16	7.2.3.2	7	7.3.4.4	15
9.9.2.4	13	9.4.1.2	9	9.1.1.2	8	9.9.10.2	13	9.1.3.2	4	9.1.1.3	10	9.12.1.4	7			9.8.3.4	15	9.9.3.4	11			9.8.2.2	9	9.1.3.2	4	9.1.4.2	4
9.4.5.2	5	9.2.3.6	12			9.2.3.4	9	9.9.3.6	14	9.8.1.1	7	9.2.3.8	15					9.1.3.8	12			9.2.4.4	9			9.4.4.2	5
	31		33		6		35		35		35		34		6		25		29		6		34		6		24



Figure K
 339
 Total K
 369

Judges Name	
Signature	Number

Flight #
G

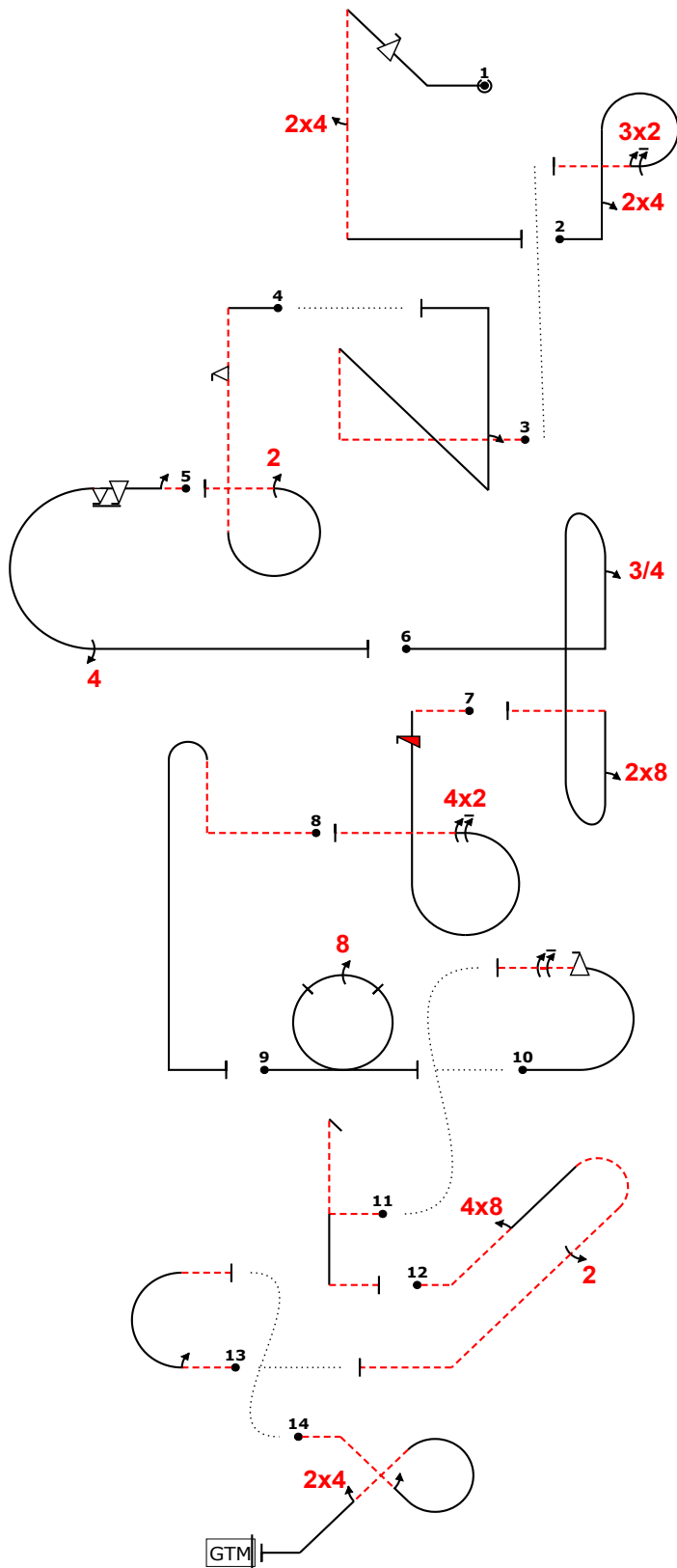
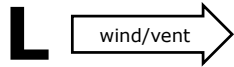

Fig	Grade	Pos	Remarks
1	.		
2	.		
3	.		
4	.		
5	.		
6	.		
7	.		
8	.		
9	.		
10	.		
11	.		
12	.		
13	.		
14	.		

Positioning
 30

Too Low		Trg Violation	
Too High		Wing Rocks	
Interruptions		Disqual Fig	
Insertions		Other(note...)	

Fig 1 E	K	Fig 2 G	K	Fig 3 L	K	Fig 4 D	K	Fig 5 B	K	Fig 6 H	K	Fig 7 F	K	Fig 8 L	K	Fig 9 J	K	Fig 10 C	K	Fig 11 L	K	Fig 12 A	K	Fig 13 L	K	Fig 14 I	K
1.2.1.1	13	8.6.2.1	12	1.3.10.2	24	8.6.3.3	13	7.2.1.4	6	8.8.1.1	18	8.6.1.4	12	8.4.4.2	14	7.4.1.1	10	7.2.1.1	6	5.2.1.2	23	8.4.15.2	16	7.2.3.2	7	7.3.4.4	15
9.9.2.4	13	9.4.1.2	9	9.1.1.2	8	9.9.10.2	13	9.1.3.2	4	9.1.1.3	10	9.12.1.4	7			9.8.3.4	15	9.9.3.4	11			9.8.2.2	9	9.1.3.2	4	9.1.4.2	4
9.4.5.2	5	9.2.3.6	12			9.2.3.4	9	9.9.3.6	14	9.8.1.1	7	9.2.3.8	15					9.1.3.8	12			9.2.4.4	9			9.4.4.2	5
	31		33		6		35		35		35		34		6		25		29		6		34		6		24

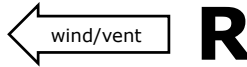

Figure K
339
 Total K
369

Judges Name	
Signature	Number

Flight #
H

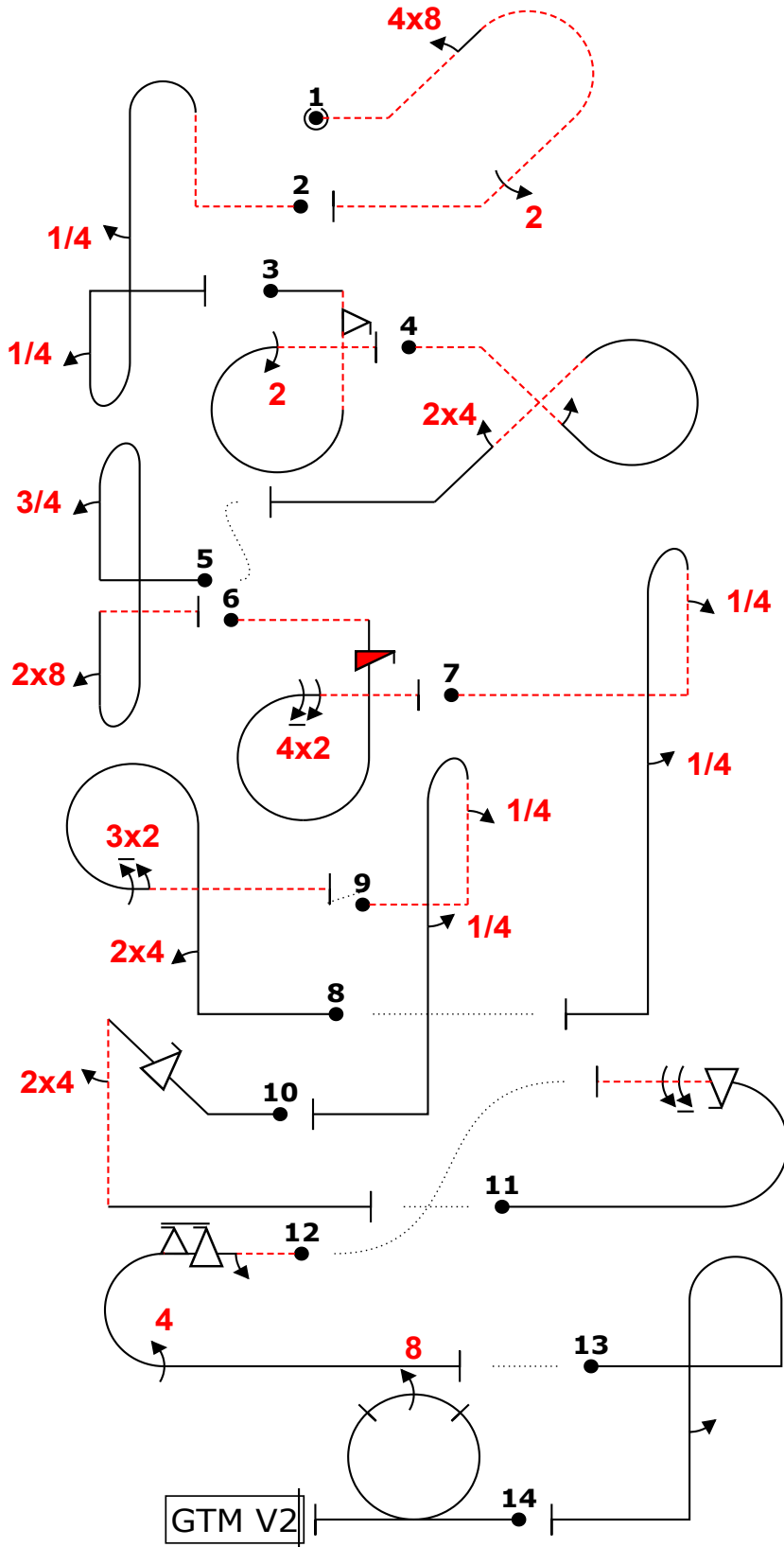

Fig	Grade	Pos	Remarks
1	.		
2	.		
3	.		
4	.		
5	.		
6	.		
7	.		
8	.		
9	.		
10	.		
11	.		
12	.		
13	.		
14	.		

Positioning
30

Too Low		Trg Violation	
Too High		Wing Rocks	
Interruptions		Disqual Fig	
Insertions		Other(note...)	

Fig 1 A	K	Fig 2 L	K	Fig 3 D	K	Fig 4 I	K	Fig 5 H	K	Fig 6 F	K	Fig 7 L	K	Fig 8 G	K	Fig 9 L	K	Fig 10 E	K	Fig 11 C	K	Fig 12 B	K	Fig 13 L	K	Fig 14 J	K
8.4.15.2	16	8.8.7.2	21	8.6.3.3	13	7.3.4.4	15	8.8.1.1	18	8.6.1.4	12	8.4.4.2	14	8.6.2.1	12	8.4.4.2	14	1.2.1.1	13	7.2.1.1	6	7.2.1.4	6	8.4.1.1	13	7.4.1.1	10
9.8.2.2	9	9.1.5.1	2	9.9.10.2	13	9.1.4.2	4	9.1.1.3	10	9.12.1.4	7	9.1.1.1	6	9.4.1.2	9	9.1.1.1	6	9.9.2.4	13	9.9.3.4	11	9.1.3.2	4	9.1.5.2	4	9.8.3.4	15
9.2.4.4	9	9.1.1.1	6	9.2.3.4	9	9.4.4.2	5	9.8.1.1	7	9.2.3.8	15	9.1.5.1	2	9.2.3.6	12	9.1.5.1	2	9.4.5.2	5	9.1.3.8	12	9.9.3.6	14				
	34		6		35		24		35		34		6		33		6		31		29		35		6		25

Pilot:

A/C:



Figure K
339
 Total K
369

Judges Name	
Signature	Number

Flight #
H

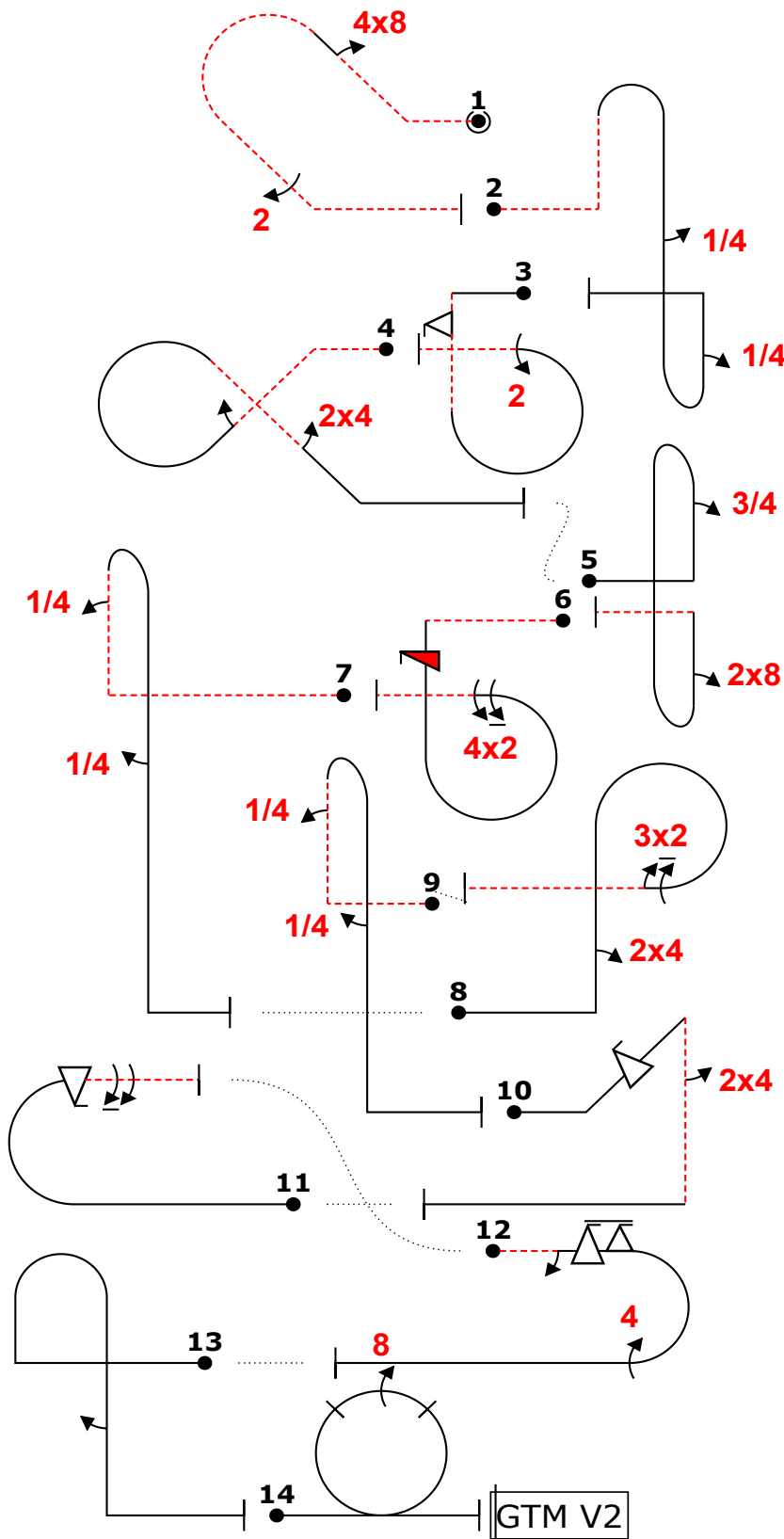
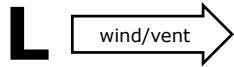

Fig	Grade	Pos	Remarks
1	.		
2	.		
3	.		
4	.		
5	.		
6	.		
7	.		
8	.		
9	.		
10	.		
11	.		
12	.		
13	.		
14	.		

Positioning
30

Too Low		Trg Violation	
Too High		Wing Rocks	
Interruptions		Disqual Fig	
Insertions		Other(note...)	

Fig 1 A	K	Fig 2 L	K	Fig 3 D	K	Fig 4 I	K	Fig 5 H	K	Fig 6 F	K	Fig 7 L	K	Fig 8 G	K	Fig 9 L	K	Fig 10 E	K	Fig 11 C	K	Fig 12 B	K	Fig 13 L	K	Fig 14 J	K
8.4.15.2	16	8.8.7.2	21	8.6.3.3	13	7.3.4.4	15	8.8.1.1	18	8.6.1.4	12	8.4.4.2	14	8.6.2.1	12	8.4.4.2	14	1.2.1.1	13	7.2.1.1	6	7.2.1.4	6	8.4.1.1	13	7.4.1.1	10
9.8.2.2	9	9.1.5.1	2	9.9.10.2	13	9.1.4.2	4	9.1.1.3	10	9.12.1.4	7	9.1.1.1	6	9.4.1.2	9	9.1.1.1	6	9.9.2.4	13	9.9.3.4	11	9.1.3.2	4	9.1.5.2	4	9.8.3.4	15
9.2.4.4	9	9.1.1.1	6	9.2.3.4	9	9.4.4.2	5	9.8.1.1	7	9.2.3.8	15	9.1.5.1	2	9.2.3.6	12	9.1.5.1	2	9.4.5.2	5	9.1.3.8	12	9.9.3.6	14				
	34		6		35		24		35		34		6		33		6		31		29		35		6		25

Pilot:

A/C:



Figure K
 339
 Total K
 369

Judges Name	
Signature	Number

Flight #
I

wind/vent **R**

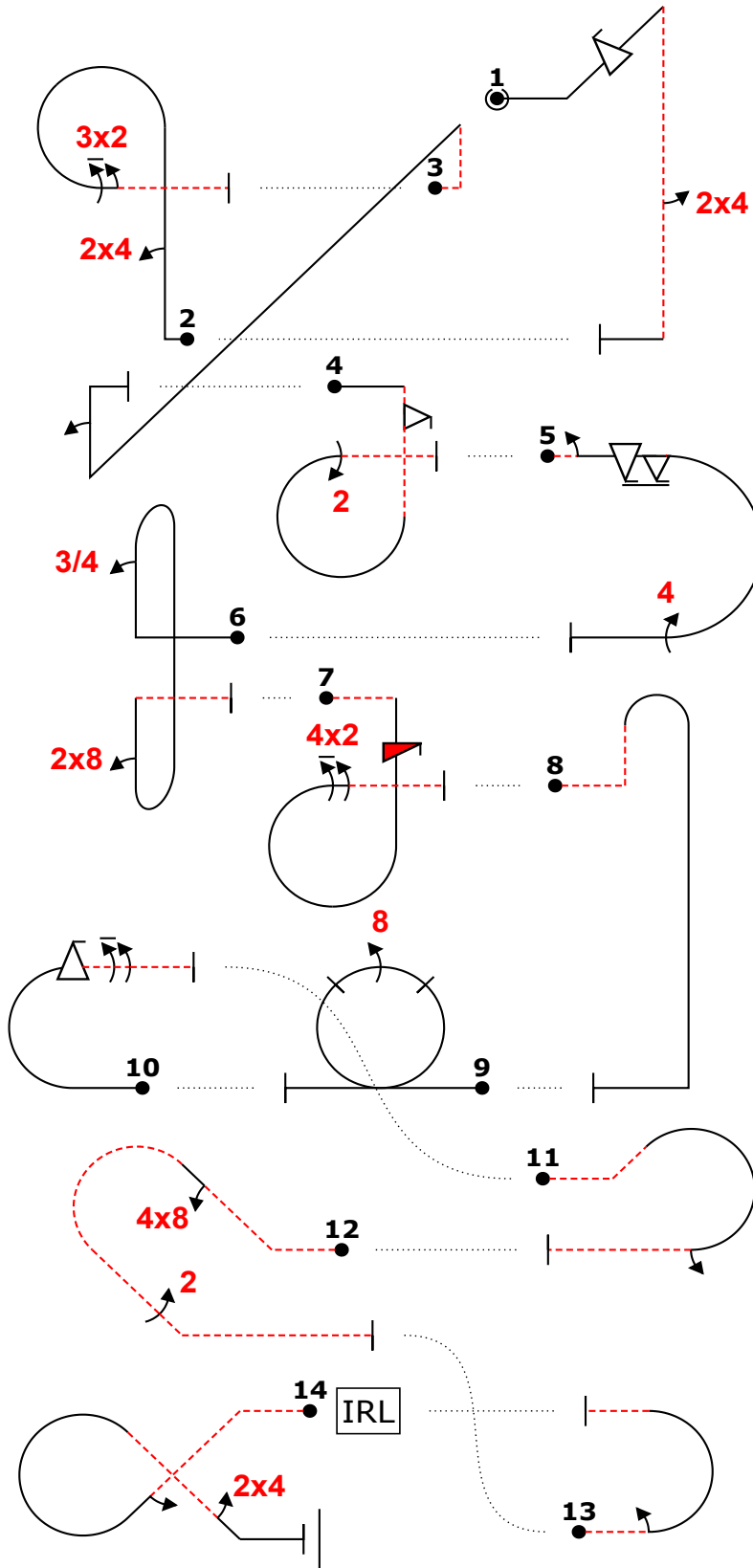

Fig	Grade	Pos	Remarks
1	.		
2	.		
3	.		
4	.		
5	.		
6	.		
7	.		
8	.		
9	.		
10	.		
11	.		
12	.		
13	.		
14	.		

Positioning
 30

Too Low		Trg Violation	
Too High		Wing Rocks	
Interruptions		Disqual Fig	
Insertions		Other(note...)	

Fig 1 E	K	Fig 2 G	K	Fig 3 L	K	Fig 4 D	K	Fig 5 B	K	Fig 6 H	K	Fig 7 F	K	Fig 8 L	K	Fig 9 J	K	Fig 10 C	K	Fig 11 L	K	Fig 12 A	K	Fig 13 L	K	Fig 14 I	K		
1.2.1.1	13	8.6.2.1	12	1.3.10.2	24	8.6.3.3	13	7.2.1.4	6	8.8.1.1	18	8.6.1.4	12	8.4.4.2	14	7.4.1.1	10	7.2.1.1	6	8.5.3.2	11	8.4.15.2	16	7.2.3.2	7	7.3.4.4	15		
9.9.2.4	13	9.4.1.2	9	9.1.1.2	8	9.9.10.2	13	9.1.3.2	4	9.1.1.3	10	9.12.1.4	7	9.8.3.4	15	9.9.3.4	11	9.1.3.2	4	9.8.2.2	9	9.1.3.2	4	9.1.4.2	4	9.1.4.2	4	9.4.4.2	5
9.4.5.2	5	9.2.3.6	12			9.2.3.4	9	9.9.3.6	14	9.8.1.1	7	9.2.3.8	15			9.1.3.8	12			9.2.4.4	9								
	31		33		6		35		35		35		34		6		25		29		6		34		6		24		

Pilot:

A/C:



Figure K
 339
 Total K
 369

Judges Name	
Signature	Number

Flight # I

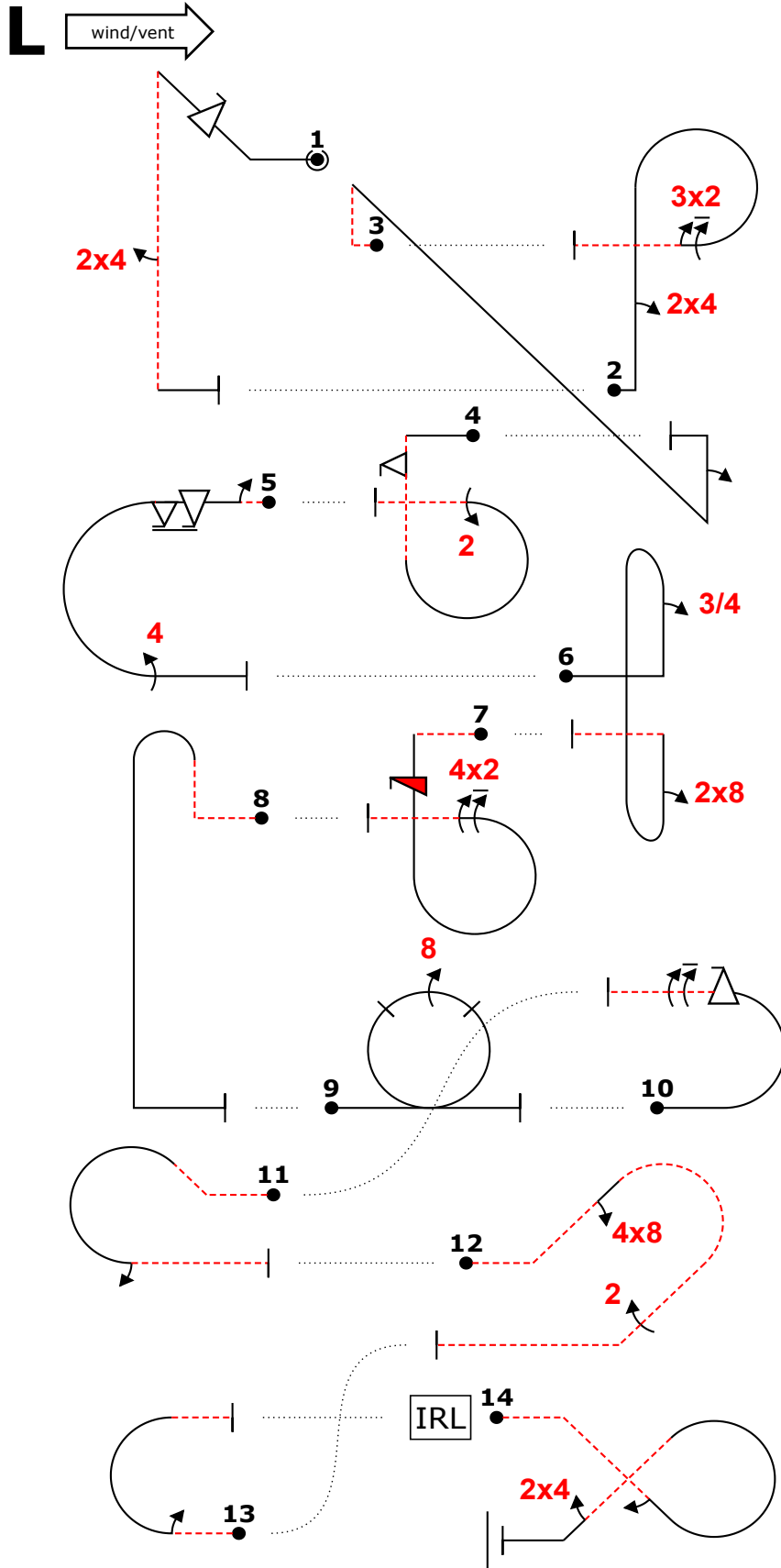

Fig	Grade	Pos	Remarks
1	.		
2	.		
3	.		
4	.		
5	.		
6	.		
7	.		
8	.		
9	.		
10	.		
11	.		
12	.		
13	.		
14	.		

Positioning
 30

Too Low		Trg Violation	
Too High		Wing Rocks	
Interruptions		Disqual Fig	
Insertions		Other(note...)	

Fig	E	K	Fig	G	K	Fig	L	K	Fig	D	K	Fig	B	K	Fig	H	K	Fig	F	K	Fig	L	K	Fig	J	K	Fig	C	K	Fig	L	K	Fig	A	K	Fig	L	K	Fig	I	K										
1.2.1.1	13	8.6.2.1	12	1.3.10.2	24	8.6.3.3	13	7.2.1.4	6	8.8.1.1	18	8.6.1.4	12	8.4.4.2	14	7.4.1.1	10	7.2.1.1	6	8.5.3.2	11	8.4.15.2	16	7.2.3.2	7	7.3.4.4	15	9.9.2.4	13	9.4.1.2	9	9.1.1.2	8	9.9.10.2	13	9.1.3.2	4	9.1.1.3	10	9.12.1.4	7	9.9.3.4	11	9.1.3.2	4	9.8.2.2	9	9.1.3.2	4	9.1.4.2	4
9.4.5.2	5	9.2.3.6	12			9.2.3.4	9	9.9.3.6	14	9.8.1.1	7	9.2.3.8	15			9.1.3.8	12			9.2.4.4	9					9.4.4.2	5																								
	31		33		6		35		35		35		34		6		25		29		6		34		6		24																								

Pilot:

A/C:

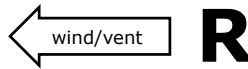

Figure K
339
 Total K
369

Judges Name	
Signature	Number

Flight #
J

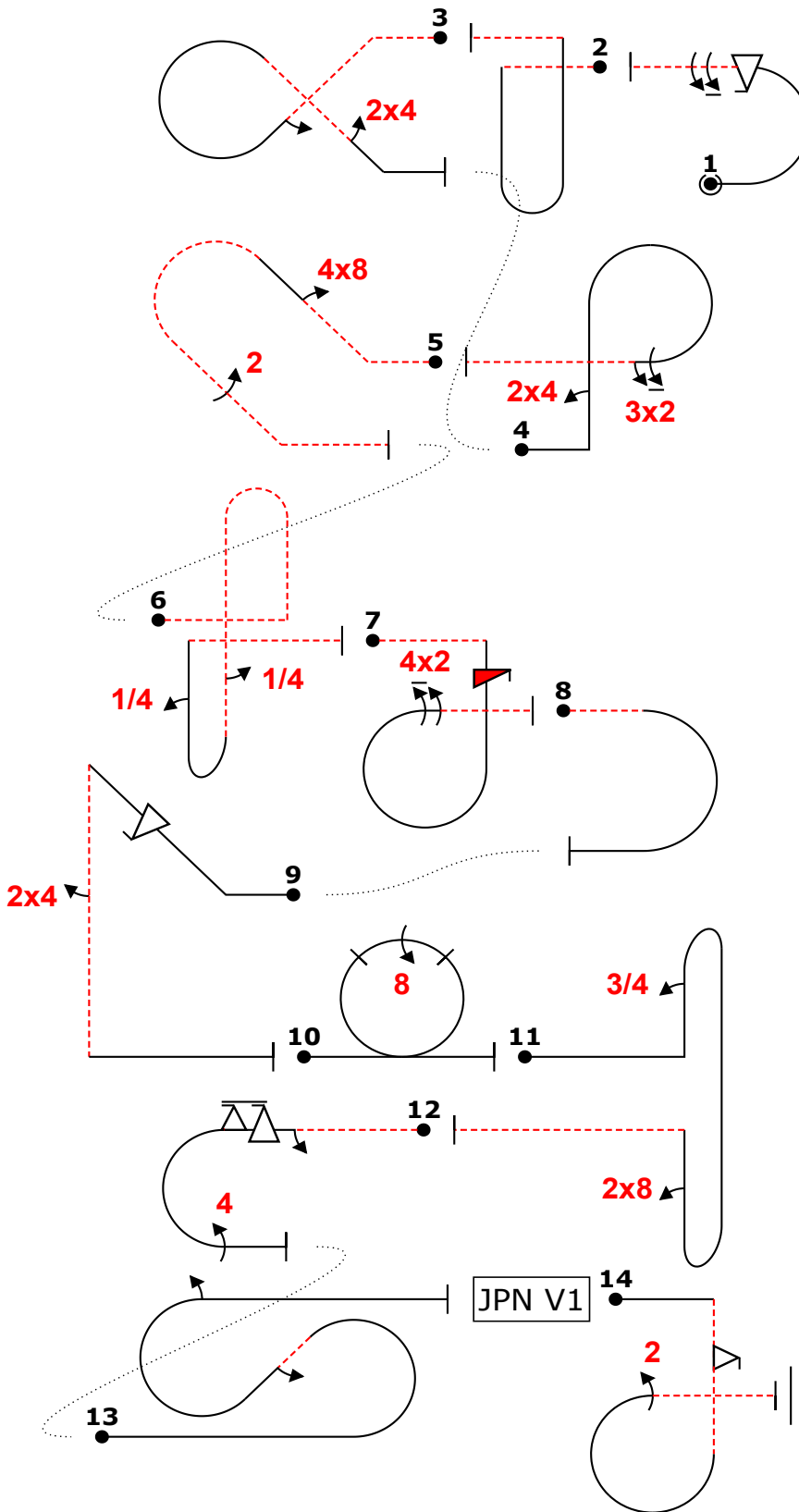

Fig	Grade	Pos	Remarks
1	.		
2	.		
3	.		
4	.		
5	.		
6	.		
7	.		
8	.		
9	.		
10	.		
11	.		
12	.		
13	.		
14	.		

Positioning
30

Too Low		Trg Violation	
Too High		Wing Rocks	
Interruptions		Disqual Fig	
Insertions		Other(note...)	

Fig 1 C	K	Fig 2 L	K	Fig 3 I	K	Fig 4 G	K	Fig 5 A	K	Fig 6 L	K	Fig 7 F	K	Fig 8 L	K	Fig 9 E	K	Fig 10 J	K	Fig 11 H	K	Fig 12 B	K	Fig 13 L	K	Fig 14 D	K
7.2.1.1	6	8.4.1.4	13	7.3.4.4	15	8.6.2.1	12	8.4.15.2	16	8.8.4.2	22	8.6.1.4	12	7.2.1.4	6	1.2.1.1	13	7.4.1.1	10	8.8.1.1	18	7.2.1.4	6	7.5.7.1	15	8.6.3.3	13
9.9.3.4	11			9.1.4.2	4	9.4.1.2	9	9.8.2.2	9	9.1.5.1	2	9.12.1.4	7			9.9.2.4	13	9.8.3.4	15	9.1.1.3	10	9.1.3.2	4	9.1.4.2	4	9.9.10.2	13
9.1.3.8	12			9.4.4.2	5	9.2.3.6	12	9.2.4.4	9	9.1.1.1	6	9.2.3.8	15			9.4.5.2	5			9.8.1.1	7	9.9.3.6	14	9.1.3.2	4	9.2.3.4	9
	29		6		24		33		34		6		34		6		31		25		35		35		6		35

Pilot:

A/C:

Team: **JPN**



Figure K
339
 Total K
369

Judges Name	
Signature	Number

Flight #
J

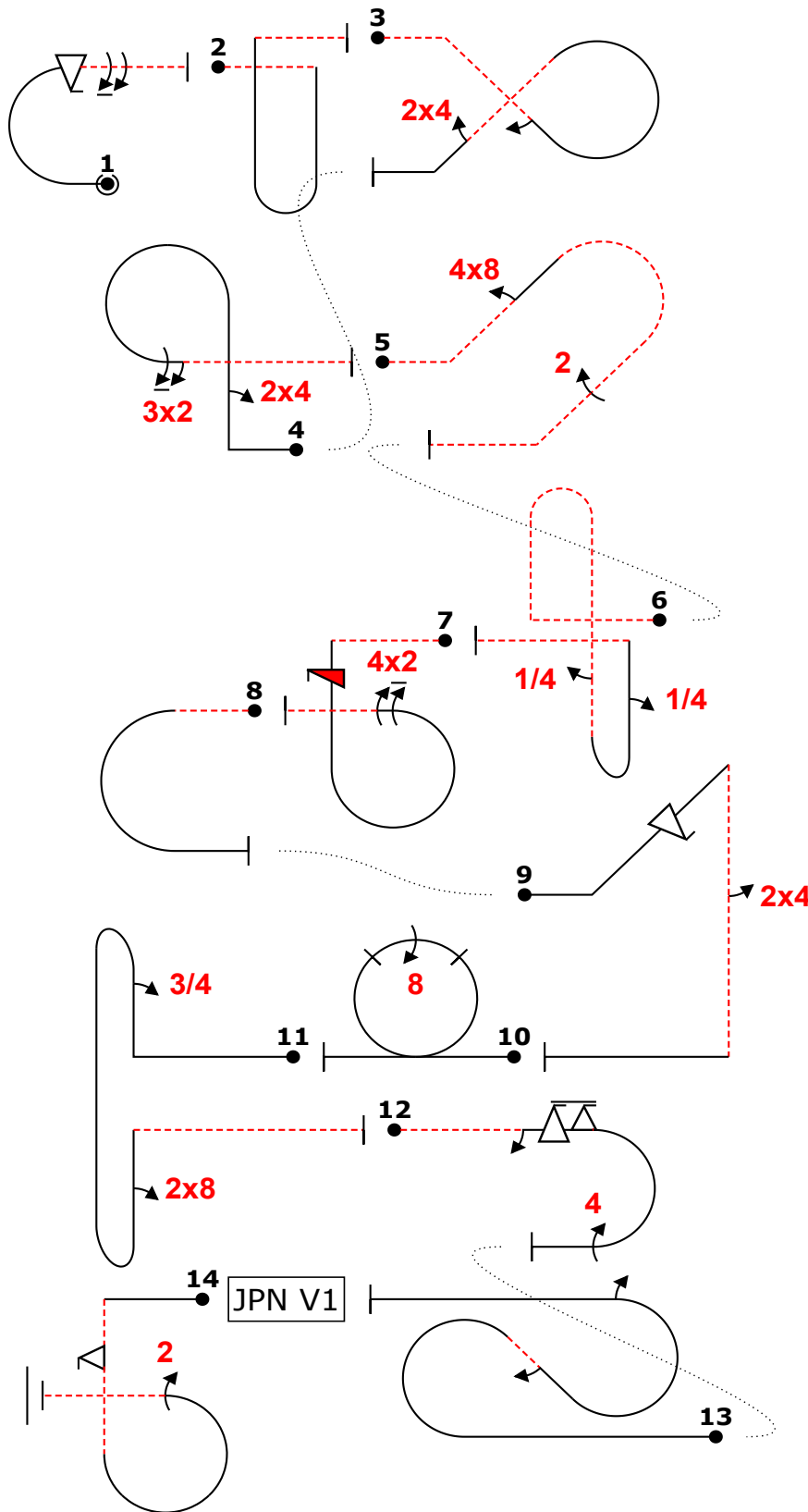
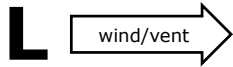

Fig	Grade	Pos	Remarks
1	.		
2	.		
3	.		
4	.		
5	.		
6	.		
7	.		
8	.		
9	.		
10	.		
11	.		
12	.		
13	.		
14	.		

Positioning
30

Too Low		Trg Violation	
Too High		Wing Rocks	
Interruptions		Disqual Fig	
Insertions		Other(note...)	

Fig 1 C	K	Fig 2 L	K	Fig 3 I	K	Fig 4 G	K	Fig 5 A	K	Fig 6 L	K	Fig 7 F	K	Fig 8 L	K	Fig 9 E	K	Fig 10 J	K	Fig 11 H	K	Fig 12 B	K	Fig 13 L	K	Fig 14 D	K
7.2.1.1	6	8.4.1.4	13	7.3.4.4	15	8.6.2.1	12	8.4.15.2	16	8.8.4.2	22	8.6.1.4	12	7.2.1.4	6	1.2.1.1	13	7.4.1.1	10	8.8.1.1	18	7.2.1.4	6	7.5.7.1	15	8.6.3.3	13
9.9.3.4	11			9.1.4.2	4	9.4.1.2	9	9.8.2.2	9	9.1.5.1	2	9.12.1.4	7			9.9.2.4	13	9.8.3.4	15	9.1.1.3	10	9.1.3.2	4	9.1.4.2	4	9.9.10.2	13
9.1.3.8	12			9.4.4.2	5	9.2.3.6	12	9.2.4.4	9	9.1.1.1	6	9.2.3.8	15			9.4.5.2	5			9.8.1.1	7	9.9.3.6	14	9.1.3.2	4	9.2.3.4	9
	29		6		24		33		34		6		34		6		31		25		35		35		6		35

Pilot:

A/C:

Team: **JPN**

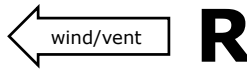

Figure K
339
 Total K
369

Judges Name	
Signature	Number

Flight # K

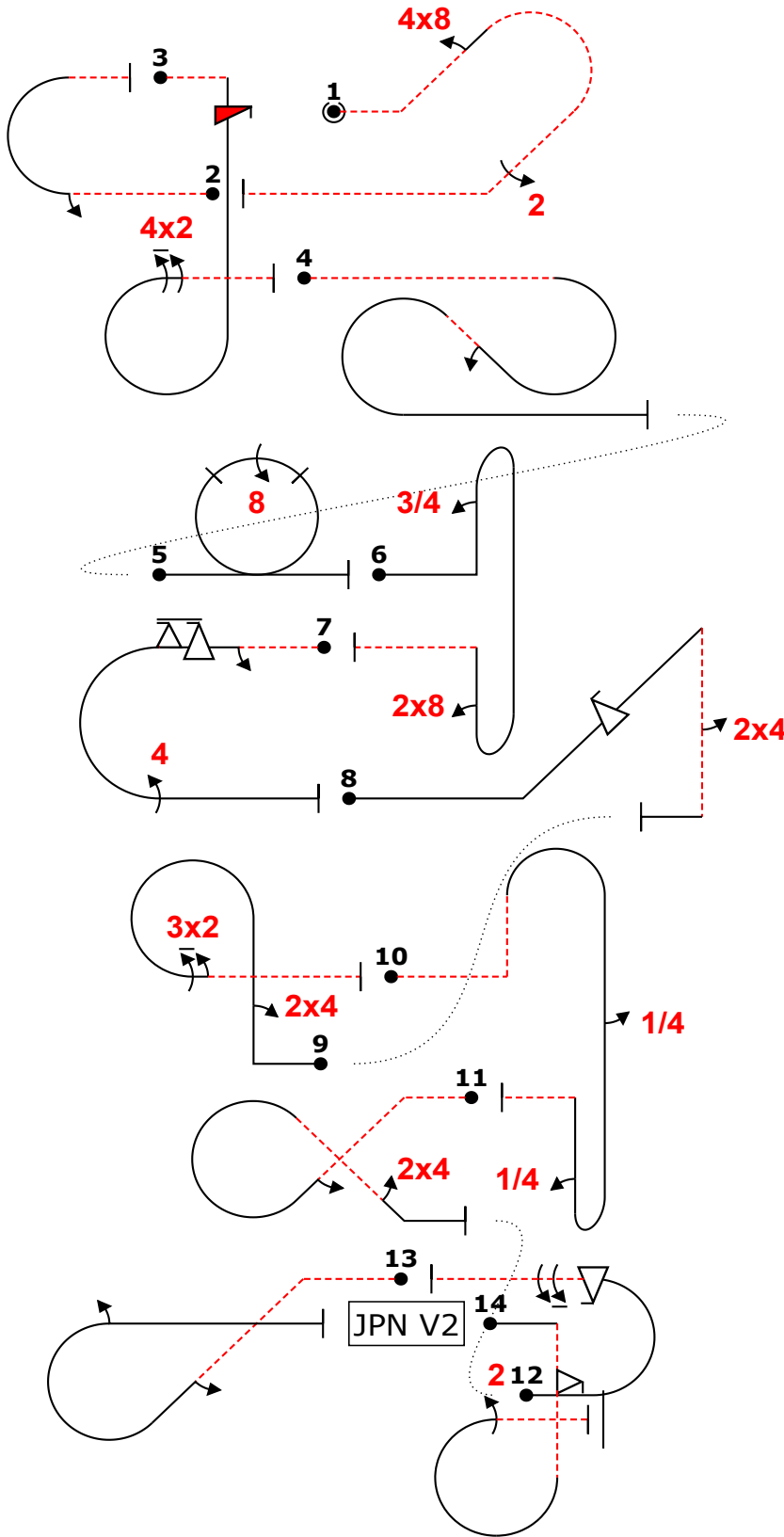

Fig	Grade	Pos	Remarks
1	.		
2	.		
3	.		
4	.		
5	.		
6	.		
7	.		
8	.		
9	.		
10	.		
11	.		
12	.		
13	.		
14	.		

Positioning
30

Too Low		Trg Violation	
Too High		Wing Rocks	
Interruptions		Disqual Fig	
Insertions		Other(note...)	

Fig 1 A	K	Fig 2 L	K	Fig 3 F	K	Fig 4 L	K	Fig 5 J	K	Fig 6 H	K	Fig 7 B	K	Fig 8 E	K	Fig 9 G	K	Fig 10 L	K	Fig 11 I	K	Fig 12 C	K	Fig 13 L	K	Fig 14 D	K
8.4.15.2	16	7.2.3.2	7	8.6.1.4	12	7.5.2.4	15	7.4.1.1	10	8.8.1.1	18	7.2.1.4	6	1.2.1.1	13	8.6.2.1	12	8.8.8.2	20	7.3.4.4	15	7.2.1.1	6	8.5.4.4	11	8.6.3.3	13
9.8.2.2	9	9.1.3.2	4	9.12.1.4	7	9.1.2.2	6	9.8.3.4	15	9.1.1.3	10	9.1.3.2	4	9.9.2.4	13	9.4.1.2	9	9.1.5.1	2	9.1.4.2	4	9.9.3.4	11	9.1.4.2	4	9.9.10.2	13
9.2.4.4	9			9.2.3.8	15					9.8.1.1	7	9.9.3.6	14	9.4.5.2	5	9.2.3.6	12	9.1.1.1	6	9.4.4.2	5	9.1.3.8	12	9.1.3.2	4	9.2.3.4	9
	34		6		34		6		25		35		35		31		33		6		24		29		6		35

Pilot:

A/C:



Figure K
339
 Total K
369

Judges Name	
Signature	Number

Flight #
K

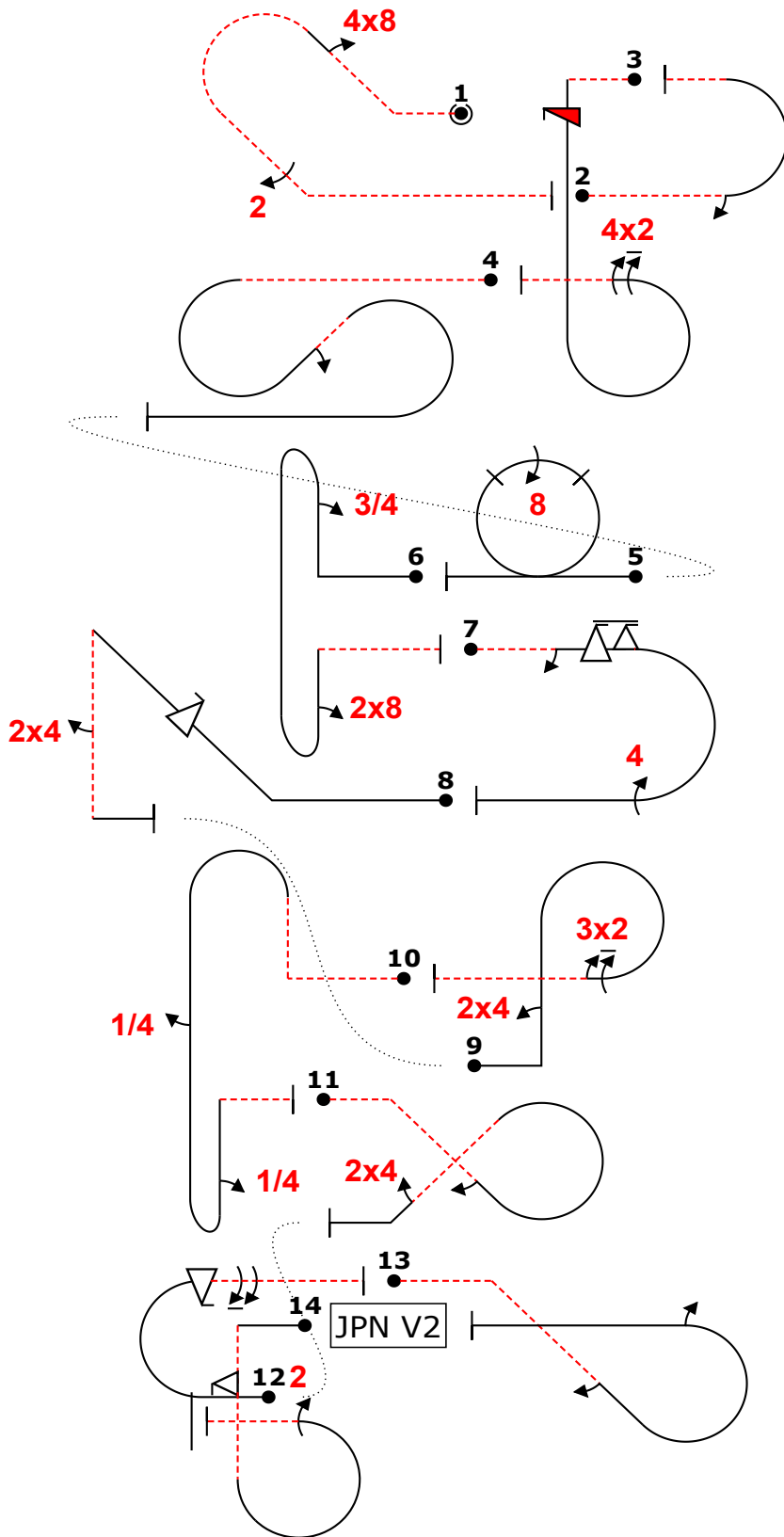
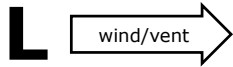

Fig	Grade	Pos	Remarks
1	.		
2	.		
3	.		
4	.		
5	.		
6	.		
7	.		
8	.		
9	.		
10	.		
11	.		
12	.		
13	.		
14	.		

Positioning
30

Too Low		Trg Violation	
Too High		Wing Rocks	
Interruptions		Disqual Fig	
Insertions		Other(note...)	

Fig 1 A	K	Fig 2 L	K	Fig 3 F	K	Fig 4 L	K	Fig 5 J	K	Fig 6 H	K	Fig 7 B	K	Fig 8 E	K	Fig 9 G	K	Fig 10 L	K	Fig 11 I	K	Fig 12 C	K	Fig 13 L	K	Fig 14 D	K
8.4.15.2	16	7.2.3.2	7	8.6.1.4	12	7.5.2.4	15	7.4.1.1	10	8.8.1.1	18	7.2.1.4	6	1.2.1.1	13	8.6.2.1	12	8.8.8.2	20	7.3.4.4	15	7.2.1.1	6	8.5.4.4	11	8.6.3.3	13
9.8.2.2	9	9.1.3.2	4	9.12.1.4	7	9.1.2.2	6	9.8.3.4	15	9.1.1.3	10	9.1.3.2	4	9.9.2.4	13	9.4.1.2	9	9.1.5.1	2	9.1.4.2	4	9.9.3.4	11	9.1.4.2	4	9.9.10.2	13
9.2.4.4	9			9.2.3.8	15			9.8.1.1	7	9.9.3.6	14	9.4.5.2	5	9.2.3.6	12	9.1.1.1	6	9.4.4.2	5	9.1.3.8	12	9.1.3.2	4	9.2.3.4	9		
	34		6		34		6		25		35		35		31		33		6		24		29		6		35

Pilot:

A/C:



Figure K
 339
 Total K
 369

Judges Name	
Signature	Number

Flight #
 L

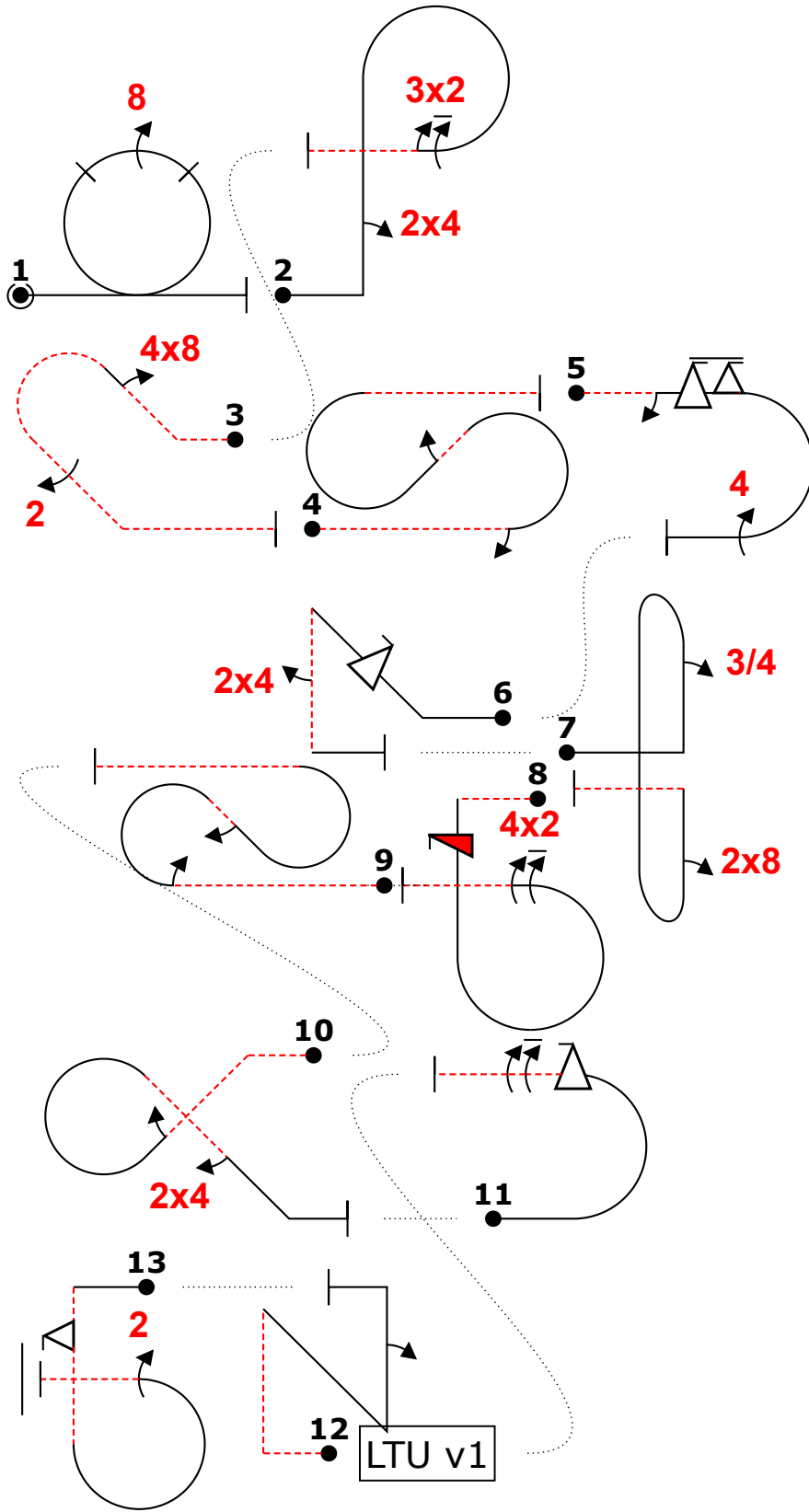
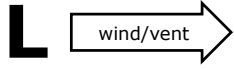

Fig	Grade	Pos	Remarks
1	.		
2	.		
3	.		
4	.		
5	.		
6	.		
7	.		
8	.		
9	.		
10	.		
11	.		
12	.		
13	.		

Positioning
 30

Too Low		Trg Violation	
Too High		Wing Rocks	
Interruptions		Disqual Fig	
Insertions		Other(note...)	

Fig 1 J	K	Fig 2 G	K	Fig 3 A	K	Fig 4 L	K	Fig 5 B	K	Fig 6 E	K	Fig 7 H	K	Fig 8 F	K	Fig 9 L	K	Fig 10 I	K	Fig 11 C	K	Fig 12 L	K	Fig 13	K
7.4.1.1	10	8.6.2.1	12	8.4.15.2	16	7.5.5.2	15	7.2.1.4	6	1.2.1.1	13	8.8.1.1	18	8.6.1.4	12	7.5.5.2	15	7.3.4.4	15	7.2.1.1	6	1.3.10.2	24	8.6.3.3	13
9.8.3.4	15	9.4.1.2	9	9.8.2.2	9	9.1.3.2	4	9.1.3.2	4	9.9.2.4	13	9.1.1.3	10	9.12.1.4	7	9.1.3.2	4	9.1.4.2	4	9.9.3.4	11	9.1.1.2	8	9.9.10.2	13
		9.2.3.6	12	9.2.4.4	9	9.1.4.2	4	9.9.3.6	14	9.4.5.2	5	9.8.1.1	7	9.2.3.8	15	9.1.4.2	4	9.4.4.2	5	9.1.3.8	12			9.2.3.4	9
	25		33		34		8	9.4.3.4	11		31		35		34		8		24		29		8		35

Pilot:

A/C:

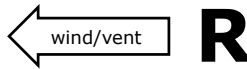

Figure K
339
 Total K
369

Judges Name	
Signature	Number

Flight # M

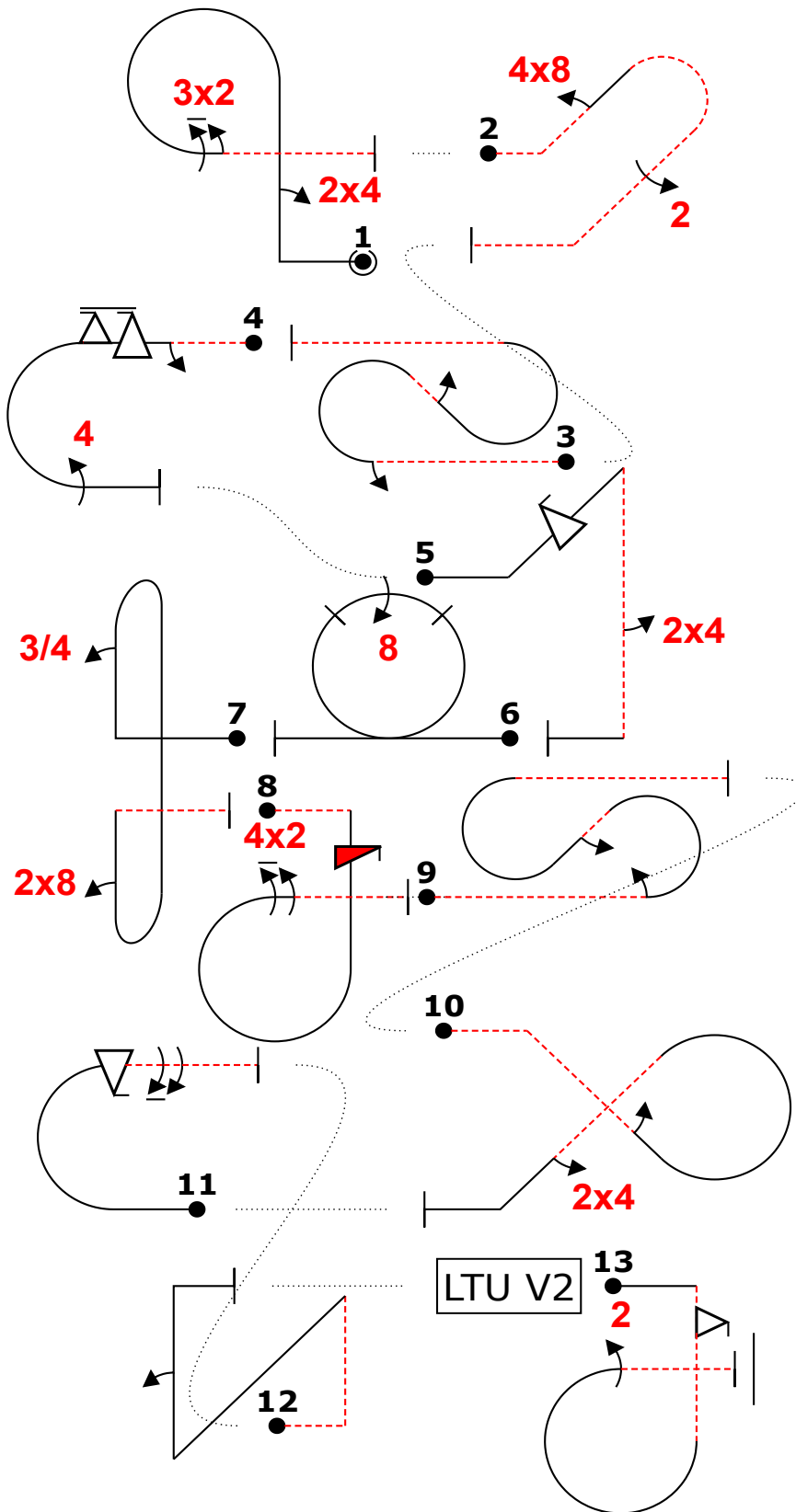

Fig	Grade	Pos	Remarks
1	.		
2	.		
3	.		
4	.		
5	.		
6	.		
7	.		
8	.		
9	.		
10	.		
11	.		
12	.		
13	.		

Positioning 30	.
--------------------------	---

Too Low		Trg Violation	
Too High		Wing Rocks	
Interruptions		Disqual Fig	
Insertions		Other(note...)	

Fig 1 G	K	Fig 2 A	K	Fig 3 L	K	Fig 4 B	K	Fig 5 E	K	Fig 6 J	K	Fig 7 H	K	Fig 8 F	K	Fig 9 L	K	Fig 10 I	K	Fig 11 C	K	Fig 12 L	K	Fig 13 D	K
8.6.2.1	12	8.4.15.2	16	7.5.5.2	15	7.2.1.4	6	1.2.1.1	13	7.4.1.1	10	8.8.1.1	18	8.6.1.4	12	7.5.5.2	15	7.3.4.4	15	7.2.1.1	6	1.3.10.2	24	8.6.3.3	13
9.4.1.2	9	9.8.2.2	9	9.1.3.2	4	9.1.3.2	4	9.9.2.4	13	9.8.3.4	15	9.1.1.3	10	9.12.1.4	7	9.1.3.2	4	9.1.4.2	4	9.9.3.4	11	9.1.1.2	8	9.9.10.2	13
9.2.3.6	12	9.2.4.4	9	9.1.4.2	4	9.9.3.6	14	9.4.5.2	5			9.8.1.1	7	9.2.3.8	15	9.1.4.2	4	9.4.4.2	5	9.1.3.8	12			9.2.3.4	9
	33		34		8		35		31		25		35		34		8		24		29		8		35

Pilot:

A/C:



Figure K
 339
 Total K
 369

Judges Name	
Signature	Number

Flight #
 M

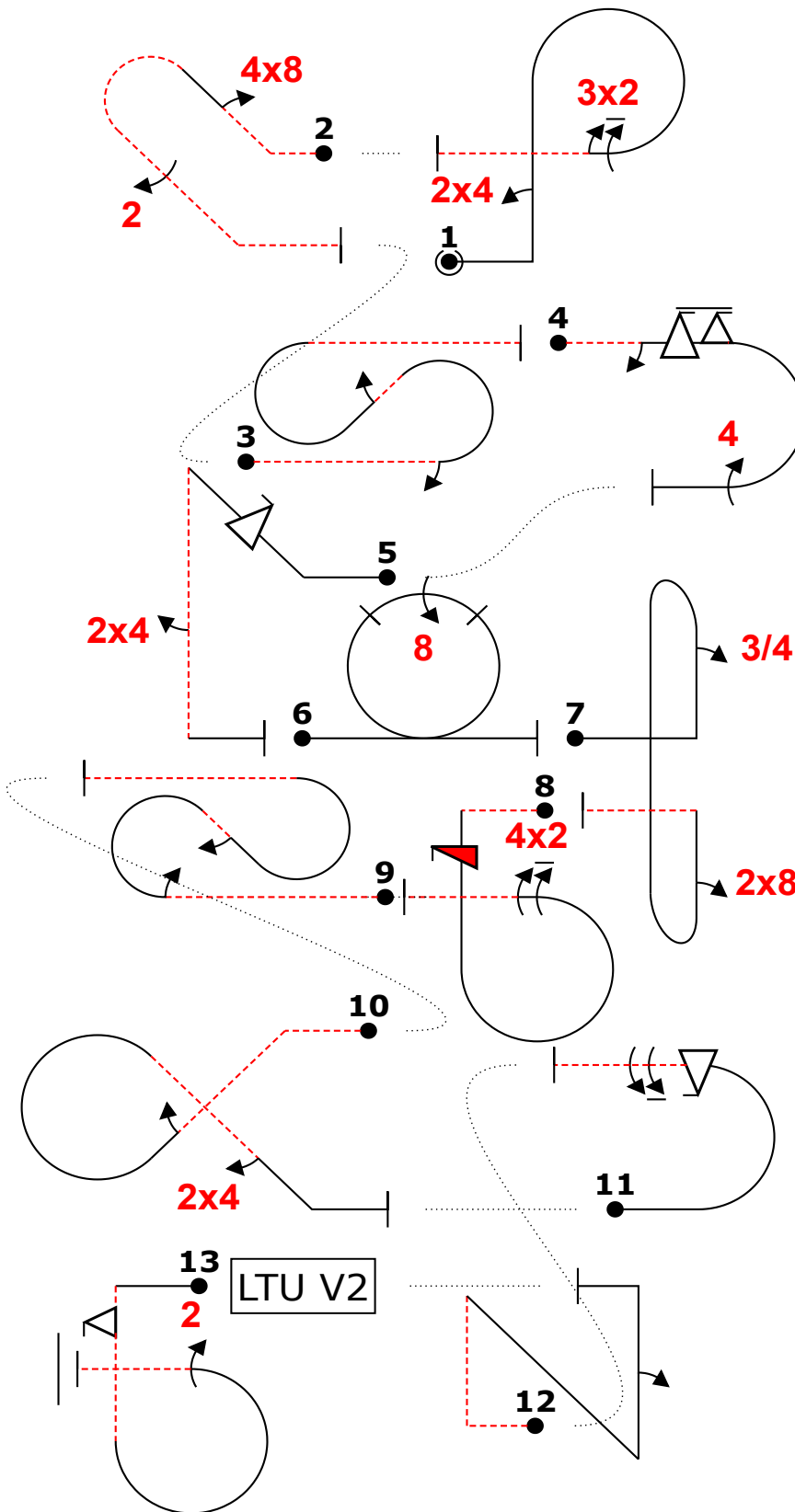
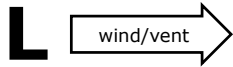

Fig	Grade	Pos	Remarks
1	.		
2	.		
3	.		
4	.		
5	.		
6	.		
7	.		
8	.		
9	.		
10	.		
11	.		
12	.		
13	.		

Positioning
 30 .

Too Low		Trg Violation	
Too High		Wing Rocks	
Interruptions		Disqual Fig	
Insertions		Other(note...)	

Fig 1 G	K	Fig 2 A	K	Fig 3 L	K	Fig 4 B	K	Fig 5 E	K	Fig 6 J	K	Fig 7 H	K	Fig 8 F	K	Fig 9 L	K	Fig 10 I	K	Fig 11 C	K	Fig 12 L	K	Fig 13 D	K
8.6.2.1	12	8.4.15.2	16	7.5.5.2	15	7.2.1.4	6	1.2.1.1	13	7.4.1.1	10	8.8.1.1	18	8.6.1.4	12	7.5.5.2	15	7.3.4.4	15	7.2.1.1	6	1.3.10.2	24	8.6.3.3	13
9.4.1.2	9	9.8.2.2	9	9.1.3.2	4	9.1.3.2	4	9.9.2.4	13	9.8.3.4	15	9.1.1.3	10	9.12.1.4	7	9.1.3.2	4	9.1.4.2	4	9.9.3.4	11	9.1.1.2	8	9.9.10.2	13
9.2.3.6	12	9.2.4.4	9	9.1.4.2	4	9.9.3.6	14	9.4.5.2	5			9.8.1.1	7	9.2.3.8	15	9.1.4.2	4	9.4.4.2	5	9.1.3.8	12			9.2.3.4	9
	33		34		8		35		31		25		35		34		8		24		29		8		35

Pilot:

A/C:

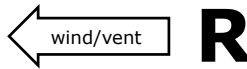

Figure K
339
 Total K
369

Judges Name	
Signature	Number

Flight #
N

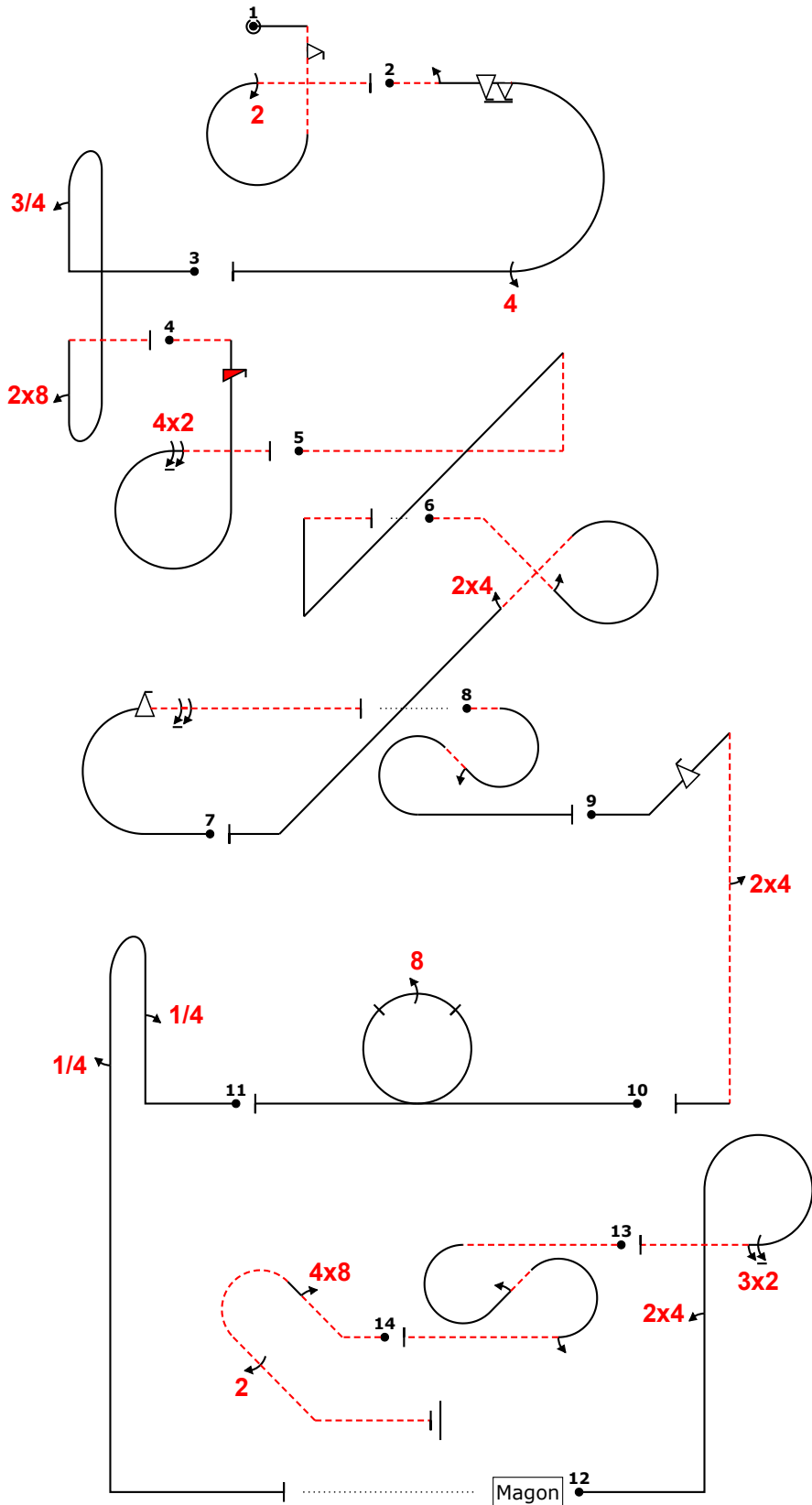

Fig	Grade	Pos	Remarks
1	.		
2	.		
3	.		
4	.		
5	.		
6	.		
7	.		
8	.		
9	.		
10	.		
11	.		
12	.		
13	.		
14	.		

Positioning
30

Too Low		Trg Violation	
Too High		Wing Rocks	
Interruptions		Disqual Fig	
Insertions		Other(note...)	

Fig 1 D	K	Fig 2 B	K	Fig 3 H	K	Fig 4 F	K	Fig 5 L	K	Fig 6 I	K	Fig 7 C	K	Fig 8 L	K	Fig 9 E	K	Fig 10 J	K	Fig 11 L	K	Fig 12 G	K	Fig 13 L	K	Fig 14 A	K
8.6.3.3	13	7.2.1.4	6	8.8.1.1	18	8.6.1.4	12	1.3.9.2	24	7.3.4.4	15	7.2.1.1	6	7.5.2.4	15	1.2.1.1	13	7.4.1.1	10	8.4.1.1	13	8.6.2.1	12	7.5.7.4	15	8.4.15.2	16
9.9.10.2	13	9.1.3.2	4	9.1.1.3	10	9.12.1.4	7			9.1.4.2	4	9.9.3.4	11	9.1.2.2	6	9.9.2.4	13	9.8.3.4	15	9.1.1.1	6	9.4.1.2	9	9.1.2.2	6	9.8.2.2	9
9.2.3.4	9	9.9.3.6	14	9.8.1.1	7	9.2.3.8	15			9.4.4.2	5	9.1.3.8	12			9.4.5.2	5			9.1.5.1	2	9.2.3.6	12	9.1.3.2	4	9.2.4.4	9
		9.4.3.4	11																								
	35		35		35		34		6		24		29		6		31		25		6		33		6		34



Figure K
339
 Total K
369

Judges Name	
Signature	Number

Flight #
N

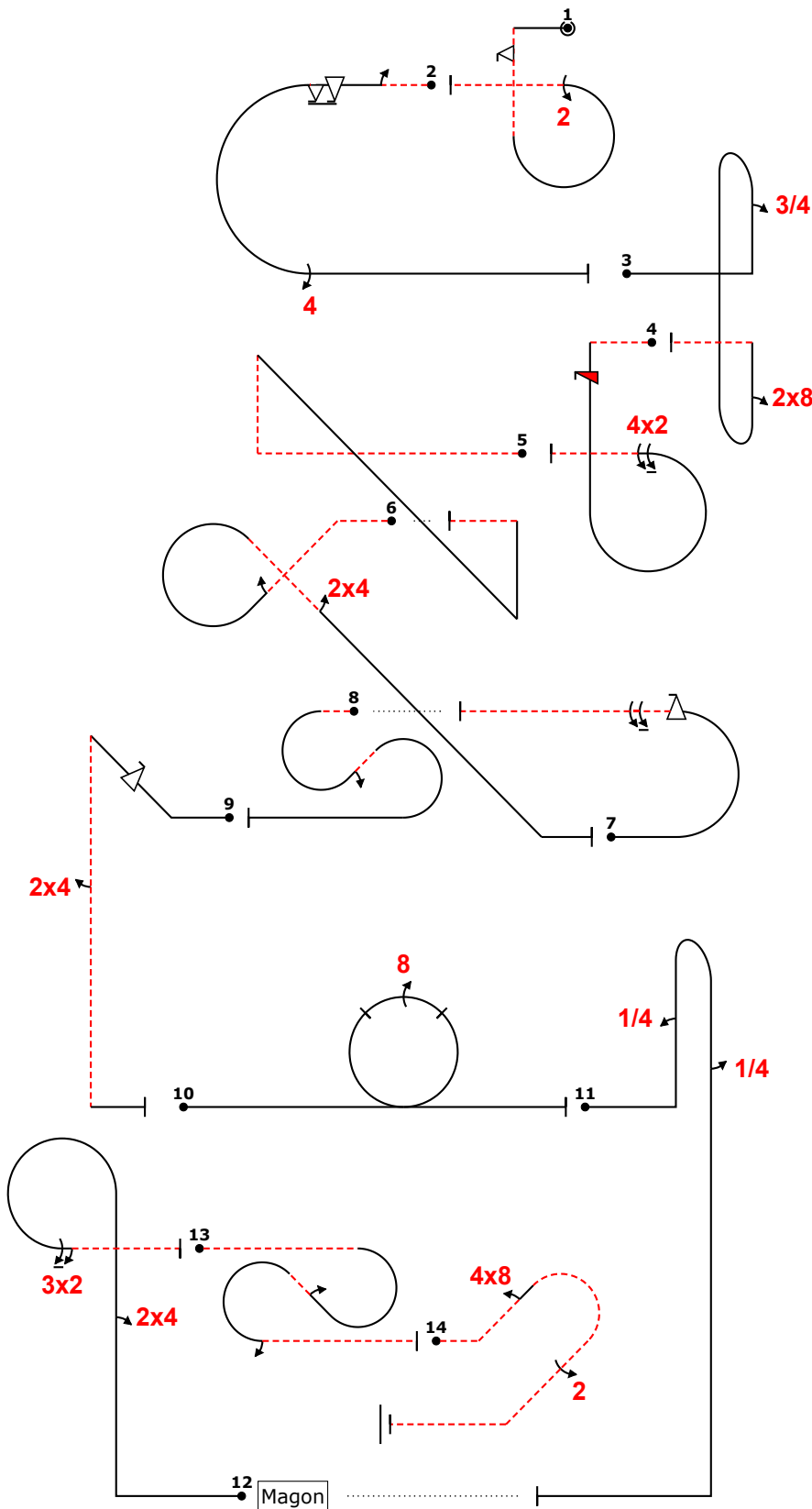
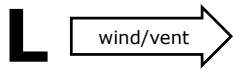

Fig	Grade	Pos	Remarks
1	.		
2	.		
3	.		
4	.		
5	.		
6	.		
7	.		
8	.		
9	.		
10	.		
11	.		
12	.		
13	.		
14	.		

Positioning
30

Too Low		Trg Violation	
Too High		Wing Rocks	
Interruptions		Disqual Fig	
Insertions		Other(note...)	

Fig 1 D	K	Fig 2 B	K	Fig 3 H	K	Fig 4 F	K	Fig 5 L	K	Fig 6 I	K	Fig 7 C	K	Fig 8 L	K	Fig 9 E	K	Fig 10 J	K	Fig 11 L	K	Fig 12 G	K	Fig 13 L	K	Fig 14 A	K
8.6.3.3	13	7.2.1.4	6	8.8.1.1	18	8.6.1.4	12	1.3.9.2	24	7.3.4.4	15	7.2.1.1	6	7.5.2.4	15	1.2.1.1	13	7.4.1.1	10	8.4.1.1	13	8.6.2.1	12	7.5.7.4	15	8.4.15.2	16
9.9.10.2	13	9.1.3.2	4	9.1.1.3	10	9.12.1.4	7			9.1.4.2	4	9.9.3.4	11	9.1.2.2	6	9.9.2.4	13	9.8.3.4	15	9.1.1.1	6	9.4.1.2	9	9.1.2.2	6	9.8.2.2	9
9.2.3.4	9	9.9.3.6	14	9.8.1.1	7	9.2.3.8	15			9.4.4.2	5	9.1.3.8	12			9.4.5.2	5			9.1.5.1	2	9.2.3.6	12	9.1.3.2	4	9.2.4.4	9
		9.4.3.4	11																								
	35		35		35		34		6		24		29		6		31		25		6		33		6		34

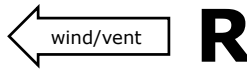

Figure K
339
 Total K
369

Judges Name	
Signature	Number

Flight #
0

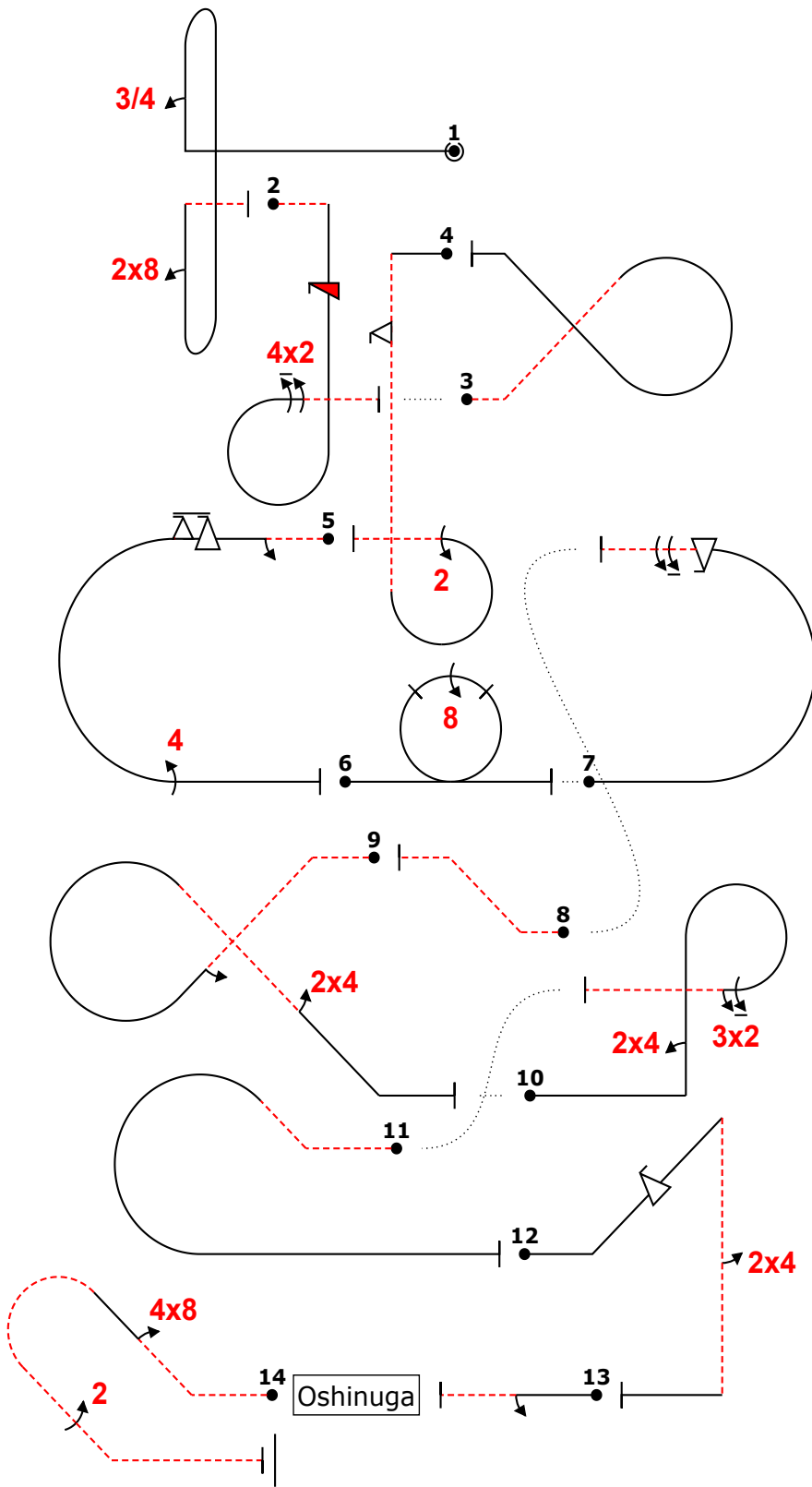

Fig	Grade	Pos	Remarks
1	.		
2	.		
3	.		
4	.		
5	.		
6	.		
7	.		
8	.		
9	.		
10	.		
11	.		
12	.		
13	.		
14	.		

Positioning
30

Too Low		Trg Violation	
Too High		Wing Rocks	
Interruptions		Disqual Fig	
Insertions		Other(note...)	

Fig 1 H	K	Fig 2 A	K	Fig 3 L	K	Fig 4 I	K	Fig 5 B	K	Fig 6 C	K	Fig 7 D	K	Fig 8 L	K	Fig 9 E	K	Fig 10 F	K	Fig 11 L	K	Fig 12 G	K	Fig 13 L	K	Fig 14 J	K
8.8.1.1	18	8.6.1.4	12	7.3.1.2	14	8.6.3.3	13	7.2.1.4	6	7.4.1.1	10	7.2.1.1	6	1.1.2.2	8	7.3.4.4	15	8.6.2.1	12	8.5.1.2	10	1.2.1.1	13	1.1.1.3	2	8.4.15.2	16
9.1.1.3	10	9.12.1.4	7			9.9.10.2	13	9.1.3.2	4	9.8.3.4	15	9.9.3.4	11			9.1.4.2	4	9.4.1.2	9			9.9.2.4	13	9.1.3.2	4	9.8.2.2	9
9.8.1.1	7	9.2.3.8	15			9.2.3.4	9	9.9.3.6	14			9.1.3.8	12			9.4.4.2	5	9.2.3.6	12			9.4.5.2	5			9.2.4.4	9
	35		34		6		35		35		25		29		6		24		33		6		31		6		34

Pilot: **Anthony Oshinuga**

A/C: **Pitts S1S**



Figure K
 339
 Total K
 369

Judges Name	
Signature	Number

Flight #
 0

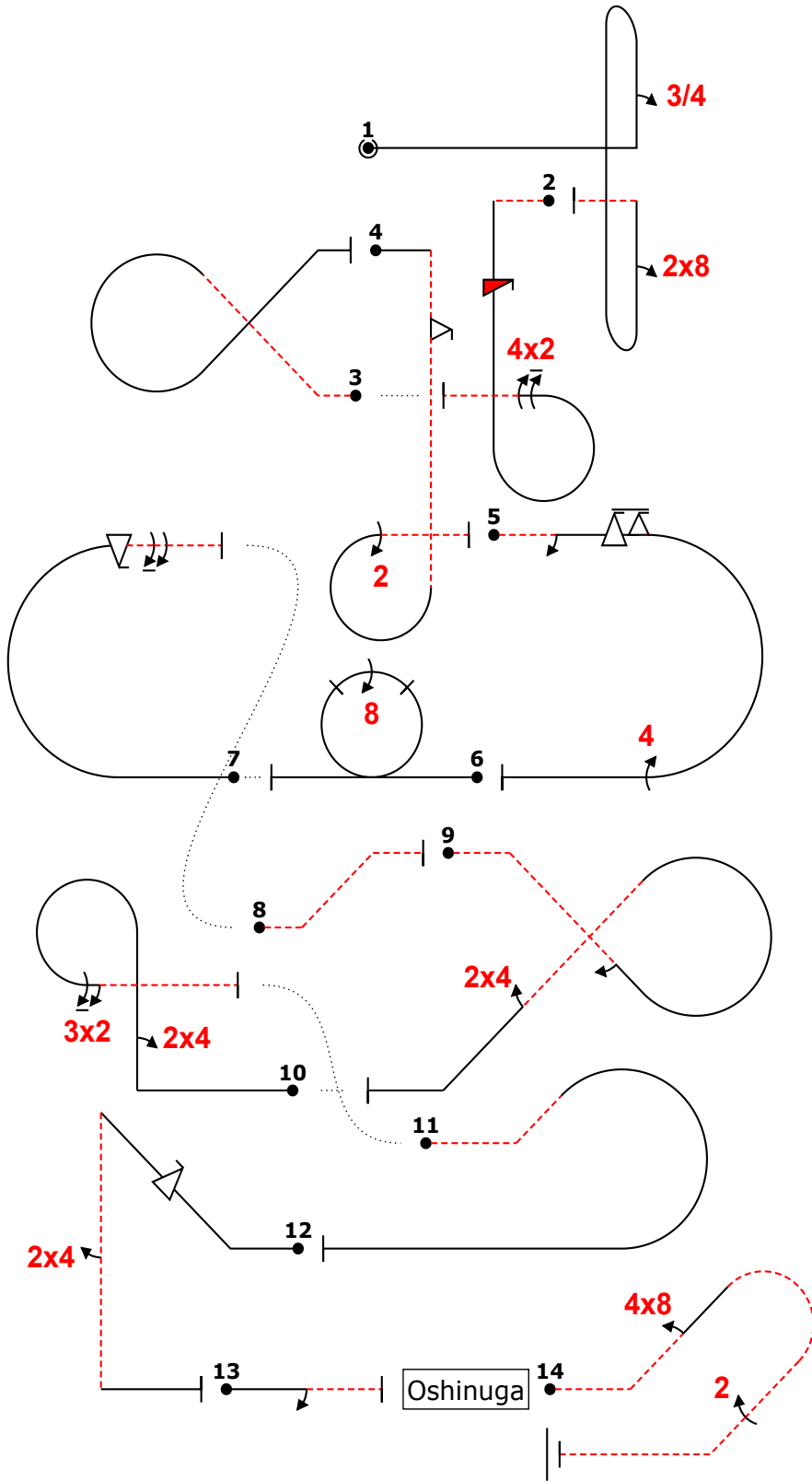
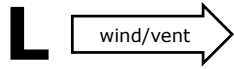

Fig	Grade	Pos	Remarks
1	.		
2	.		
3	.		
4	.		
5	.		
6	.		
7	.		
8	.		
9	.		
10	.		
11	.		
12	.		
13	.		
14	.		

Positioning
 30

Too Low		Trg Violation	
Too High		Wing Rocks	
Interruptions		Disqual Fig	
Insertions		Other(note...)	

Fig 1 H	K	Fig 2 A	K	Fig 3 L	K	Fig 4 I	K	Fig 5 B	K	Fig 6 C	K	Fig 7 D	K	Fig 8 L	K	Fig 9 E	K	Fig 10 F	K	Fig 11 L	K	Fig 12 G	K	Fig 13 L	K	Fig 14 J	K
8.8.1.1	18	8.6.1.4	12	7.3.1.2	14	8.6.3.3	13	7.2.1.4	6	7.4.1.1	10	7.2.1.1	6	1.1.2.2	8	7.3.4.4	15	8.6.2.1	12	8.5.1.2	10	1.2.1.1	13	1.1.1.3	2	8.4.15.2	16
9.1.1.3	10	9.12.1.4	7			9.9.10.2	13	9.1.3.2	4	9.8.3.4	15	9.9.3.4	11			9.1.4.2	4	9.4.1.2	9			9.9.2.4	13	9.1.3.2	4	9.8.2.2	9
9.8.1.1	7	9.2.3.8	15			9.2.3.4	9	9.9.3.6	14			9.1.3.8	12			9.4.4.2	5	9.2.3.6	12			9.4.5.2	5			9.2.4.4	9
	35		34		6		35		35		25		29		6		24		33		6		31		6		34

Pilot: Anthony Oshinuga

A/C: Pitts S1S



CIVA Advanced

Programme3

Figure K

339

Total K

369

Judges Name	
Signature	Number

Flight #
P

wind/vent **R**

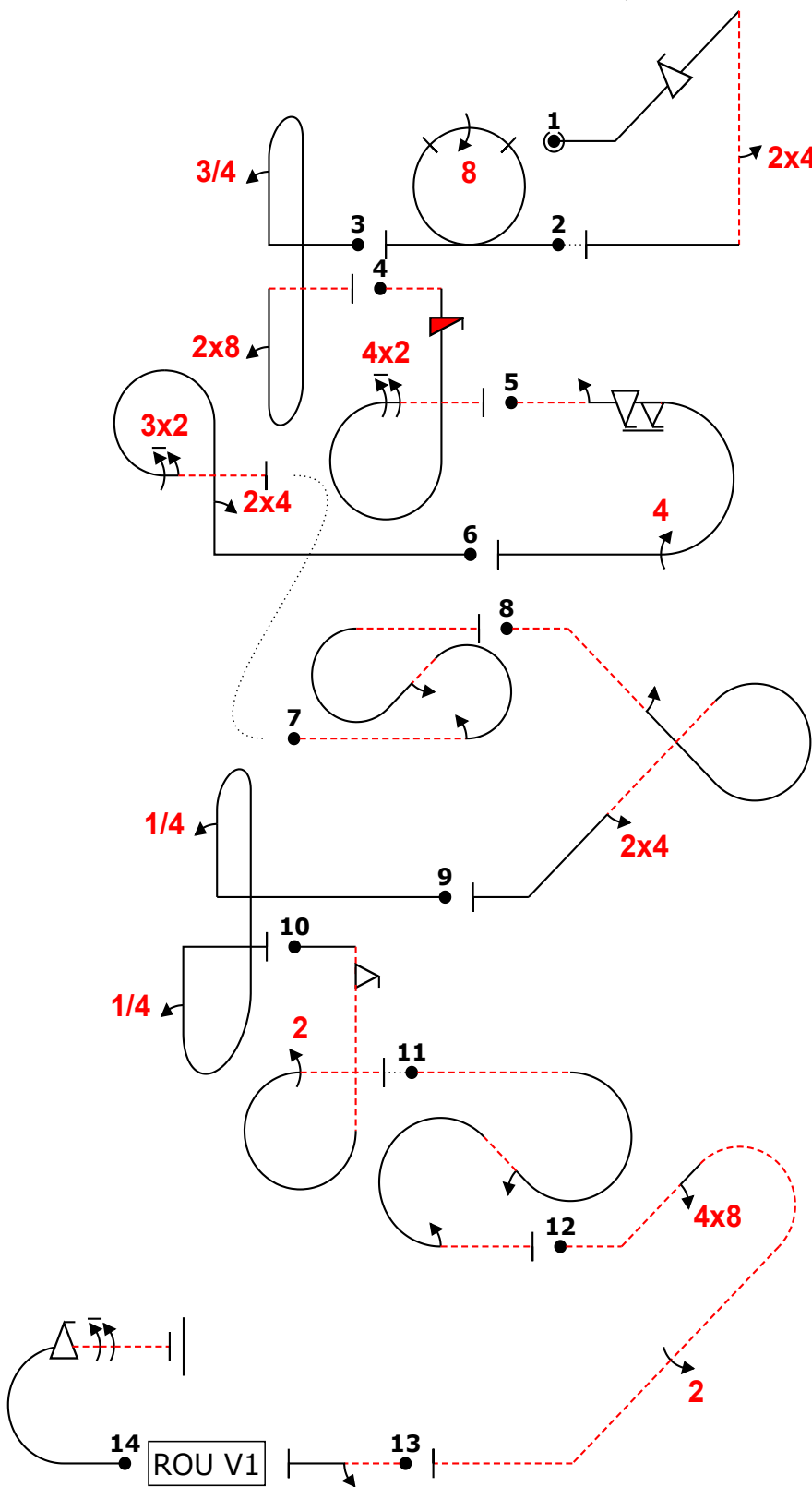

Fig	Grade	Pos	Remarks
1	.		
2	.		
3	.		
4	.		
5	.		
6	.		
7	.		
8	.		
9	.		
10	.		
11	.		
12	.		
13	.		
14	.		

Positioning	30	.
-------------	----	---

Too Low		Trg Violation	
Too High		Wing Rocks	
Interruptions		Disqual Fig	
Insertions		Other(note...)	

Fig 1 E	K	Fig 2 J	K	Fig 3 H	K	Fig 4 F	K	Fig 5 B	K	Fig 6 G	K	Fig 7 L	K	Fig 8 I	K	Fig 9 L	K	Fig 10 D	K	Fig 11 L	K	Fig 12 A	K	Fig 13 L	K	Fig 14 C	K
1.2.1.1	13	7.4.1.1	10	8.8.1.1	18	8.6.1.4	12	7.2.1.4	6	8.6.2.1	12	7.5.5.2	15	7.3.4.4	15	8.8.2.1	19	8.6.3.3	13	7.5.7.4	15	8.4.15.2	16	1.1.1.4	2	7.2.1.1	6
9.9.2.4	13	9.8.3.4	15	9.1.1.3	10	9.12.1.4	7	9.1.3.2	4	9.4.1.2	9	9.1.3.2	4	9.1.4.2	4	9.1.1.1	6	9.9.10.2	13	9.1.2.2	6	9.8.2.2	9	9.1.3.2	4	9.9.3.4	11
9.4.5.2	5			9.8.1.1	7	9.2.3.8	15	9.9.3.6	14	9.2.3.6	12	9.1.4.2	4	9.4.4.2	5	9.1.1.1	6	9.2.3.4	9	9.1.3.2	4	9.2.4.4	9			9.1.3.8	12
	31		25		35		34		35		33		6		24		6		35		6		34		6		29

Pilot:

A/C:

Team: ROU



Judges Name	
Signature	Number

Flight #
P

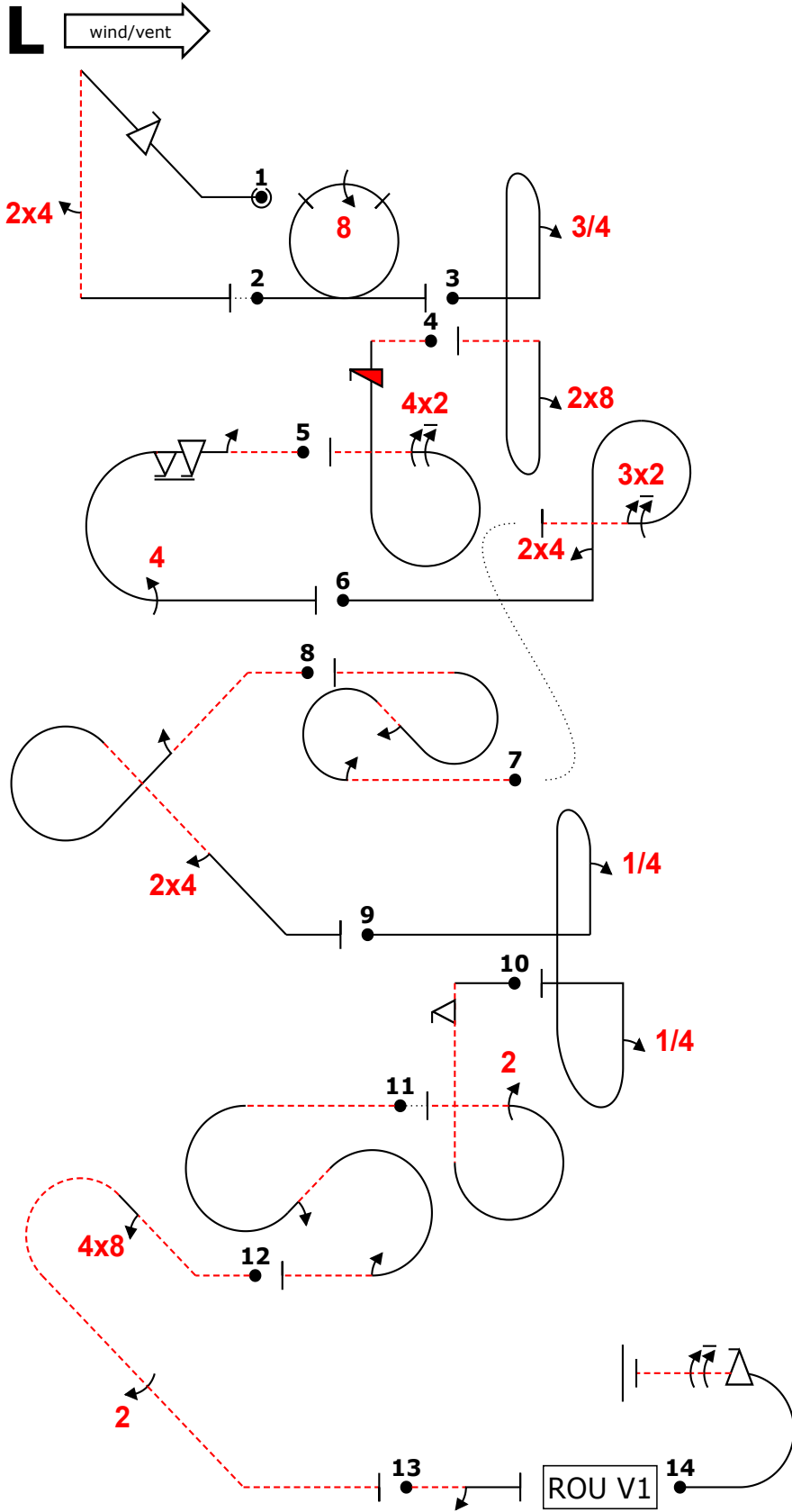

Fig	Grade	Pos	Remarks
1	.		
2	.		
3	.		
4	.		
5	.		
6	.		
7	.		
8	.		
9	.		
10	.		
11	.		
12	.		
13	.		
14	.		

Positioning	30	.
-------------	----	---

Too Low		Trg Violation	
Too High		Wing Rocks	
Interruptions		Disqual Fig	
Insertions		Other(note...)	

Fig 1 E	K	Fig 2 J	K	Fig 3 H	K	Fig 4 F	K	Fig 5 B	K	Fig 6 G	K	Fig 7 L	K	Fig 8 I	K	Fig 9 L	K	Fig 10 D	K	Fig 11 L	K	Fig 12 A	K	Fig 13 L	K	Fig 14 C	K
1.2.1.1	13	7.4.1.1	10	8.8.1.1	18	8.6.1.4	12	7.2.1.4	6	8.6.2.1	12	7.5.5.2	15	7.3.4.4	15	8.8.2.1	19	8.6.3.3	13	7.5.7.4	15	8.4.15.2	16	1.1.1.4	2	7.2.1.1	6
9.9.2.4	13	9.8.3.4	15	9.1.1.3	10	9.12.1.4	7	9.1.3.2	4	9.4.1.2	9	9.1.3.2	4	9.1.4.2	4	9.1.1.1	6	9.9.10.2	13	9.1.2.2	6	9.8.2.2	9	9.1.3.2	4	9.9.3.4	11
9.4.5.2	5			9.8.1.1	7	9.2.3.8	15	9.9.3.6	14	9.2.3.6	12	9.1.4.2	4	9.4.4.2	5	9.1.1.1	6	9.2.3.4	9	9.1.3.2	4	9.2.4.4	9			9.1.3.8	12
	31		25		35		34		35		33		6		24		6		35		6		34		6		29

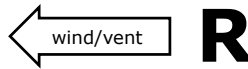

Figure K
 339
 Total K
 369

Judges Name	
Signature	Number

Flight #
 Q

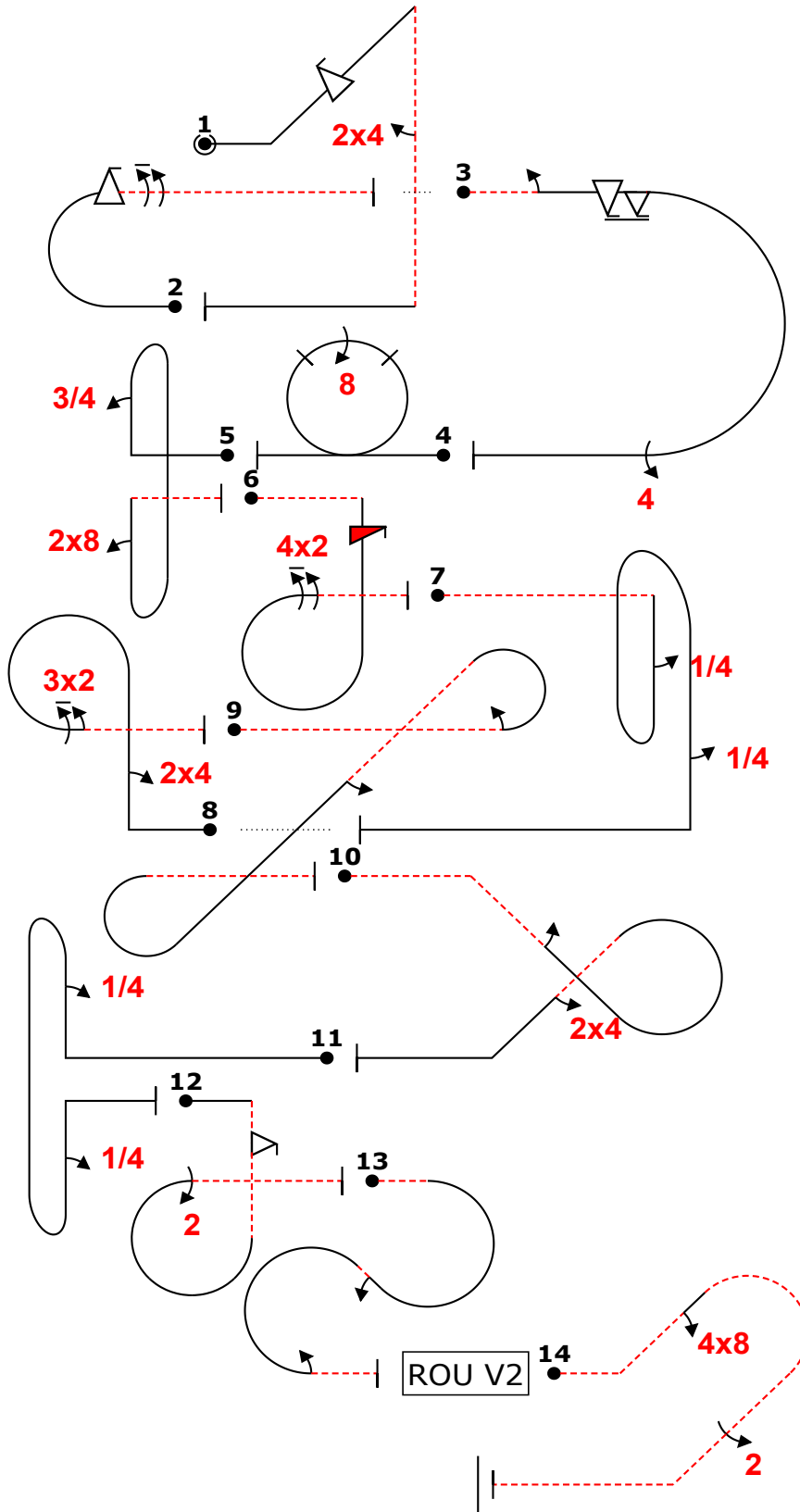

Fig	Grade	Pos	Remarks
1	.		
2	.		
3	.		
4	.		
5	.		
6	.		
7	.		
8	.		
9	.		
10	.		
11	.		
12	.		
13	.		
14	.		

Positioning
 30 .

Too Low		Trg Violation	
Too High		Wing Rocks	
Interruptions		Disqual Fig	
Insertions		Other(note...)	

Fig 1 E	K	Fig 2 C	K	Fig 3 B	K	Fig 4 J	K	Fig 5 H	K	Fig 6 F	K	Fig 7 L	K	Fig 8 G	K	Fig 9 L	K	Fig 10 I	K	Fig 11 L	K	Fig 12 D	K	Fig 13 L	K	Fig 14 A	K		
1.2.1.1	13	7.2.1.1	6	7.2.1.4	6	7.4.1.1	10	8.8.1.1	18	8.6.1.4	12	8.8.1.4	18	8.6.2.1	12	7.5.5.2	15	7.3.4.4	15	8.8.2.1	19	8.6.3.3	13	7.5.7.4	15	8.4.15.2	16		
9.9.2.4	13	9.9.3.4	11	9.1.3.2	4	9.8.3.4	15	9.1.1.3	10	9.12.1.4	7	9.1.5.1	2	9.4.1.2	9	9.1.3.2	4	9.1.4.2	4	9.1.1.1	6	9.9.10.2	13	9.1.2.2	6	9.8.2.2	9		
9.4.5.2	5	9.1.3.8	12	9.9.3.6	14			9.8.1.1	7	9.2.3.8	15	9.1.5.1	2	9.2.3.6	12	9.1.4.2	4	9.4.4.2	5	9.1.1.1	6	9.2.3.4	9	9.1.3.2	4	9.2.4.4	9		
	31		29	9.4.3.4	11		35		25		35		34		6		33		6		24		6		35		6		34

Pilot:

A/C:

Team: ROU



Figure K
 339
 Total K
 369

Judges Name	
Signature	Number

Flight #
 Q

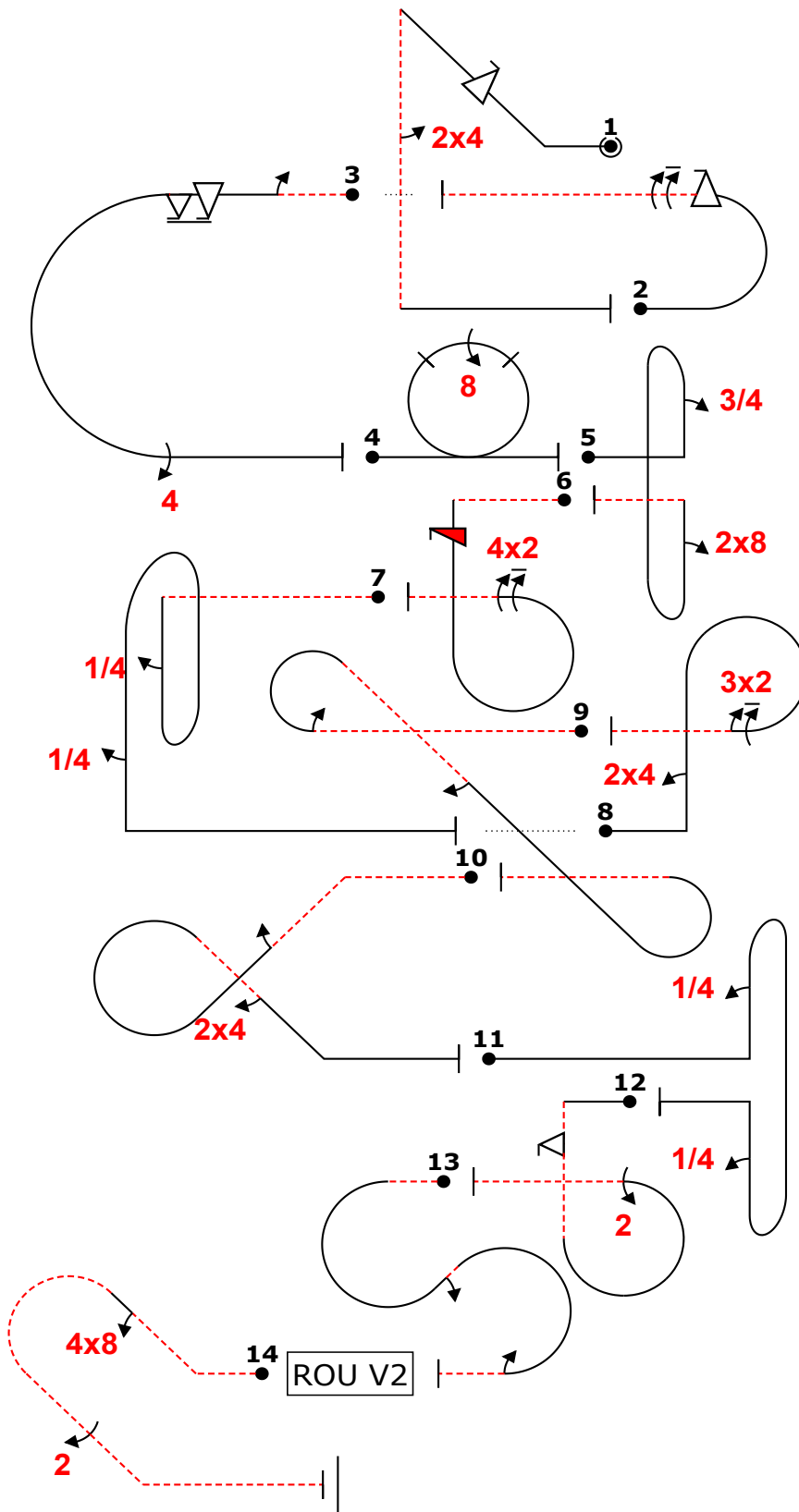
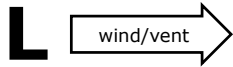

Fig	Grade	Pos	Remarks
1	.		
2	.		
3	.		
4	.		
5	.		
6	.		
7	.		
8	.		
9	.		
10	.		
11	.		
12	.		
13	.		
14	.		

Positioning
 30

Too Low		Trg Violation	
Too High		Wing Rocks	
Interruptions		Disqual Fig	
Insertions		Other(note...)	

Fig 1 E	K	Fig 2 C	K	Fig 3 B	K	Fig 4 J	K	Fig 5 H	K	Fig 6 F	K	Fig 7 L	K	Fig 8 G	K	Fig 9 L	K	Fig 10 I	K	Fig 11 L	K	Fig 12 D	K	Fig 13 L	K	Fig 14 A	K		
1.2.1.1	13	7.2.1.1	6	7.2.1.4	6	7.4.1.1	10	8.8.1.1	18	8.6.1.4	12	8.8.1.4	18	8.6.2.1	12	7.5.5.2	15	7.3.4.4	15	8.8.2.1	19	8.6.3.3	13	7.5.7.4	15	8.4.15.2	16		
9.9.2.4	13	9.9.3.4	11	9.1.3.2	4	9.8.3.4	15	9.1.1.3	10	9.12.1.4	7	9.1.5.1	2	9.4.1.2	9	9.1.3.2	4	9.1.4.2	4	9.1.1.1	6	9.9.10.2	13	9.1.2.2	6	9.8.2.2	9		
9.4.5.2	5	9.1.3.8	12	9.9.3.6	14			9.8.1.1	7	9.2.3.8	15	9.1.5.1	2	9.2.3.6	12	9.1.4.2	4	9.4.4.2	5	9.1.1.1	6	9.2.3.4	9	9.1.3.2	4	9.2.4.4	9		
	31		29	9.4.3.4	11		35		25		35		34		6		33		6		24		6		35		6		34

Pilot:

A/C:

Team: ROU



CIVA Advanced

Unknown2

Figure K

339

Total K

369

Judges Name

Signature

Number

Flight #

R

wind/vent

R

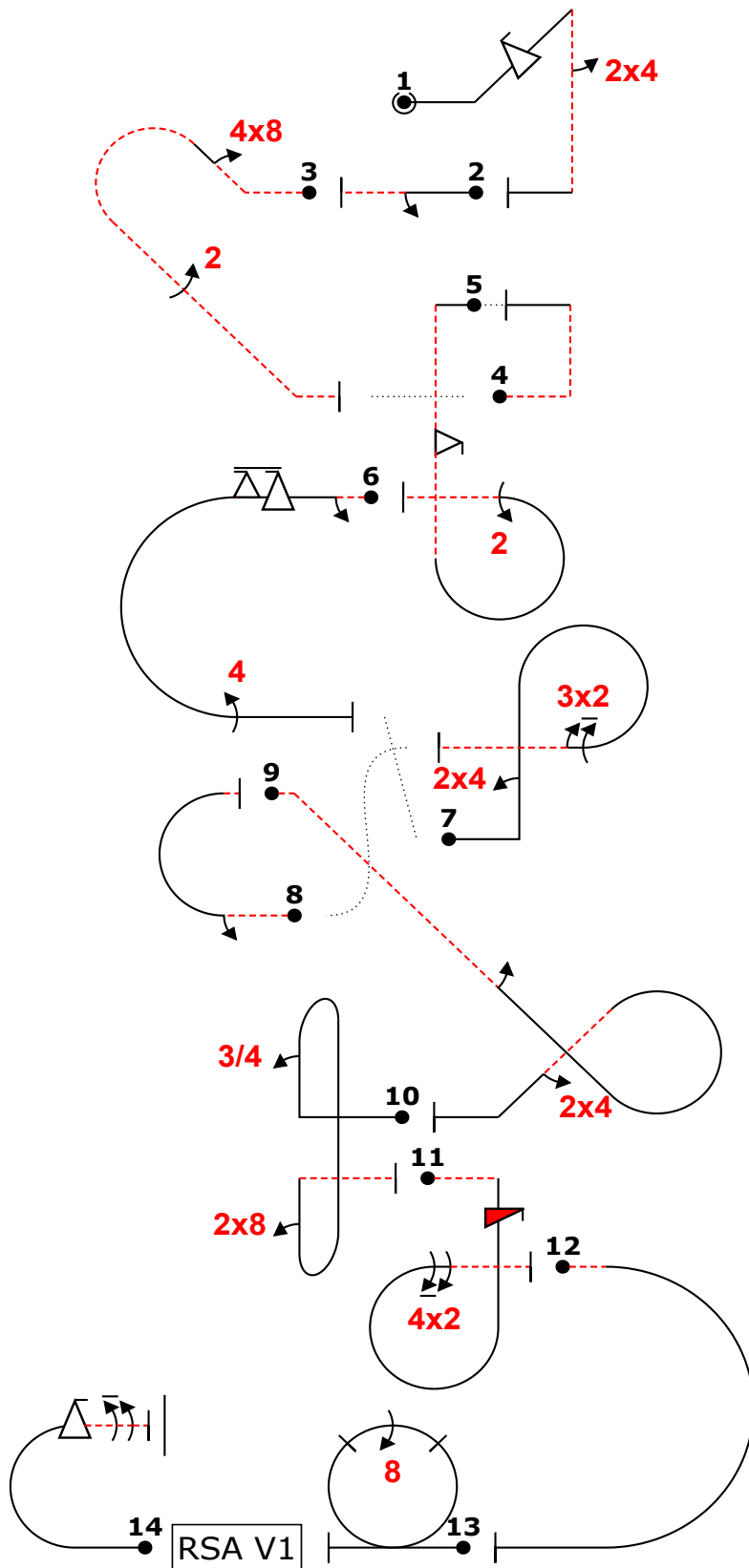

Fig	Grade	Pos	Remarks
1	.		
2	.		
3	.		
4	.		
5	.		
6	.		
7	.		
8	.		
9	.		
10	.		
11	.		
12	.		
13	.		
14	.		

Positioning

30

.

Too Low

Trg Violation

Too High

Wing Rocks

Interruptions

Disqual Fig

Insertions

Other(note...)

Fig 1 E	K	Fig 2 L	K	Fig 3 A	K	Fig 4 L	K	Fig 5 D	K	Fig 6 B	K	Fig 7 G	K	Fig 8 L	K	Fig 9 I	K	Fig 10 H	K	Fig 11 F	K	Fig 12 L	K	Fig 13 J	K	Fig 14 C	K
1.2.1.1	13	1.1.1.3	2	8.4.15.2	16	1.1.7.2	12	8.6.3.3	13	7.2.1.4	6	8.6.2.1	12	7.2.3.2	7	7.3.4.4	15	8.8.1.1	18	8.6.1.4	12	7.2.1.4	6	7.4.1.1	10	7.2.1.1	6
9.9.2.4	13	9.1.3.2	4	9.8.2.2	9			9.9.10.2	13	9.1.3.2	4	9.4.1.2	9	9.1.3.2	4	9.1.4.2	4	9.1.1.3	10	9.12.1.4	7			9.8.3.4	15	9.9.3.4	11
9.4.5.2	5			9.2.4.4	9			9.2.3.4	9	9.9.3.6	14	9.2.3.6	12			9.4.4.2	5	9.8.1.1	7	9.2.3.8	15					9.1.3.8	12
	31		6		34		6		35		35		33		6		24		35		34		6		25		29

Pilot:

A/C:

Team: RSA



CIVA Advanced

Unknown2

Figure K

339

Total K

369

Judges Name	
Signature	Number

Flight #
R

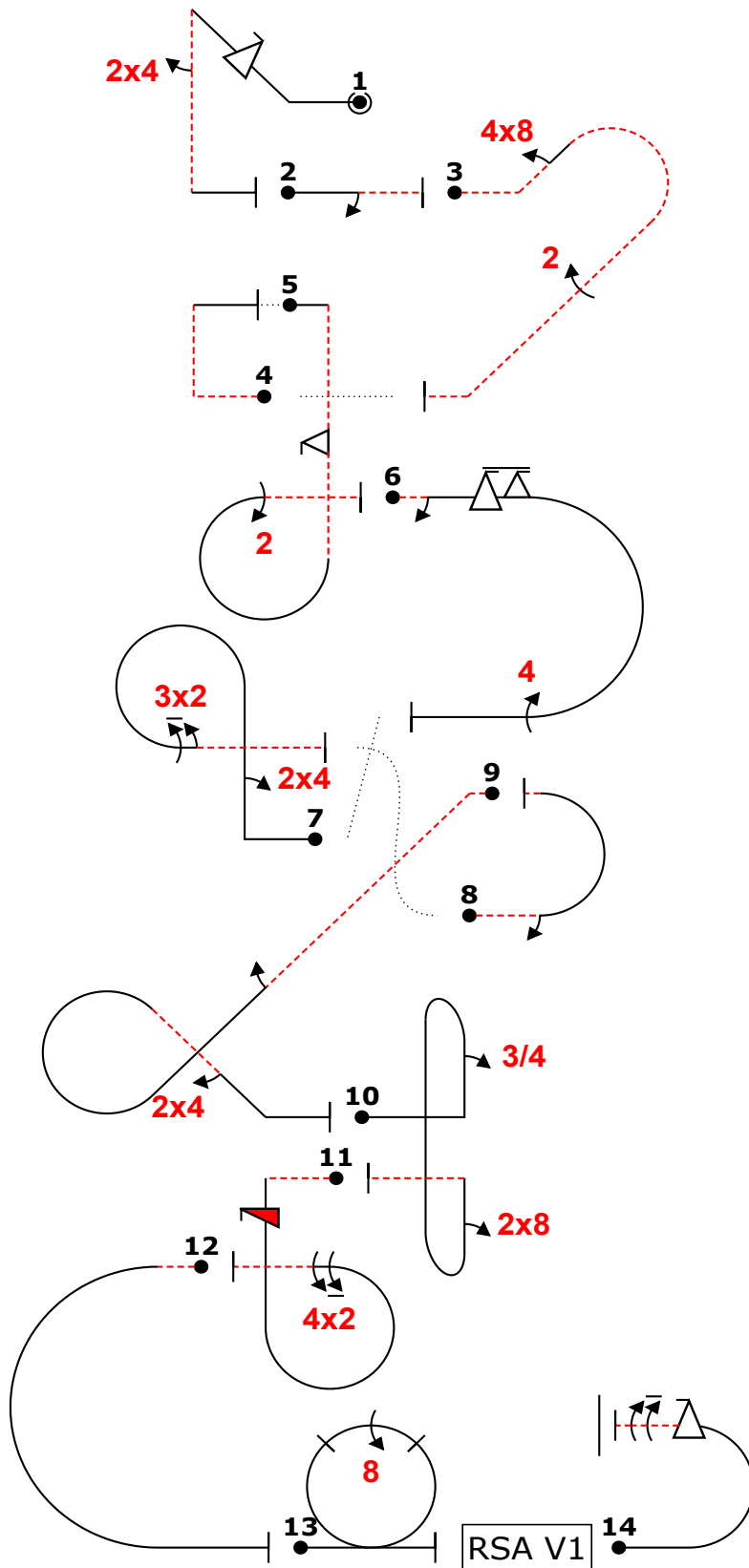
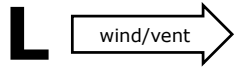

Fig	Grade	Pos	Remarks
1	.		
2	.		
3	.		
4	.		
5	.		
6	.		
7	.		
8	.		
9	.		
10	.		
11	.		
12	.		
13	.		
14	.		

Positioning	30	.
-------------	----	---

Too Low		Trg Violation	
Too High		Wing Rocks	
Interruptions		Disqual Fig	
Insertions		Other(note...)	

Fig 1 E	K	Fig 2 L	K	Fig 3 A	K	Fig 4 L	K	Fig 5 D	K	Fig 6 B	K	Fig 7 G	K	Fig 8 L	K	Fig 9 I	K	Fig 10 H	K	Fig 11 F	K	Fig 12 L	K	Fig 13 J	K	Fig 14 C	K
1.2.1.1	13	1.1.1.3	2	8.4.15.2	16	1.1.7.2	12	8.6.3.3	13	7.2.1.4	6	8.6.2.1	12	7.2.3.2	7	7.3.4.4	15	8.8.1.1	18	8.6.1.4	12	7.2.1.4	6	7.4.1.1	10	7.2.1.1	6
9.9.2.4	13	9.1.3.2	4	9.8.2.2	9			9.9.10.2	13	9.1.3.2	4	9.4.1.2	9	9.1.3.2	4	9.1.4.2	4	9.1.1.3	10	9.12.1.4	7			9.8.3.4	15	9.9.3.4	11
9.4.5.2	5			9.2.4.4	9			9.2.3.4	9	9.9.3.6	14	9.2.3.6	12			9.4.4.2	5	9.8.1.1	7	9.2.3.8	15					9.1.3.8	12
	31		6		34		6		35		35		33		6		24		35		34		6		25		29

Pilot:

A/C:

Team: RSA

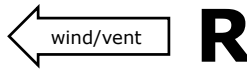

Figure K
339
 Total K
369

Judges Name	
Signature	Number

Flight #
S

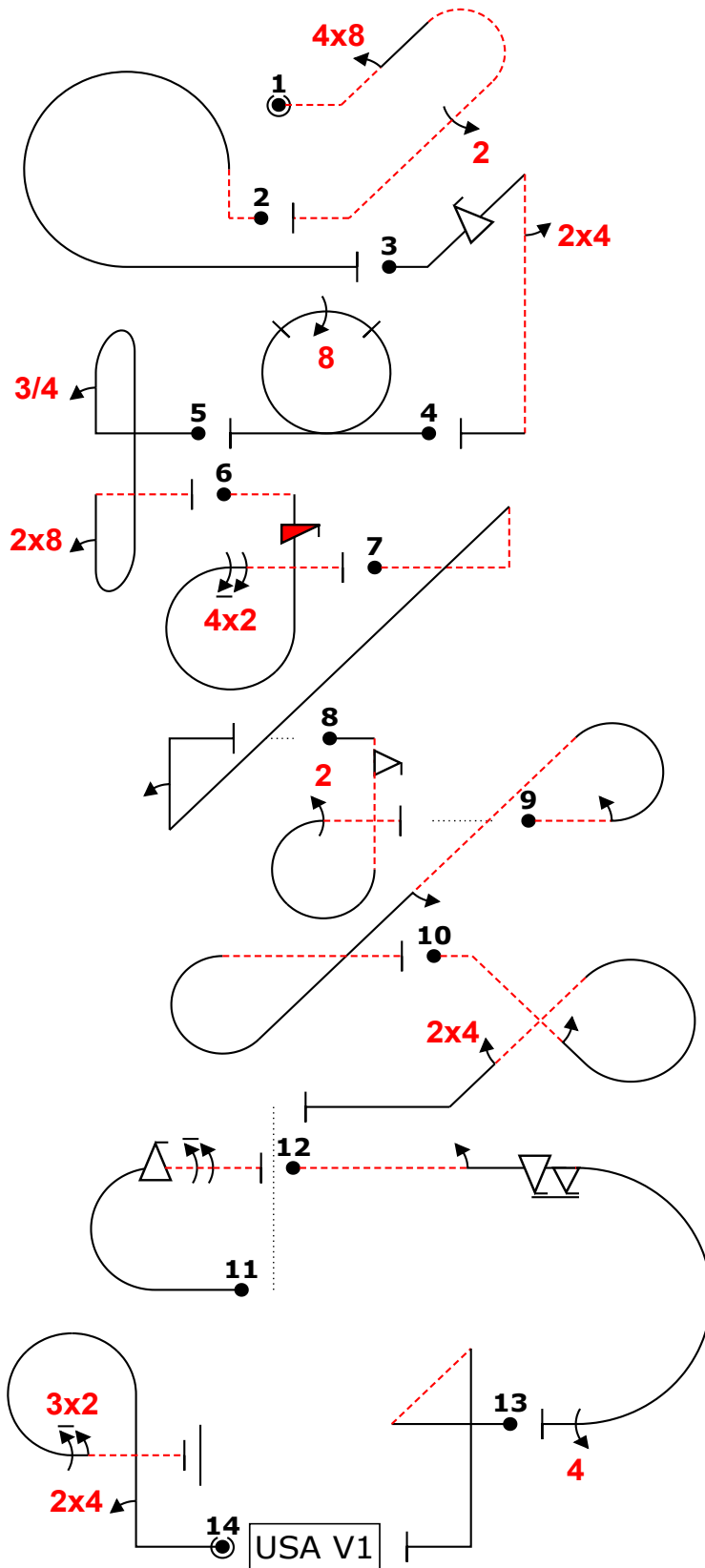

Fig	Grade	Pos	Remarks
1	.		
2	.		
3	.		
4	.		
5	.		
6	.		
7	.		
8	.		
9	.		
10	.		
11	.		
12	.		
13	.		
14	.		

Positioning
30

Too Low		Trg Violation	
Too High		Wing Rocks	
Interruptions		Disqual Fig	
Insertions		Other(note...)	

Fig 1 A	K	Fig 2 L	K	Fig 3 E	K	Fig 4 J	K	Fig 5 H	K	Fig 6 F	K	Fig 7 L	K	Fig 8 D	K	Fig 9 L	K	Fig 10 I	K	Fig 11 C	K	Fig 12 B	K	Fig 13 L	K	Fig 14 G	K
8.4.15.2	16	8.6.3.2	13	1.2.1.1	13	7.4.1.1	10	8.8.1.1	18	8.6.1.4	12	1.3.10.2	24	8.6.3.3	13	7.5.5.2	15	7.3.4.4	15	7.2.1.1	6	7.2.1.4	6	1.2.9.1	15	8.6.2.1	12
9.8.2.2	9			9.9.2.4	13	9.8.3.4	15	9.1.1.3	10	9.12.1.4	7	9.1.1.2	8	9.9.10.2	13	9.1.3.2	4	9.1.4.2	4	9.9.3.4	11	9.1.3.2	4			9.4.1.2	9
9.2.4.4	9			9.4.5.2	5			9.8.1.1	7	9.2.3.8	15			9.2.3.4	9	9.1.4.2	4	9.4.4.2	5	9.1.3.8	12	9.9.3.6	14			9.2.3.6	12
	34		6		31		25		35		34		6		35		6		24		29		35		6		33

Pilot:

A/C:



Figure K
 339
 Total K
 369

Judges Name	
Signature	Number

Flight #
S

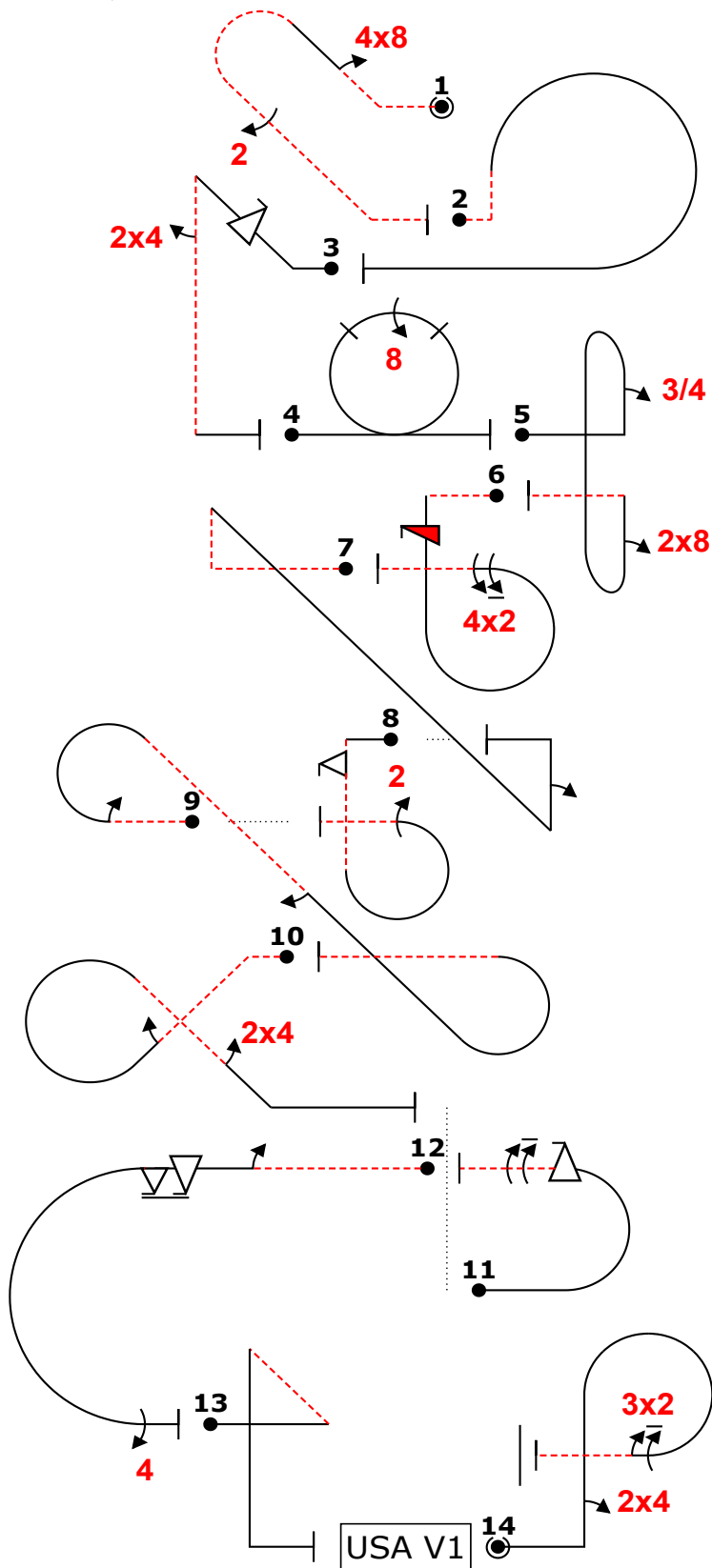
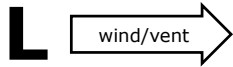

Fig	Grade	Pos	Remarks
1	.		
2	.		
3	.		
4	.		
5	.		
6	.		
7	.		
8	.		
9	.		
10	.		
11	.		
12	.		
13	.		
14	.		

Positioning
 30

Too Low		Trg Violation	
Too High		Wing Rocks	
Interruptions		Disqual Fig	
Insertions		Other(note...)	

Fig 1 A	K	Fig 2 L	K	Fig 3 E	K	Fig 4 J	K	Fig 5 H	K	Fig 6 F	K	Fig 7 L	K	Fig 8 D	K	Fig 9 L	K	Fig 10 I	K	Fig 11 C	K	Fig 12 B	K	Fig 13 L	K	Fig 14 G	K
8.4.15.2	16	8.6.3.2	13	1.2.1.1	13	7.4.1.1	10	8.8.1.1	18	8.6.1.4	12	1.3.10.2	24	8.6.3.3	13	7.5.5.2	15	7.3.4.4	15	7.2.1.1	6	7.2.1.4	6	1.2.9.1	15	8.6.2.1	12
9.8.2.2	9			9.9.2.4	13	9.8.3.4	15	9.1.1.3	10	9.12.1.4	7	9.1.1.2	8	9.9.10.2	13	9.1.3.2	4	9.1.4.2	4	9.9.3.4	11	9.1.3.2	4			9.4.1.2	9
9.2.4.4	9			9.4.5.2	5			9.8.1.1	7	9.2.3.8	15			9.2.3.4	9	9.1.4.2	4	9.4.4.2	5	9.1.3.8	12	9.9.3.6	14			9.2.3.6	12
	34		6		31		25		35		34		6		35		6		24		29		35		6		33

Pilot:

A/C:

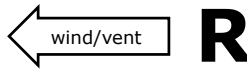

Figure K
 339
 Total K
 369

Judges Name	
Signature	Number

Flight #
T

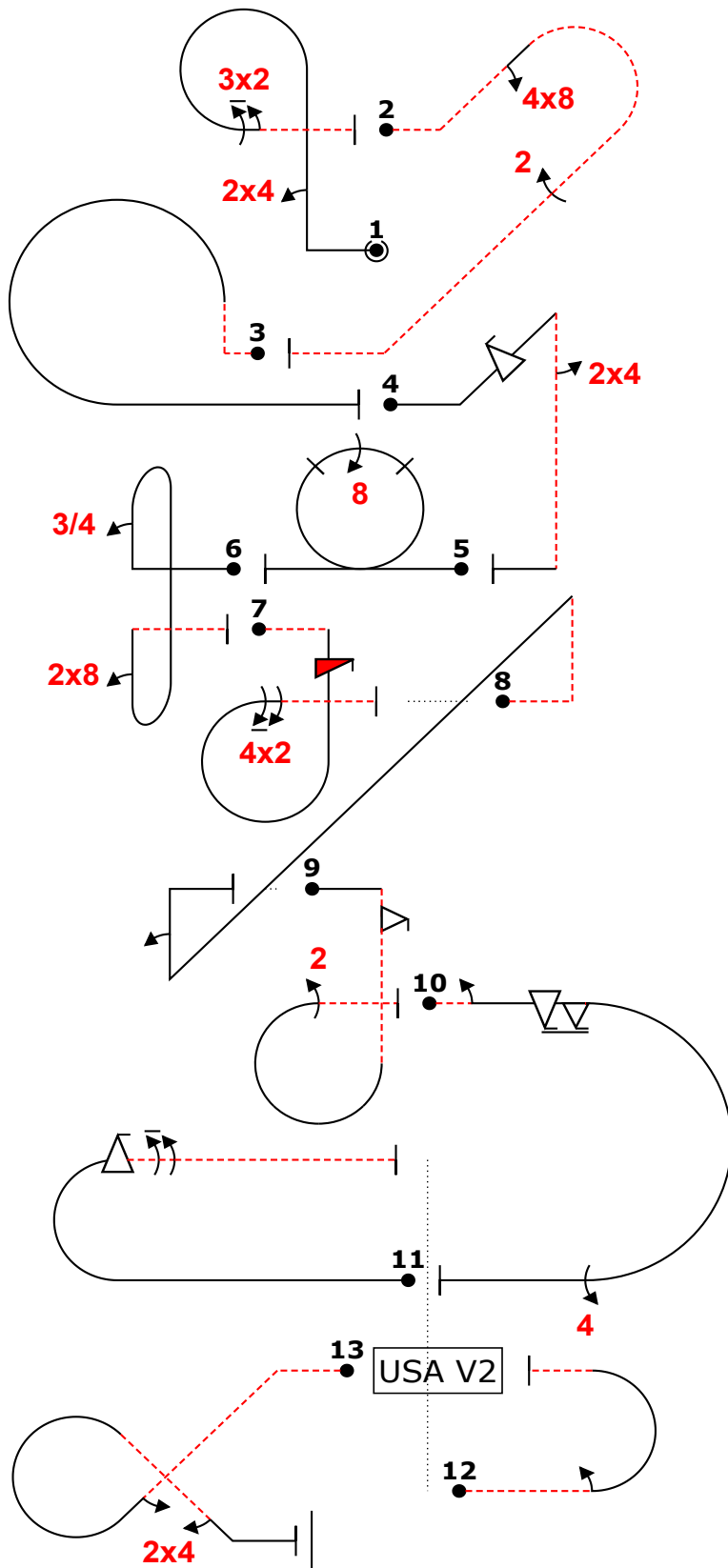

Fig	Grade	Pos	Remarks
1	.		
2	.		
3	.		
4	.		
5	.		
6	.		
7	.		
8	.		
9	.		
10	.		
11	.		
12	.		
13	.		

Positioning
 30 .

Too Low		Trg Violation	
Too High		Wing Rocks	
Interruptions		Disqual Fig	
Insertions		Other(note...)	

Fig 1 G	K	Fig 2 A	K	Fig 3 L	K	Fig 4 E	K	Fig 5 J	K	Fig 6 H	K	Fig 7 F	K	Fig 8 L	K	Fig 9 D	K	Fig 10 B	K	Fig 11 C	K	Fig 12 L	K	Fig 13 I	K
8.6.2.1	12	8.4.15.2	16	8.6.3.2	13	1.2.1.1	13	7.4.1.1	10	8.8.1.1	18	8.6.1.4	12	1.3.10.2	24	8.6.3.3	13	7.2.1.4	6	7.2.1.1	6	7.2.3.2	7	7.3.4.4	15
9.4.1.2	9	9.8.2.2	9			9.9.2.4	13	9.8.3.4	15	9.1.1.3	10	9.12.1.4	7	9.1.1.2	8	9.9.10.2	13	9.1.3.2	4	9.9.3.4	11	9.1.3.2	4	9.1.4.2	4
9.2.3.6	12	9.2.4.4	9			9.4.5.2	5			9.8.1.1	7	9.2.3.8	15			9.2.3.4	9	9.9.3.6	14	9.1.3.8	12			9.4.4.2	5
	33		34		8		31		25		35		34		8		35		35		29		8		24

Pilot:

A/C:

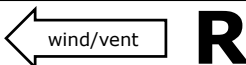

Figure K
339
 Total K
369

Judges Name	
Signature	Number

Flight #
U

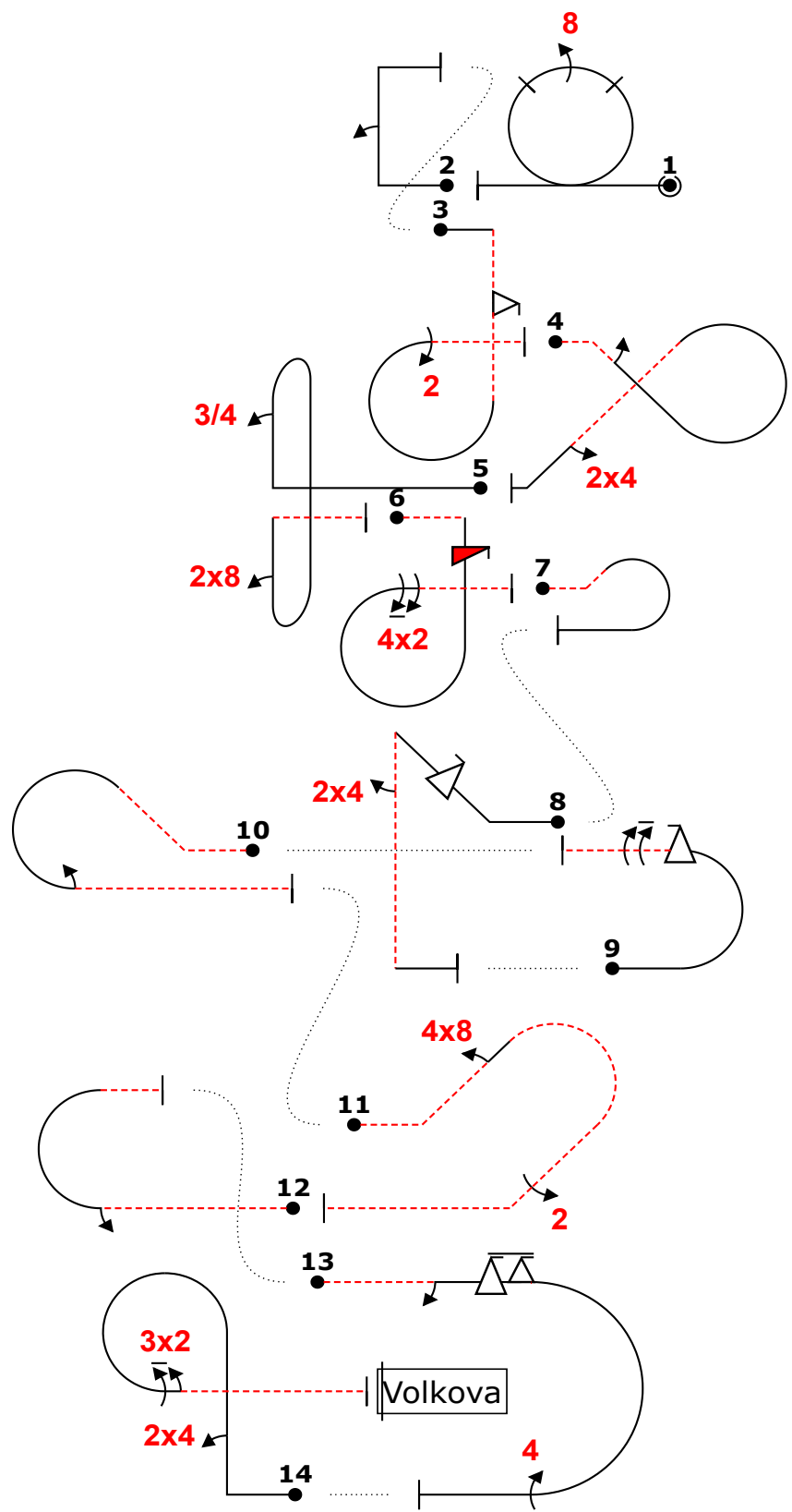

Fig	Grade	Pos	Remarks
1	.		
2	.		
3	.		
4	.		
5	.		
6	.		
7	.		
8	.		
9	.		
10	.		
11	.		
12	.		
13	.		
14	.		

Positioning
30

Too Low		Trg Violation	
Too High		Wing Rocks	
Interruptions		Disqual Fig	
Insertions		Other(note...)	

Fig 1 J	K	Fig 2 L	K	Fig 3 D	K	Fig 4 I	K	Fig 5 H	K	Fig 6 F	K	Fig 7 L	K	Fig 8 E	K	Fig 9 C	K	Fig 10 L	K	Fig 11 A	K	Fig 12 L	K	Fig 13 B	K	Fig 14 G	K
7.4.1.1	10	1.1.6.1	10	8.6.3.3	13	7.3.4.4	15	8.8.1.1	18	8.6.1.4	12	8.5.1.2	10	1.2.1.1	13	7.2.1.1	6	8.5.3.2	11	8.4.15.2	16	7.2.3.2	7	7.2.1.4	6	8.6.2.1	12
9.8.3.4	15	9.1.1.2	8	9.9.10.2	13	9.1.4.2	4	9.1.1.3	10	9.12.1.4	7			9.9.2.4	13	9.9.3.4	11	9.1.3.2	4	9.8.2.2	9	9.1.3.2	4	9.1.3.2	4	9.4.1.2	9
				9.2.3.4	9	9.4.4.2	5	9.8.1.1	7	9.2.3.8	15			9.4.5.2	5	9.1.3.8	12			9.2.4.4	9			9.9.3.6	14	9.2.3.6	12
	25		6		35		24		35		34		6		31		29		6		34		6		35		33



Figure K
339
 Total K
369

Judges Name	
Signature	Number

Flight #
U

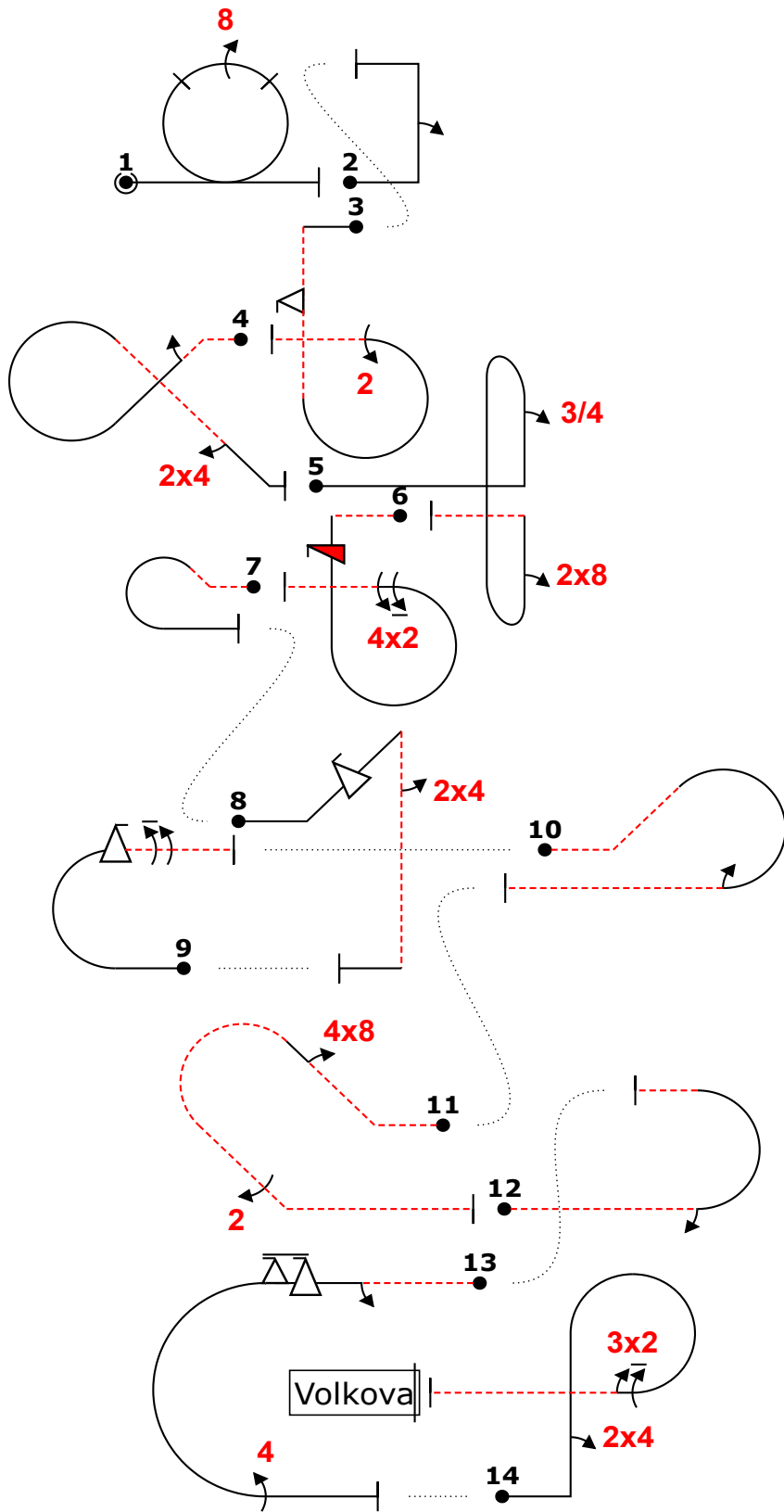
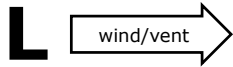

Fig	Grade	Pos	Remarks
1	.		
2	.		
3	.		
4	.		
5	.		
6	.		
7	.		
8	.		
9	.		
10	.		
11	.		
12	.		
13	.		
14	.		

Positioning
30

Too Low		Trg Violation	
Too High		Wing Rocks	
Interruptions		Disqual Fig	
Insertions		Other(note...)	

Fig 1 J	K	Fig 2 L	K	Fig 3 D	K	Fig 4 I	K	Fig 5 H	K	Fig 6 F	K	Fig 7 L	K	Fig 8 E	K	Fig 9 C	K	Fig 10 L	K	Fig 11 A	K	Fig 12 L	K	Fig 13 B	K	Fig 14 G	K
7.4.1.1	10	1.1.6.1	10	8.6.3.3	13	7.3.4.4	15	8.8.1.1	18	8.6.1.4	12	8.5.1.2	10	1.2.1.1	13	7.2.1.1	6	8.5.3.2	11	8.4.15.2	16	7.2.3.2	7	7.2.1.4	6	8.6.2.1	12
9.8.3.4	15	9.1.1.2	8	9.9.10.2	13	9.1.4.2	4	9.1.1.3	10	9.12.1.4	7			9.9.2.4	13	9.9.3.4	11	9.1.3.2	4	9.8.2.2	9	9.1.3.2	4	9.1.3.2	4	9.4.1.2	9
				9.2.3.4	9	9.4.4.2	5	9.8.1.1	7	9.2.3.8	15			9.4.5.2	5	9.1.3.8	12			9.2.4.4	9			9.9.3.6	14	9.2.3.6	12
	25		6		35		24		35		34		6		31		29		6		34		6		35		33

Pilot:

A/C:



CIVA Advanced

Programme3

WAAC

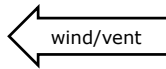

R

Figure K

339

Total K

369

Judges Name	
Signature	
Number	

Flight #
V

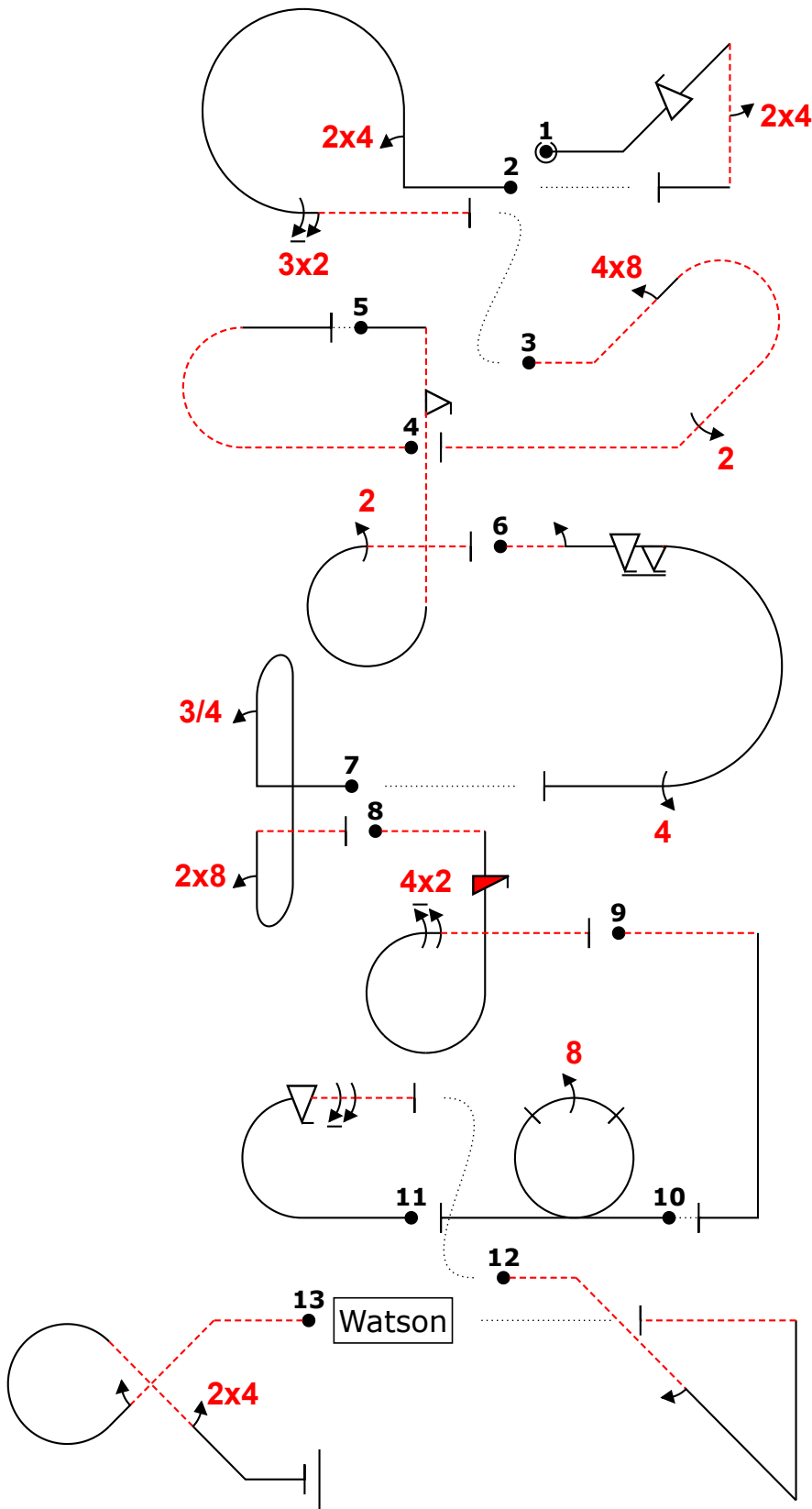

Fig	Grade	Pos	Remarks
1	.		
2	.		
3	.		
4	.		
5	.		
6	.		
7	.		
8	.		
9	.		
10	.		
11	.		
12	.		
13	.		

Positioning	30	.
-------------	----	---

Too Low		Trg Violation	
Too High		Wing Rocks	
Interruptions		Disqual Fig	
Insertions		Other(note...)	

Fig 1 E	K	Fig 2 G	K	Fig 3 A	K	Fig 4 L	K	Fig 5 D	K	Fig 6 B	K	Fig 7 H	K	Fig 8 F	K	Fig 9 L	K	Fig 10 J	K	Fig 11 C	K	Fig 12 L	K	Fig 13 I	K
1.2.1.1	13	8.6.2.1	12	8.4.15.2	16	7.2.1.2	8	8.6.3.3	13	7.2.1.4	6	8.8.1.1	18	8.6.1.4	12	1.1.7.4	9	7.4.1.1	10	7.2.1.1	6	1.2.3.4	12	7.3.4.4	15
9.9.2.4	13	9.4.1.2	9	9.8.2.2	9			9.9.10.2	13	9.1.3.2	4	9.1.1.3	10	9.12.1.4	7			9.8.3.4	15	9.9.3.4	11	9.1.4.2	4	9.1.4.2	4
9.4.5.2	5	9.2.3.6	12	9.2.4.4	9			9.2.3.4	9	9.9.3.6	14	9.8.1.1	7	9.2.3.8	15					9.1.3.8	12			9.4.4.2	5
	31		33		34		8		35		35		35		34		8		25		29		8		24

Pilot: Dave Watson

A/C: MX2 n451EE

Team: IND



CIVA Advanced

Programme3

WAAC

Figure K

339

Total K

369

Judges Name	
Signature	
Number	

Flight #
V

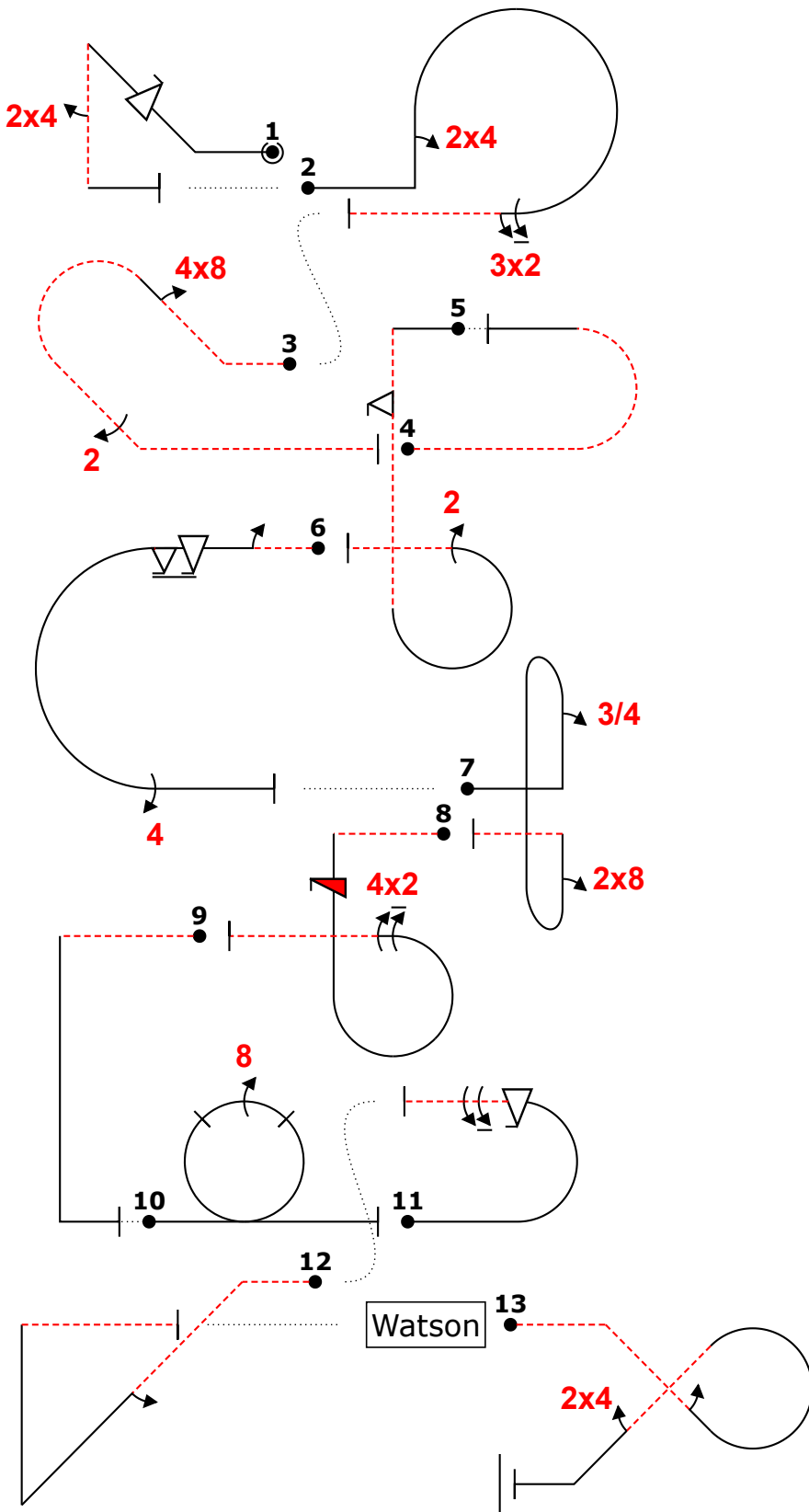
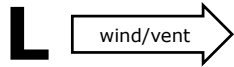

Fig	Grade	Pos	Remarks
1	.		
2	.		
3	.		
4	.		
5	.		
6	.		
7	.		
8	.		
9	.		
10	.		
11	.		
12	.		
13	.		

Positioning	30	.
-------------	----	---

Too Low		Trg Violation	
Too High		Wing Rocks	
Interruptions		Disqual Fig	
Insertions		Other(note...)	

Fig 1 E	K	Fig 2 G	K	Fig 3 A	K	Fig 4 L	K	Fig 5 D	K	Fig 6 B	K	Fig 7 H	K	Fig 8 F	K	Fig 9 L	K	Fig 10 J	K	Fig 11 C	K	Fig 12 L	K	Fig 13 I	K
1.2.1.1	13	8.6.2.1	12	8.4.15.2	16	7.2.1.2	8	8.6.3.3	13	7.2.1.4	6	8.8.1.1	18	8.6.1.4	12	1.1.7.4	9	7.4.1.1	10	7.2.1.1	6	1.2.3.4	12	7.3.4.4	15
9.9.2.4	13	9.4.1.2	9	9.8.2.2	9			9.9.10.2	13	9.1.3.2	4	9.1.1.3	10	9.12.1.4	7			9.8.3.4	15	9.9.3.4	11	9.1.4.2	4	9.1.4.2	4
9.4.5.2	5	9.2.3.6	12	9.2.4.4	9			9.2.3.4	9	9.9.3.6	14	9.8.1.1	7	9.2.3.8	15					9.1.3.8	12			9.4.4.2	5
	31		33		34		8		35		35		35		34		8		25		29		8		24

Pilot: Dave Watson

A/C: MX2 n451EE

Team: IND