

Sequence A Corrected

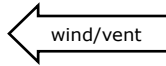

CIVA Advanced

Programme4



R

Figure K

344

Total K

374

Judges Name

Flight #

Signature

Number

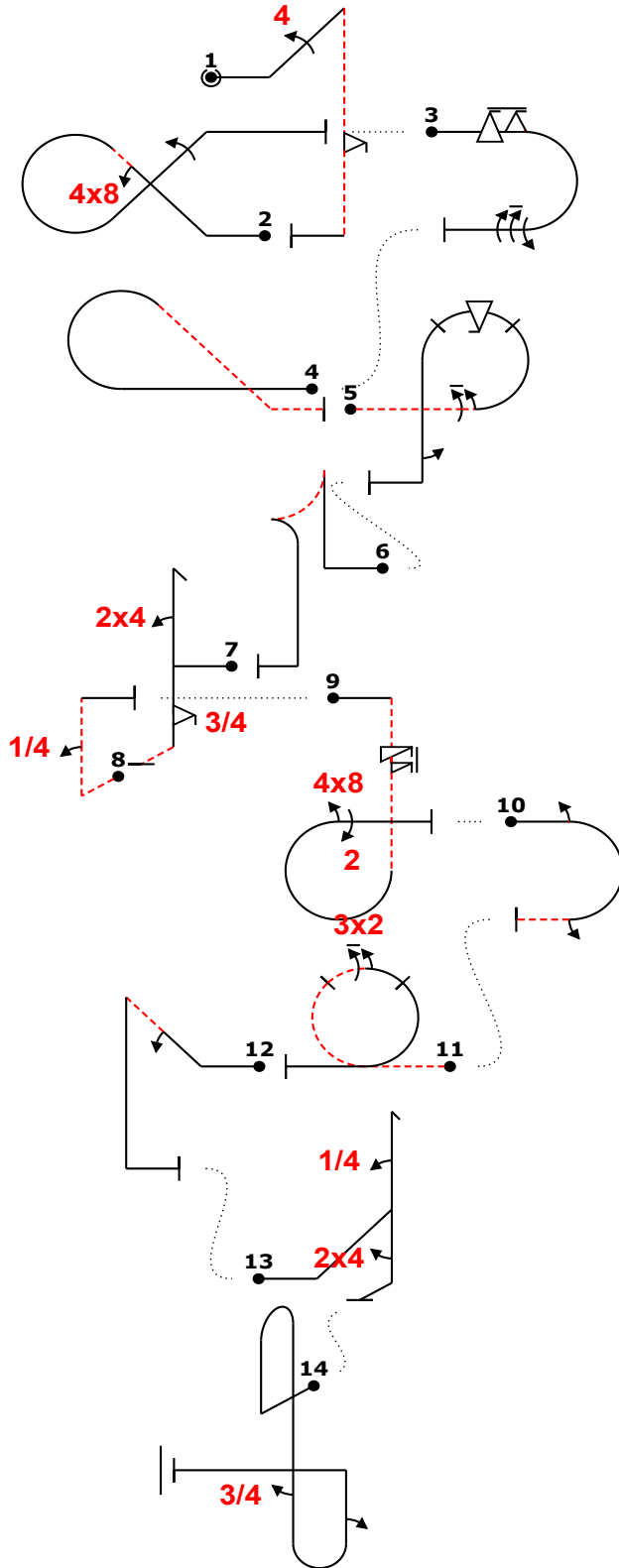

Fig	Grade	Pos	Remarks
1	.		
2	.		
3	.		
4	.		
5	.		
6	.		
7	.		
8	.		
9	.		
10	.		
11	.		
12	.		
13	.		
14	.		

Positioning	30	.
-------------	----	---

Too Low		Trg Violation	
Too High		Wing Rocks	
Interruptions		Disqual Fig	
Insertions		Other(note...)	

Fig 1 C	K	Fig 2 E	K	Fig 3 A	K	Fig 4 L	K	Fig 5 D	K	Fig 6 J	K	Fig 7 B	K	Fig 8 L	K	Fig 9 I	K	Fig 10 L	K	Fig 11 H	K	Fig 12 L	K	Fig 13 F	K	Fig 14 G	K
1.2.1.1	13	7.3.2.1	14	7.2.3.3	6	8.5.5.1	10	8.6.7.2	12	6.2.2.1	15	5.2.1.3	18	1.1.7.2	12	8.6.4.3	13	7.2.4.3	6	7.4.2.2	12	1.2.3.1	12	5.3.1.1	18	8.8.2.1	19
9.4.2.4	13	9.8.2.2	9	9.9.3.6	14			9.1.3.6	10			9.4.1.2	9	9.1.1.1	6	9.1.1.6	3	9.1.3.2	4	9.2.3.6	12	9.1.2.2	6	9.1.1.1	6	9.1.5.3	6
9.9.10.2	13	9.1.2.4	10	9.1.3.4	8			9.9.3.4	11			9.9.5.3	11			9.8.3.2	7	9.1.3.2	4					9.4.5.2	5	9.1.1.2	8
				9.1.3.8	12			9.1.5.2	4							9.2.3.4	9										
	39		33		40		6		37		15		38		6		32		6		24		6		29		33

Pilot:

A/C:

Team: BRA

Sequence A Corrected



CIVA Advanced

Programme4

Figure K

344

Total K

374

Judges Name	
Signature	Number

Flight #

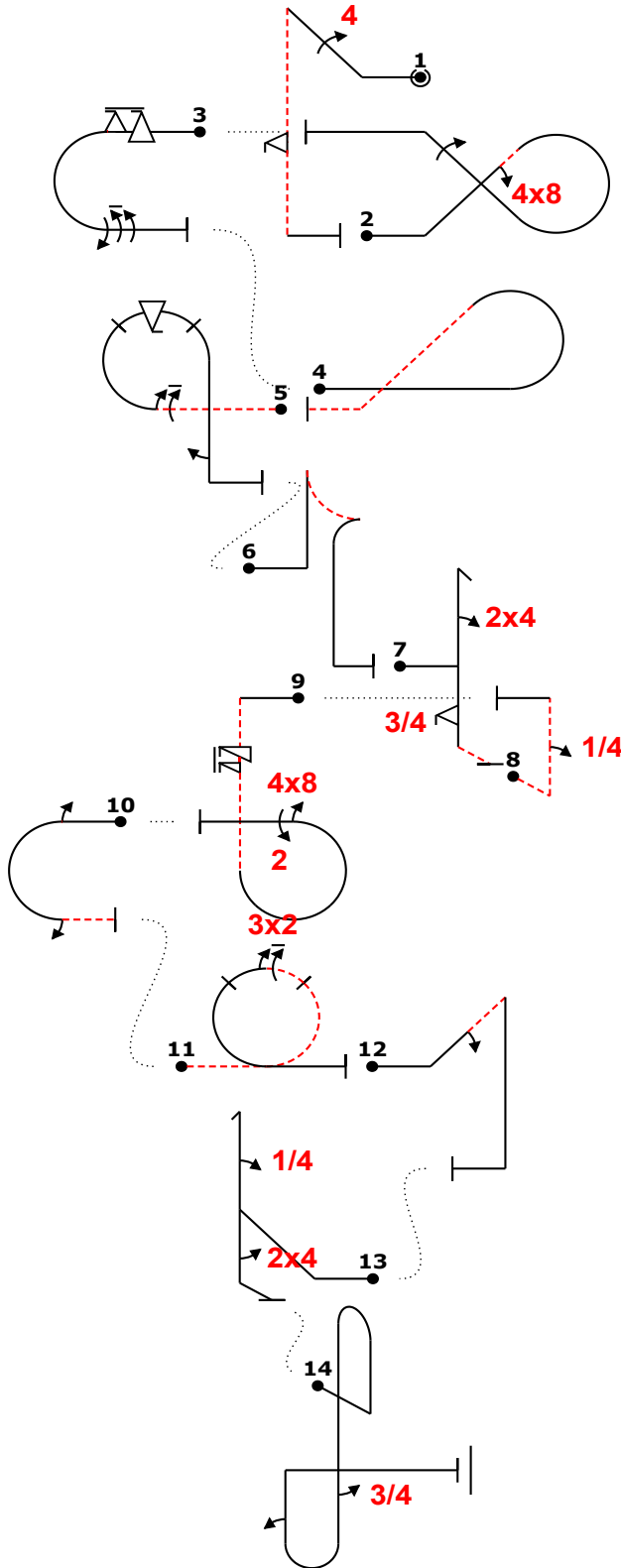
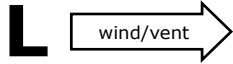

Fig	Grade	Pos	Remarks
1	.		
2	.		
3	.		
4	.		
5	.		
6	.		
7	.		
8	.		
9	.		
10	.		
11	.		
12	.		
13	.		
14	.		

Positioning	30	.
-------------	----	---

Too Low		Trg Violation	
Too High		Wing Rocks	
Interruptions		Disqual Fig	
Insertions		Other(note...)	

Fig 1 C	K	Fig 2 E	K	Fig 3 A	K	Fig 4 L	K	Fig 5 D	K	Fig 6 J	K	Fig 7 B	K	Fig 8 L	K	Fig 9 I	K	Fig 10 L	K	Fig 11 H	K	Fig 12 L	K	Fig 13 F	K	Fig 14 G	K
1.2.1.1	13	7.3.2.1	14	7.2.3.3	6	8.5.5.1	10	8.6.7.2	12	6.2.2.1	15	5.2.1.3	18	1.1.7.2	12	8.6.4.3	13	7.2.4.3	6	7.4.2.2	12	1.2.3.1	12	5.3.1.1	18	8.8.2.1	19
9.4.2.4	13	9.8.2.2	9	9.9.3.6	14			9.1.3.6	10			9.4.1.2	9	9.1.1.1	6	9.1.1.6	3	9.1.3.2	4	9.2.3.6	12	9.1.2.2	6	9.1.1.1	6	9.1.5.3	6
9.9.10.2	13	9.1.2.4	10	9.1.3.4	8			9.9.3.4	11			9.9.5.3	11			9.8.3.2	7	9.1.3.2	4					9.4.5.2	5	9.1.1.2	8
				9.1.3.8	12			9.1.5.2	4							9.2.3.4	9										
	39		33		40		6		37		15		38		6		32		6		24		6		29		33

Pilot:

A/C:

Team: BRA

Sequence A



CIVA	Advanced
Programme3	

Figure K
339
Total K
369

Judges Name	
Signature	Number

Flight #

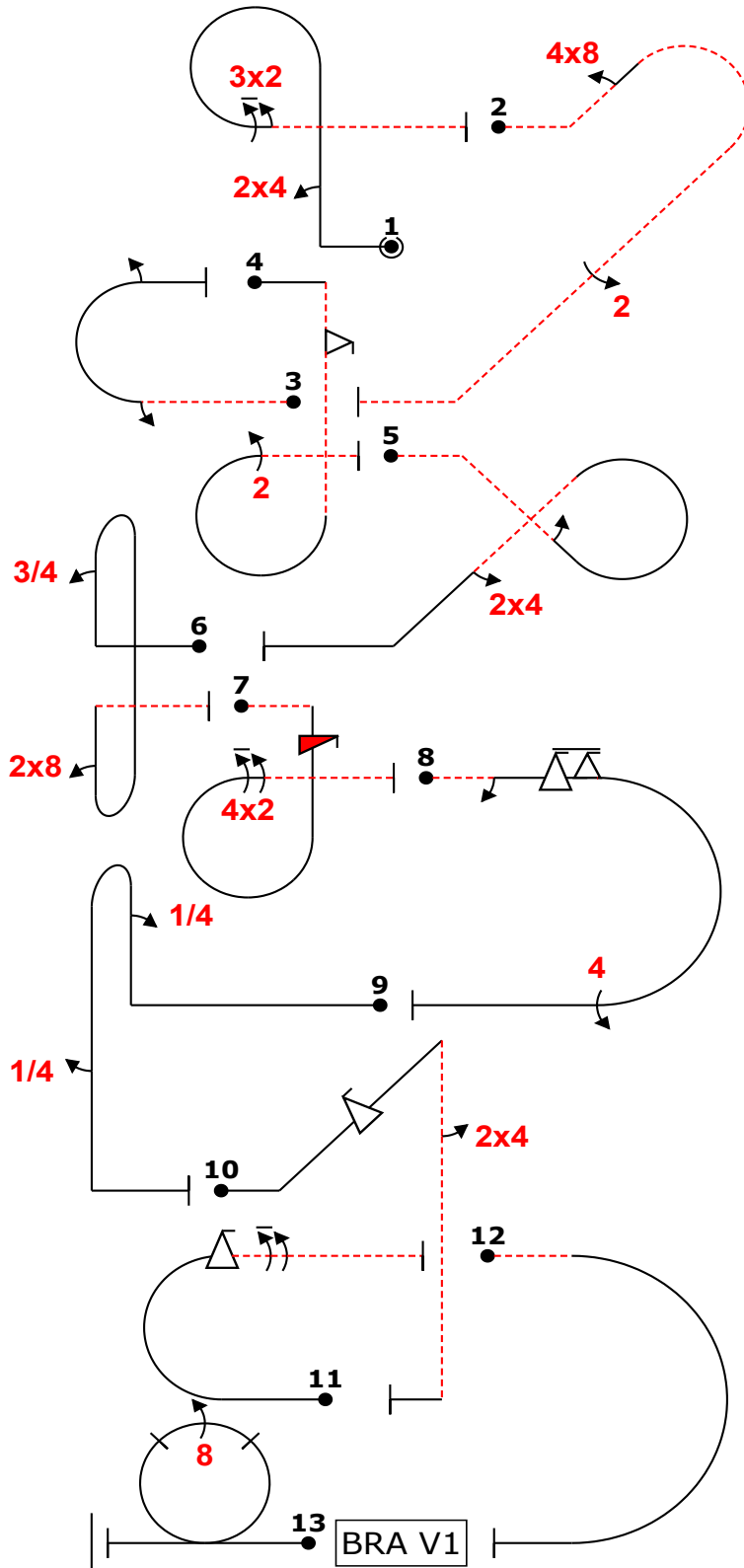

Fig	Grade	Pos	Remarks
1	.		
2	.		
3	.		
4	.		
5	.		
6	.		
7	.		
8	.		
9	.		
10	.		
11	.		
12	.		
13	.		

Positioning
30

Too Low		Trg Violation	
Too High		Wing Rocks	
Interruptions		Disqual Fig	
Insertions		Other(note...)	

Fig 1 G	K	Fig 2 A	K	Fig 3 L	K	Fig 4 D	K	Fig 5 I	K	Fig 6 H	K	Fig 7 F	K	Fig 8 B	K	Fig 9 L	K	Fig 10 E	K	Fig 11 C	K	Fig 12 L	K	Fig 13 J	K
8.6.2.1	12	8.4.15.2	16	7.2.4.2	6	8.6.3.3	13	7.3.4.4	15	8.8.1.1	18	8.6.1.4	12	7.2.1.4	6	8.4.1.1	13	1.2.1.1	13	7.2.1.1	6	7.2.1.4	6	7.4.1.1	10
9.4.1.2	9	9.8.2.2	9	9.1.3.2	4	9.9.10.2	13	9.1.4.2	4	9.1.1.3	10	9.12.1.4	7	9.1.3.2	4	9.1.1.1	6	9.9.2.4	13	9.9.3.4	11			9.8.3.4	15
9.2.3.6	12	9.2.4.4	9	9.1.3.2	4	9.2.3.4	9	9.4.4.2	5	9.8.1.1	7	9.2.3.8	15	9.9.3.6	14	9.1.5.1	2	9.4.5.2	5	9.1.3.8	12				
	33		34		8		35		24		35		34		35		8		31		29		8		25

Pilot:

A/C:

Team: **BRA**

Sequence A



CIVA Advanced

Programme3

Figure K

339

Total K

369

Judges Name		Flight #
Signature	Number	

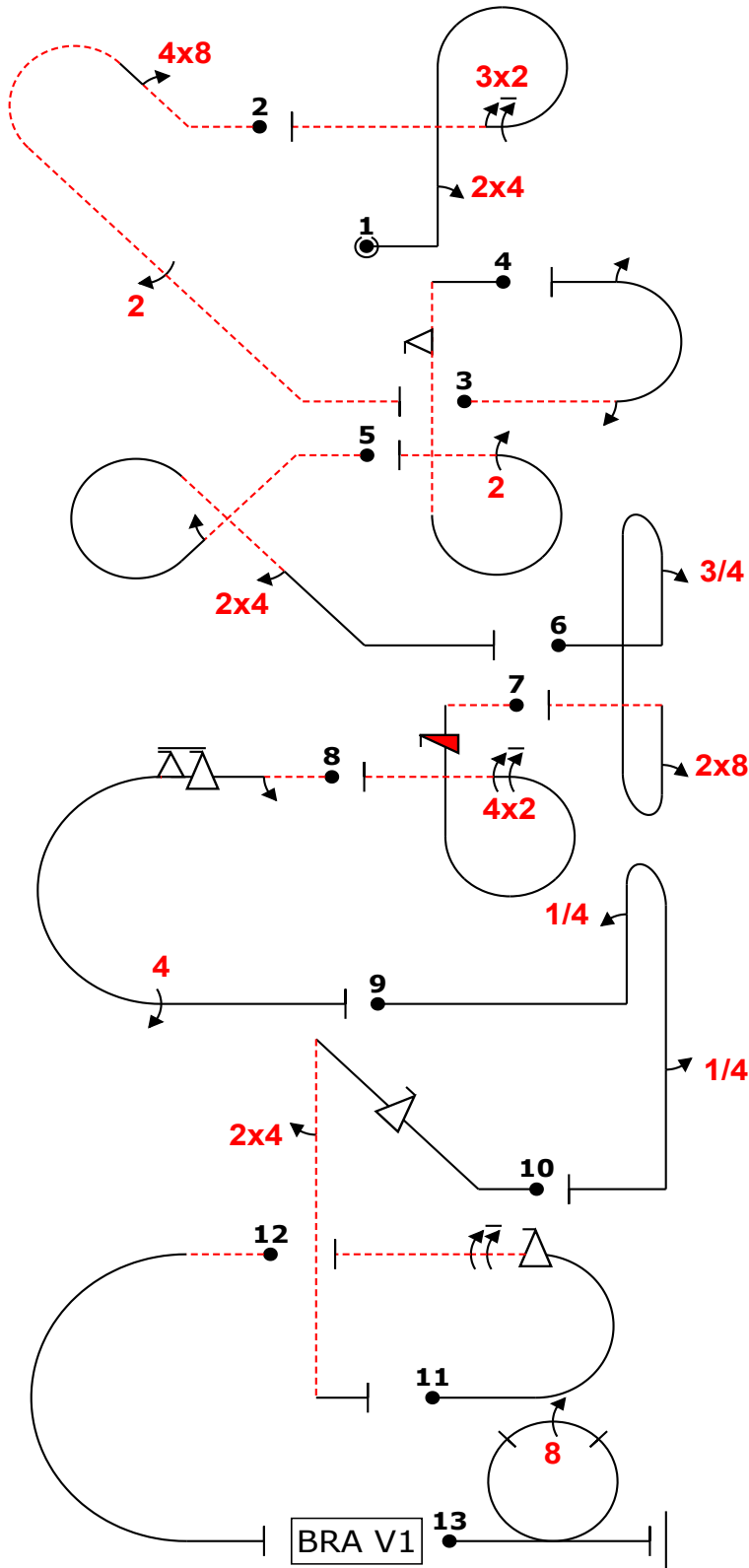
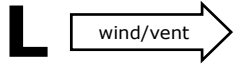

Fig	Grade	Pos	Remarks
1	.		
2	.		
3	.		
4	.		
5	.		
6	.		
7	.		
8	.		
9	.		
10	.		
11	.		
12	.		
13	.		

Positioning	30	.
-------------	----	---

Too Low		Trg Violation	
Too High		Wing Rocks	
Interruptions		Disqual Fig	
Insertions		Other(note...)	

Fig 1 G	K	Fig 2 A	K	Fig 3 L	K	Fig 4 D	K	Fig 5 I	K	Fig 6 H	K	Fig 7 F	K	Fig 8 B	K	Fig 9 L	K	Fig 10 E	K	Fig 11 C	K	Fig 12 L	K	Fig 13 J	K
8.6.2.1	12	8.4.15.2	16	7.2.4.2	6	8.6.3.3	13	7.3.4.4	15	8.8.1.1	18	8.6.1.4	12	7.2.1.4	6	8.4.1.1	13	1.2.1.1	13	7.2.1.1	6	7.2.1.4	6	7.4.1.1	10
9.4.1.2	9	9.8.2.2	9	9.1.3.2	4	9.9.10.2	13	9.1.4.2	4	9.1.1.3	10	9.12.1.4	7	9.1.3.2	4	9.1.1.1	6	9.9.2.4	13	9.9.3.4	11			9.8.3.4	15
9.2.3.6	12	9.2.4.4	9	9.1.3.2	4	9.2.3.4	9	9.4.4.2	5	9.8.1.1	7	9.2.3.8	15	9.9.3.6	14	9.1.5.1	2	9.4.5.2	5	9.1.3.8	12				
	33		34		8		35		24		35		34		35		8		31		29		8		25

Pilot:

A/C:

Team: BRA

Sequence B



CIVA Advanced 10/29/2023
 Programme4 WAAC 2023

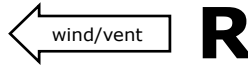

Figure K
344
 Total K
374

Judges Name		Flight #
Signature	Number	

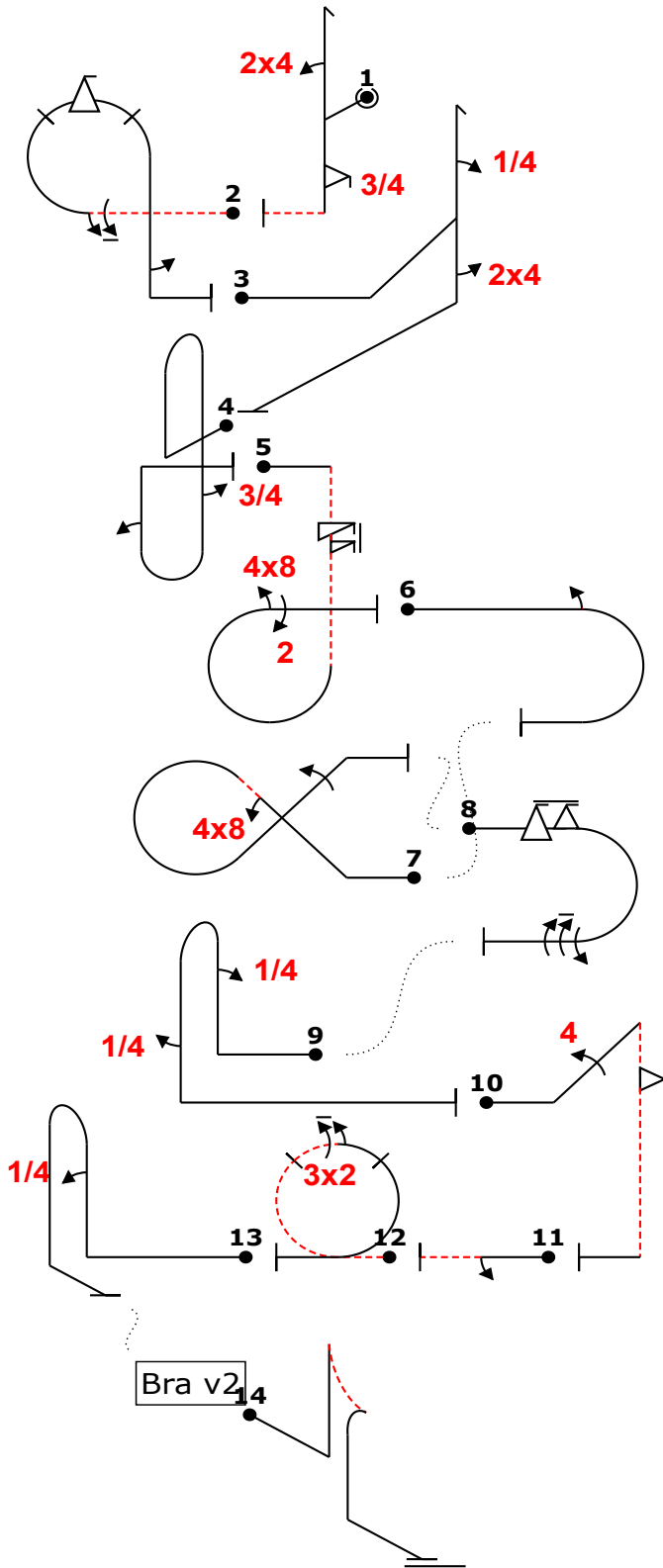

Fig	Grade	Pos	Remarks
1	.		
2	.		
3	.		
4	.		
5	.		
6	.		
7	.		
8	.		
9	.		
10	.		
11	.		
12	.		
13	.		
14	.		

Positioning
30

Too Low		Trg Violation	
Too High		Wing Rocks	
Interruptions		Disqual Fig	
Insertions		Other(note...)	

Fig 1 B	K	Fig 2 D	K	Fig 3 F	K	Fig 4 G	K	Fig 5 I	K	Fig 6 L	K	Fig 7 E	K	Fig 8 A	K	Fig 9 L	K	Fig 10 C	K	Fig 11 L	K	Fig 12 H	K	Fig 13 L	K	Fig 14 J	K
5.2.1.3	18	8.6.7.2	12	5.3.1.1	18	8.8.2.1	19	8.6.4.3	13	7.2.3.3	6	7.3.2.1	14	7.2.3.3	6	8.4.1.1	13	1.2.1.1	13	1.1.1.3	2	7.4.2.2	12	8.4.1.1	13	6.2.2.1	15
9.4.1.2	9	9.1.3.6	10	9.1.1.1	6	9.1.5.3	6	9.1.1.6	3	9.1.3.2	4	9.8.2.2	9	9.9.3.6	14	9.1.1.1	6	9.4.2.4	13	9.1.3.2	4	9.2.3.6	12	9.1.1.1	6		
9.9.5.3	11	9.9.3.4	11	9.4.5.2	5	9.1.1.2	8	9.8.3.2	7	9.2.3.4	9	9.1.2.4	10	9.1.3.4	8	9.1.5.1	2	9.9.10.2	13								
	38		37		29		33		32		6		33		40		6		39		6		24		6		15

Pilot:

A/C:

Team: **BRA**

Sequence B



CIVA Advanced 10/29/2023
 Programme4 WAAC 2023

Figure K
344
 Total K
374

Judges Name	
Signature	Number

Flight #

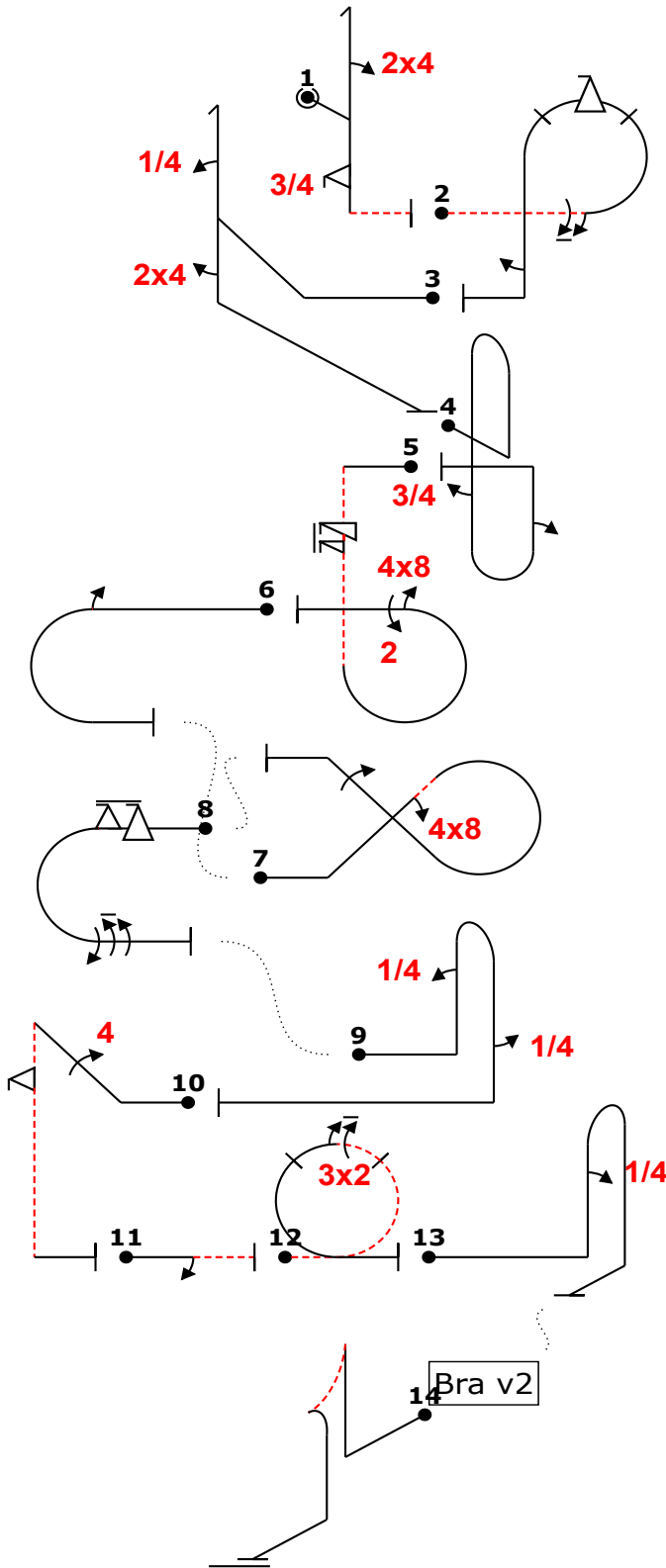
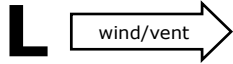

Fig	Grade	Pos	Remarks
1	.		
2	.		
3	.		
4	.		
5	.		
6	.		
7	.		
8	.		
9	.		
10	.		
11	.		
12	.		
13	.		
14	.		

Positioning
30

Too Low		Trg Violation	
Too High		Wing Rocks	
Interruptions		Disqual Fig	
Insertions		Other(note...)	

Fig 1 B	K	Fig 2 D	K	Fig 3 F	K	Fig 4 G	K	Fig 5 I	K	Fig 6 L	K	Fig 7 E	K	Fig 8 A	K	Fig 9 L	K	Fig 10 C	K	Fig 11 L	K	Fig 12 H	K	Fig 13 L	K	Fig 14 J	K
5.2.1.3	18	8.6.7.2	12	5.3.1.1	18	8.8.2.1	19	8.6.4.3	13	7.2.3.3	6	7.3.2.1	14	7.2.3.3	6	8.4.1.1	13	1.2.1.1	13	1.1.1.3	2	7.4.2.2	12	8.4.1.1	13	6.2.2.1	15
9.4.1.2	9	9.1.3.6	10	9.1.1.1	6	9.1.5.3	6	9.1.1.6	3	9.1.3.2	4	9.8.2.2	9	9.9.3.6	14	9.1.1.1	6	9.4.2.4	13	9.1.3.2	4	9.2.3.6	12	9.1.1.1	6		
9.9.5.3	11	9.9.3.4	11	9.4.5.2	5	9.1.1.2	8	9.8.3.2	7	9.2.3.4	9	9.1.2.4	10	9.1.3.4	8	9.1.5.1	2	9.9.10.2	13								
		9.1.5.2	4											9.1.3.8	12												
	38		37		29		33		32		6		33		40		6		39		6		24		6		15

Pilot:

A/C:

Team: **BRA**

Sequence C



CIVA Advanced

Programme4

Figure K

344

Total K

374

Judges Name		Flight #
Signature	Number	

wind/vent **R**

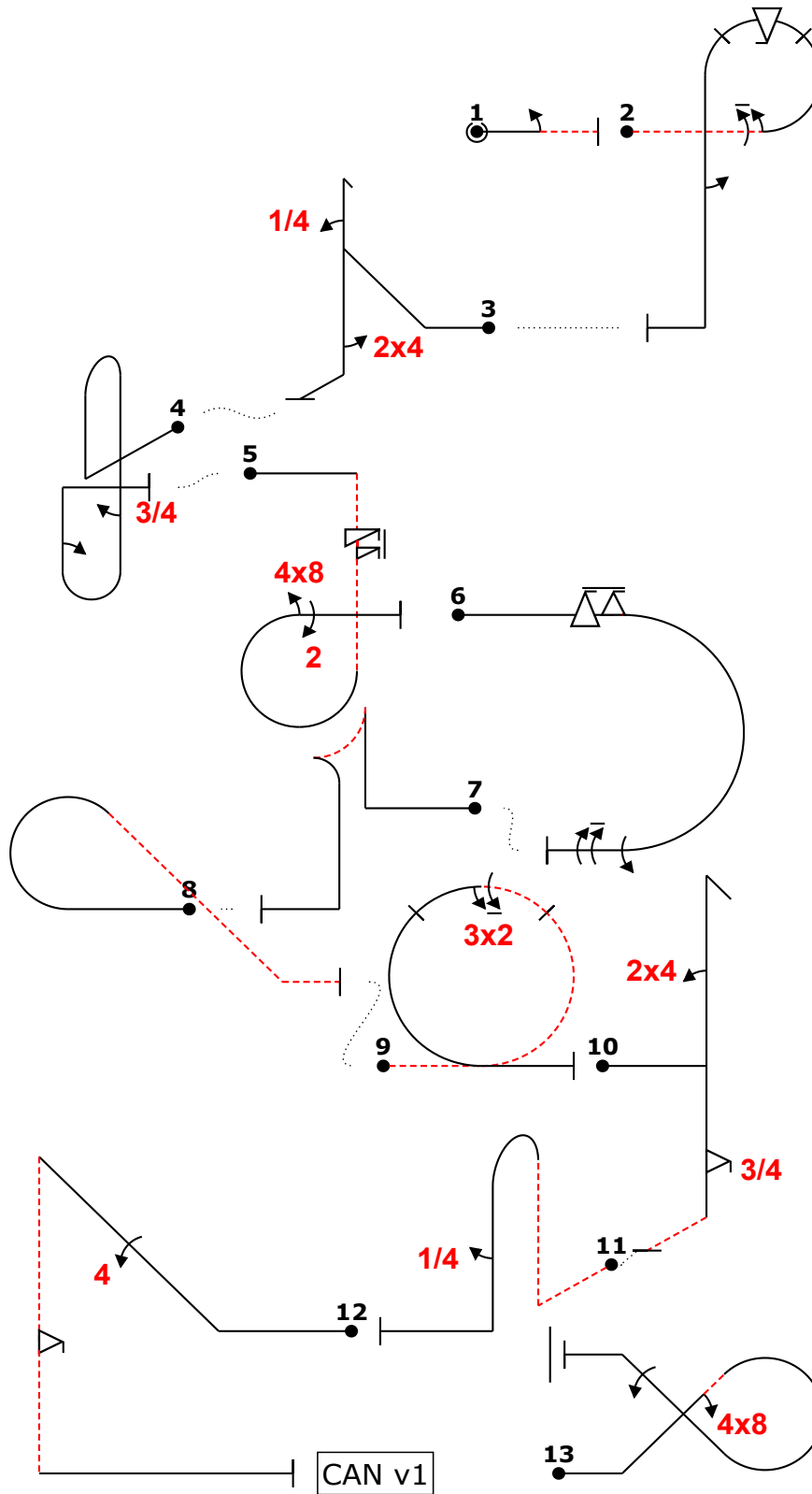

Fig	Grade	Pos	Remarks
1	.		
2	.		
3	.		
4	.		
5	.		
6	.		
7	.		
8	.		
9	.		
10	.		
11	.		
12	.		
13	.		

Positioning	.
30	

Too Low		Trg Violation	
Too High		Wing Rocks	
Interruptions		Disqual Fig	
Insertions		Other(note...)	

Fig 1 L	K	Fig 2 D	K	Fig 3 F	K	Fig 4 G	K	Fig 5 I	K	Fig 6 A	K	Fig 7 J	K	Fig 8 L	K	Fig 9 H	K	Fig 10 B	K	Fig 11 L	K	Fig 12 C	K	Fig 13 E	K
1.1.1.3	2	8.6.7.2	12	5.3.1.1	18	8.8.2.1	19	8.6.4.3	13	7.2.3.3	6	6.2.2.1	15	8.5.5.1	10	7.4.2.2	12	5.2.1.3	18	8.4.4.2	14	1.2.1.1	13	7.3.2.1	14
9.1.3.2	4	9.1.3.6	10	9.1.1.1	6	9.1.5.3	6	9.1.1.6	3	9.9.3.6	14					9.2.3.6	12	9.4.1.2	9	9.1.5.1	2	9.4.2.4	13	9.8.2.2	9
		9.9.3.4	11	9.4.5.2	5	9.1.1.2	8	9.8.3.2	7	9.1.3.4	8							9.9.5.3	11			9.9.10.2	13	9.1.2.4	10
		9.1.5.2	4					9.2.3.4	9	9.1.3.8	12														
	8		37		29		33		32		40		15		8		24		38		8		39		33

Pilot:

A/C:

Sequence C



CIVA Advanced

Programme4

Figure K

344

Total K

374

Judges Name		Flight #
Signature	Number	

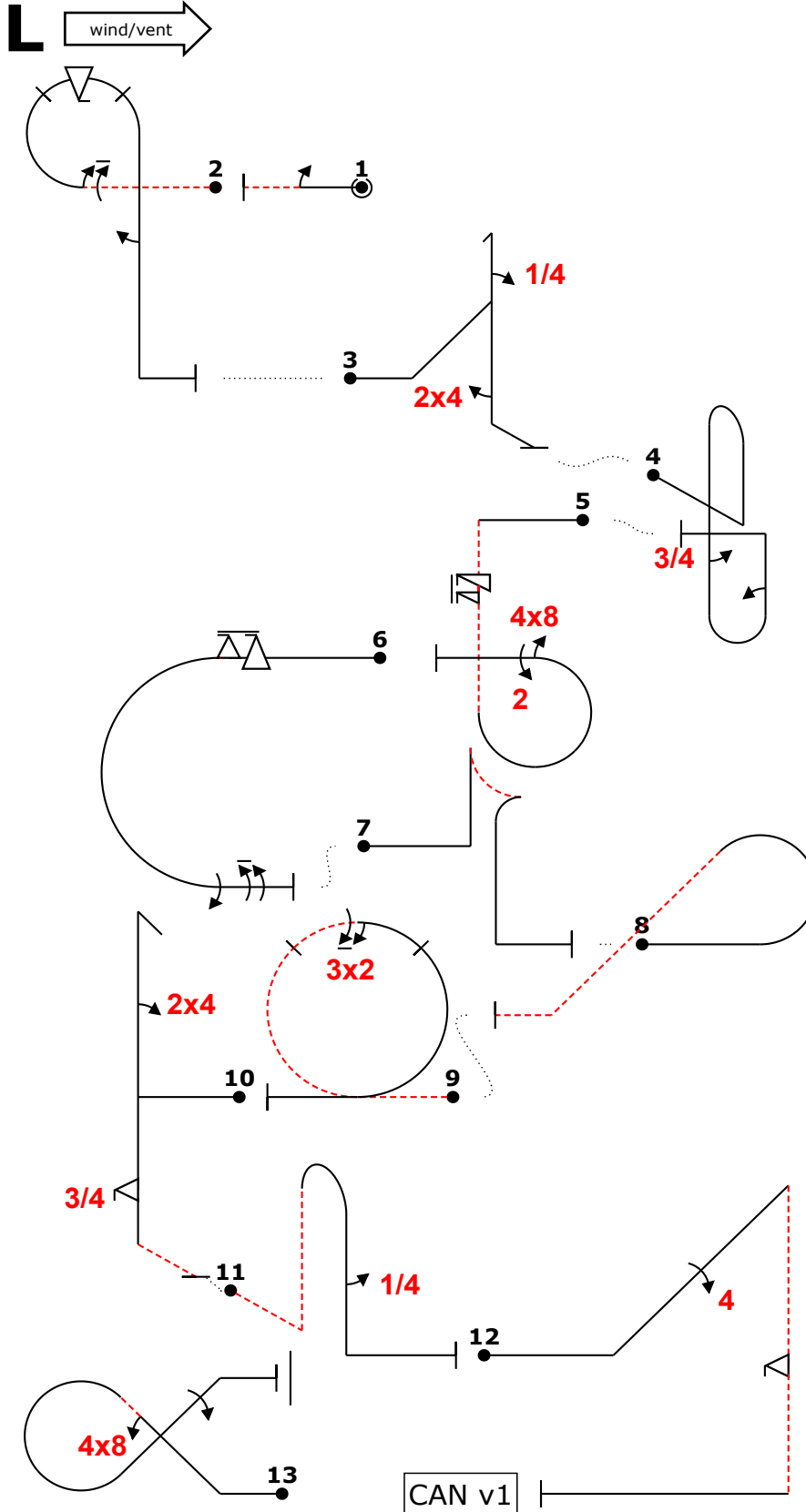

Fig	Grade	Pos	Remarks
1	.		
2	.		
3	.		
4	.		
5	.		
6	.		
7	.		
8	.		
9	.		
10	.		
11	.		
12	.		
13	.		

Positioning	
30	.

Too Low		Trg Violation	
Too High		Wing Rocks	
Interruptions		Disqual Fig	
Insertions		Other(note...)	

Fig 1 L	K	Fig 2 D	K	Fig 3 F	K	Fig 4 G	K	Fig 5 I	K	Fig 6 A	K	Fig 7 J	K	Fig 8 L	K	Fig 9 H	K	Fig 10 B	K	Fig 11 L	K	Fig 12 C	K	Fig 13 E	K
1.1.1.3	2	8.6.7.2	12	5.3.1.1	18	8.8.2.1	19	8.6.4.3	13	7.2.3.3	6	6.2.2.1	15	8.5.5.1	10	7.4.2.2	12	5.2.1.3	18	8.4.4.2	14	1.2.1.1	13	7.3.2.1	14
9.1.3.2	4	9.1.3.6	10	9.1.1.1	6	9.1.5.3	6	9.1.1.6	3	9.9.3.6	14					9.2.3.6	12	9.4.1.2	9	9.1.5.1	2	9.4.2.4	13	9.8.2.2	9
		9.9.3.4	11	9.4.5.2	5	9.1.1.2	8	9.8.3.2	7	9.1.3.4	8							9.9.5.3	11			9.9.10.2	13	9.1.2.4	10
		9.1.5.2	4					9.2.3.4	9	9.1.3.8	12														
	8		37		29		33		32		40		15		8		24		38		8		39		33

Pilot:

A/C:

Sequence D



CIVA Advanced 10/29/2023
 Programme4 WAAC 2023

Figure K
344
 Total K
374

Judges Name		Flight #
Signature	Number	

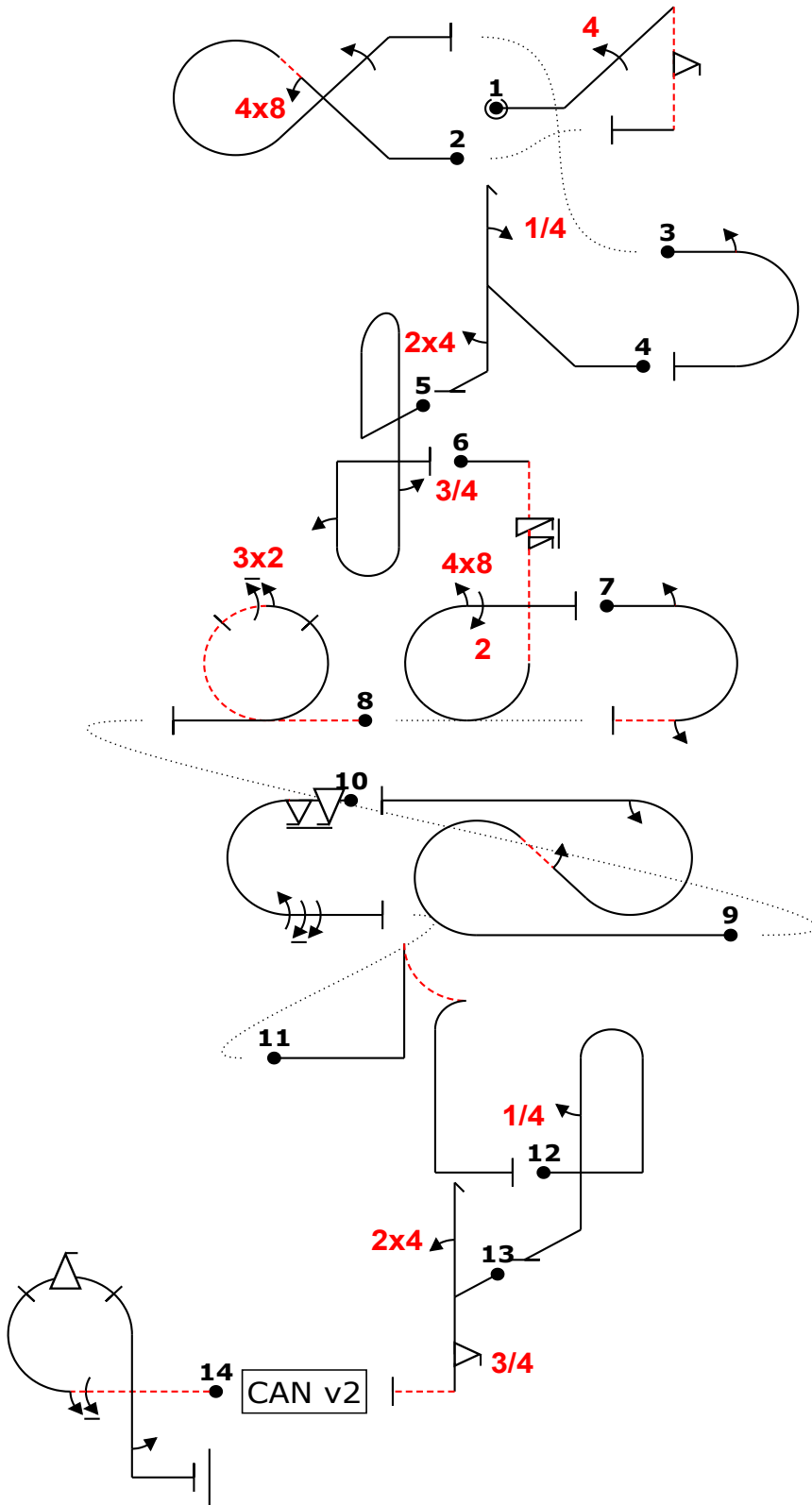
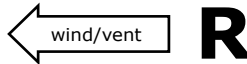

Fig	Grade	Pos	Remarks
1	.		
2	.		
3	.		
4	.		
5	.		
6	.		
7	.		
8	.		
9	.		
10	.		
11	.		
12	.		
13	.		
14	.		

Positioning
30 .

Too Low		Trg Violation	
Too High		Wing Rocks	
Interruptions		Disqual Fig	
Insertions		Other(note...)	

Fig 1 C	K	Fig 2 E	K	Fig 3 L	K	Fig 4 F	K	Fig 5 G	K	Fig 6 I	K	Fig 7 L	K	Fig 8 H	K	Fig 9 L	K	Fig 10 A	K	Fig 11 J	K	Fig 12 L	K	Fig 13 B	K	Fig 14 D	K
1.2.1.1	13	7.3.2.1	14	7.2.3.3	6	5.3.1.1	18	8.8.2.1	19	8.6.4.3	13	7.2.4.3	6	7.4.2.2	12	7.5.7.1	15	7.2.3.3	6	6.2.2.1	15	8.4.1.1	13	5.2.1.3	18	8.6.7.2	12
9.4.2.4	13	9.8.2.2	9	9.1.3.2	4	9.1.1.1	6	9.1.5.3	6	9.1.1.6	3	9.1.3.2	4	9.2.3.6	12	9.1.4.2	4	9.9.3.6	14			9.1.5.1	2	9.4.1.2	9	9.1.3.6	10
9.9.10.2	13	9.1.2.4	10			9.4.5.2	5	9.1.1.2	8	9.8.3.2	7	9.1.3.2	4			9.1.3.2	4	9.1.3.4	8					9.9.5.3	11	9.9.3.4	11
								9.2.3.4	9									9.1.3.8	12							9.1.5.2	4
	39		33		6		29		33		32		6		24		6		40		15		6		38		37

Pilot:

A/C:

Sequence D



CIVA Advanced 10/29/2023
 Programme4 WAAC 2023

Figure K
344
 Total K
374

Judges Name		Flight #
Signature	Number	

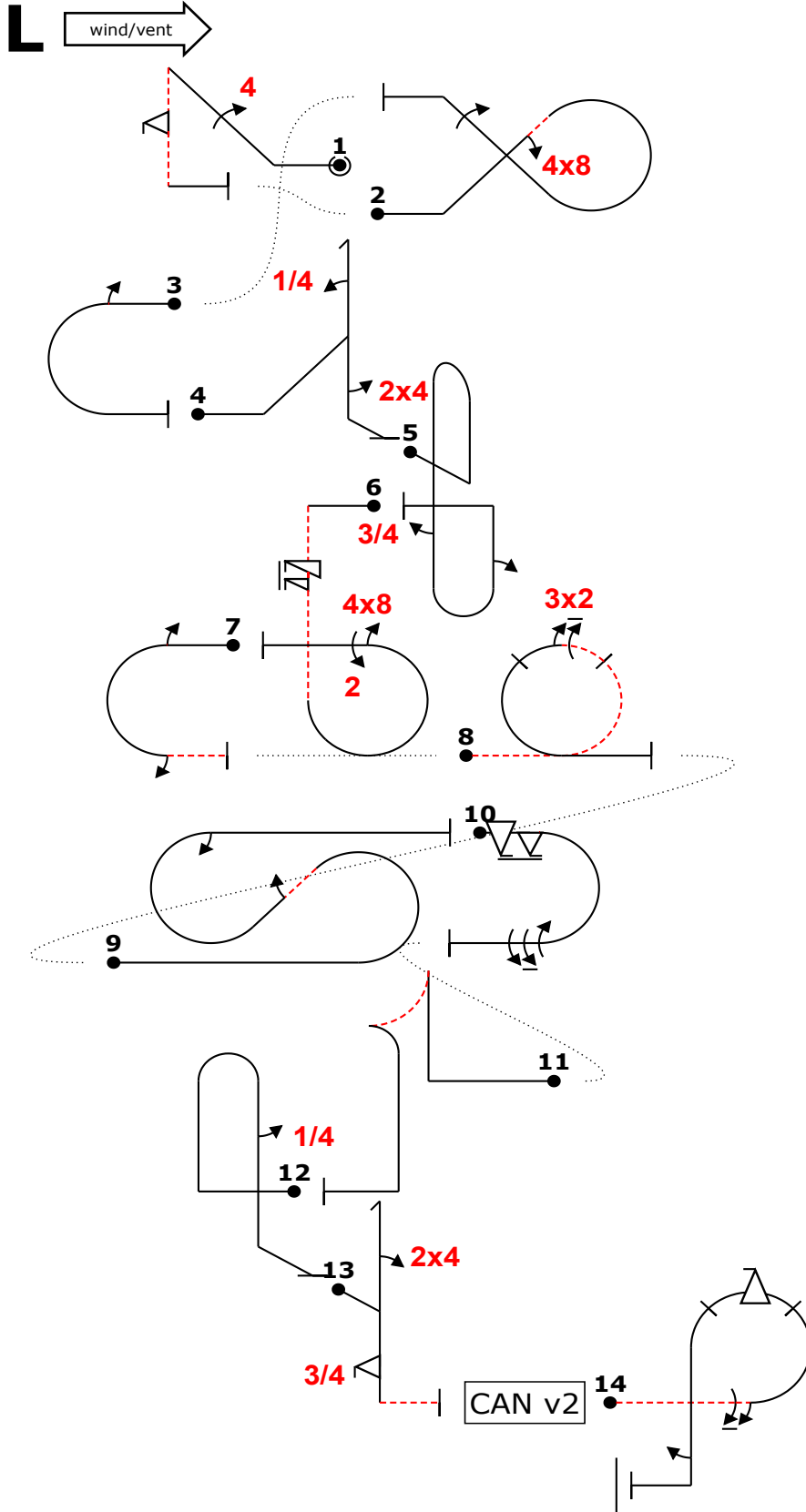

Fig	Grade	Pos	Remarks
1	.		
2	.		
3	.		
4	.		
5	.		
6	.		
7	.		
8	.		
9	.		
10	.		
11	.		
12	.		
13	.		
14	.		

Positioning
30 .

Too Low		Trg Violation	
Too High		Wing Rocks	
Interruptions		Disqual Fig	
Insertions		Other(note...)	

Fig 1 C	K	Fig 2 E	K	Fig 3 L	K	Fig 4 F	K	Fig 5 G	K	Fig 6 I	K	Fig 7 L	K	Fig 8 H	K	Fig 9 L	K	Fig 10 A	K	Fig 11 J	K	Fig 12 L	K	Fig 13 B	K	Fig 14 D	K
1.2.1.1	13	7.3.2.1	14	7.2.3.3	6	5.3.1.1	18	8.8.2.1	19	8.6.4.3	13	7.2.4.3	6	7.4.2.2	12	7.5.7.1	15	7.2.3.3	6	6.2.2.1	15	8.4.1.1	13	5.2.1.3	18	8.6.7.2	12
9.4.2.4	13	9.8.2.2	9	9.1.3.2	4	9.1.1.1	6	9.1.5.3	6	9.1.1.6	3	9.1.3.2	4	9.2.3.6	12	9.1.4.2	4	9.9.3.6	14			9.1.5.1	2	9.4.1.2	9	9.1.3.6	10
9.9.10.2	13	9.1.2.4	10			9.4.5.2	5	9.1.1.2	8	9.8.3.2	7	9.1.3.2	4			9.1.3.2	4	9.1.3.4	8					9.9.5.3	11	9.9.3.4	11
								9.2.3.4	9							9.1.3.8	12									9.1.5.2	4
	39		33		6		29		33		32		6		24		6		40		15		6		38		37

Pilot:

A/C:

Sequence E



CIVA Advanced 10/29/2023
 Programme4 WAAC 2023

Figure K
344
 Total K
374

Judges Name		Flight #
Signature	Number	

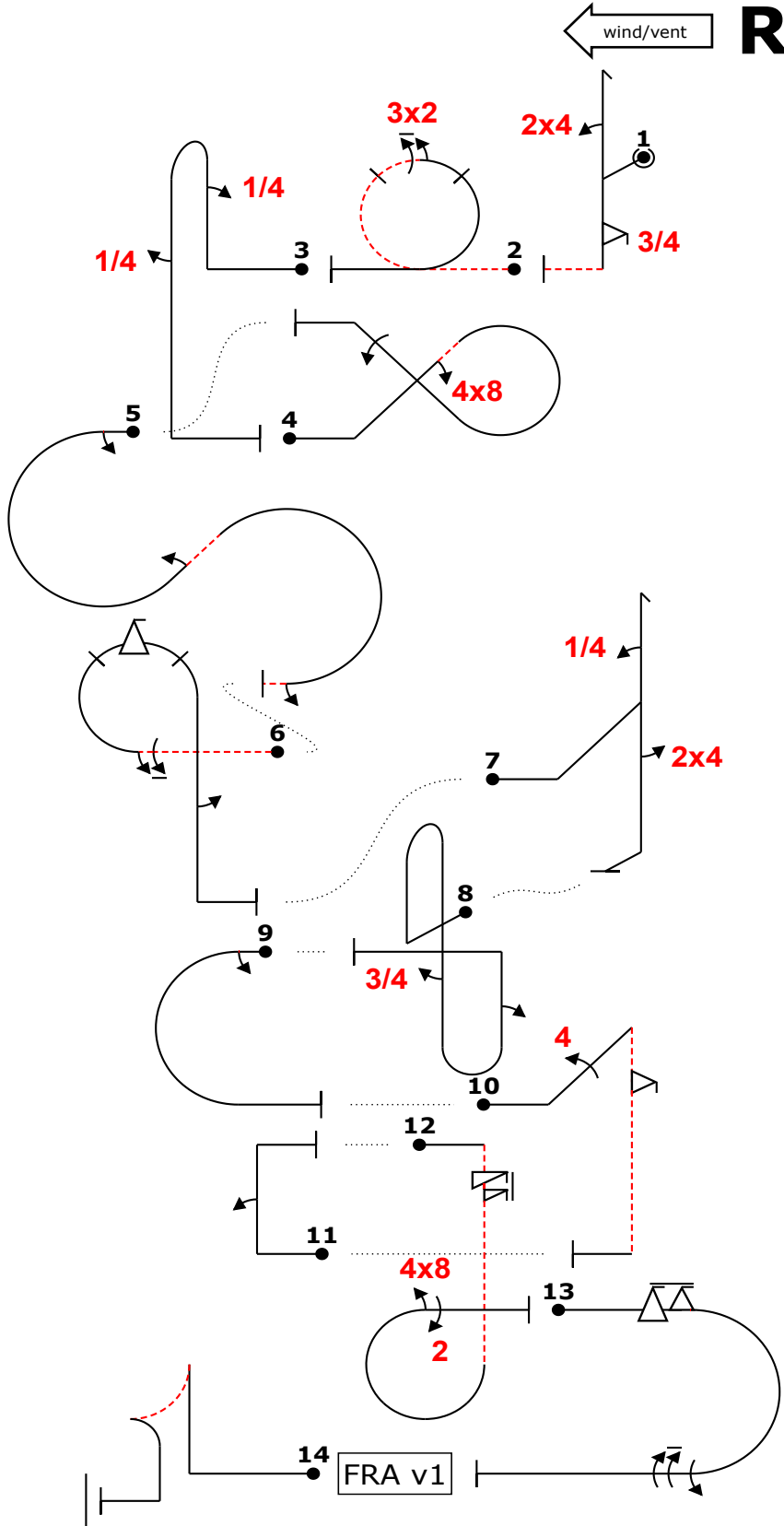

Fig	Grade	Pos	Remarks
1	.		
2	.		
3	.		
4	.		
5	.		
6	.		
7	.		
8	.		
9	.		
10	.		
11	.		
12	.		
13	.		
14	.		

Positioning
30

Too Low		Trg Violation	
Too High		Wing Rocks	
Interruptions		Disqual Fig	
Insertions		Other(note...)	

Fig	B	K	Fig	H	K	Fig	L	K	Fig	E	K	Fig	L	K	Fig	D	K	Fig	F	K	Fig	G	K	Fig	L	K	Fig	C	K	Fig	L	K	Fig	I	K	Fig	A	K	Fig	J	K		
5.2.1.3	18		7.4.2.2	12		8.4.1.1	13		7.3.2.1	14		7.5.8.3	15		8.6.7.2	12		5.3.1.1	18		8.8.2.1	19		7.2.3.3	6		1.2.1.1	13		1.1.6.1	10		8.6.4.3	13		7.2.3.3	6		6.2.2.1	15			
9.4.1.2	9		9.2.3.6	12		9.1.1.1	6		9.8.2.2	9		9.1.3.2	4		9.1.3.6	10		9.1.1.1	6		9.1.5.3	6		9.1.3.2	4		9.4.2.4	13		9.1.1.2	8		9.1.1.6	3		9.9.3.6	14						
9.9.5.3	11					9.1.5.1	2		9.1.2.4	10		9.1.2.2	6		9.9.3.4	11		9.4.5.2	5		9.1.1.2	8					9.9.10.2	13					9.8.3.2	7		9.1.3.4	8		9.1.3.4	9		9.1.3.8	12
	38			24			6			33			6			37			29			33			6			39			6			32			40			15			

Pilot:

A/C:

Sequence F



CIVA Advanced 10/29/2023
 Programme4 WAAC 2023

Figure K
344
 Total K
374

Judges Name
 Signature Number

Flight #

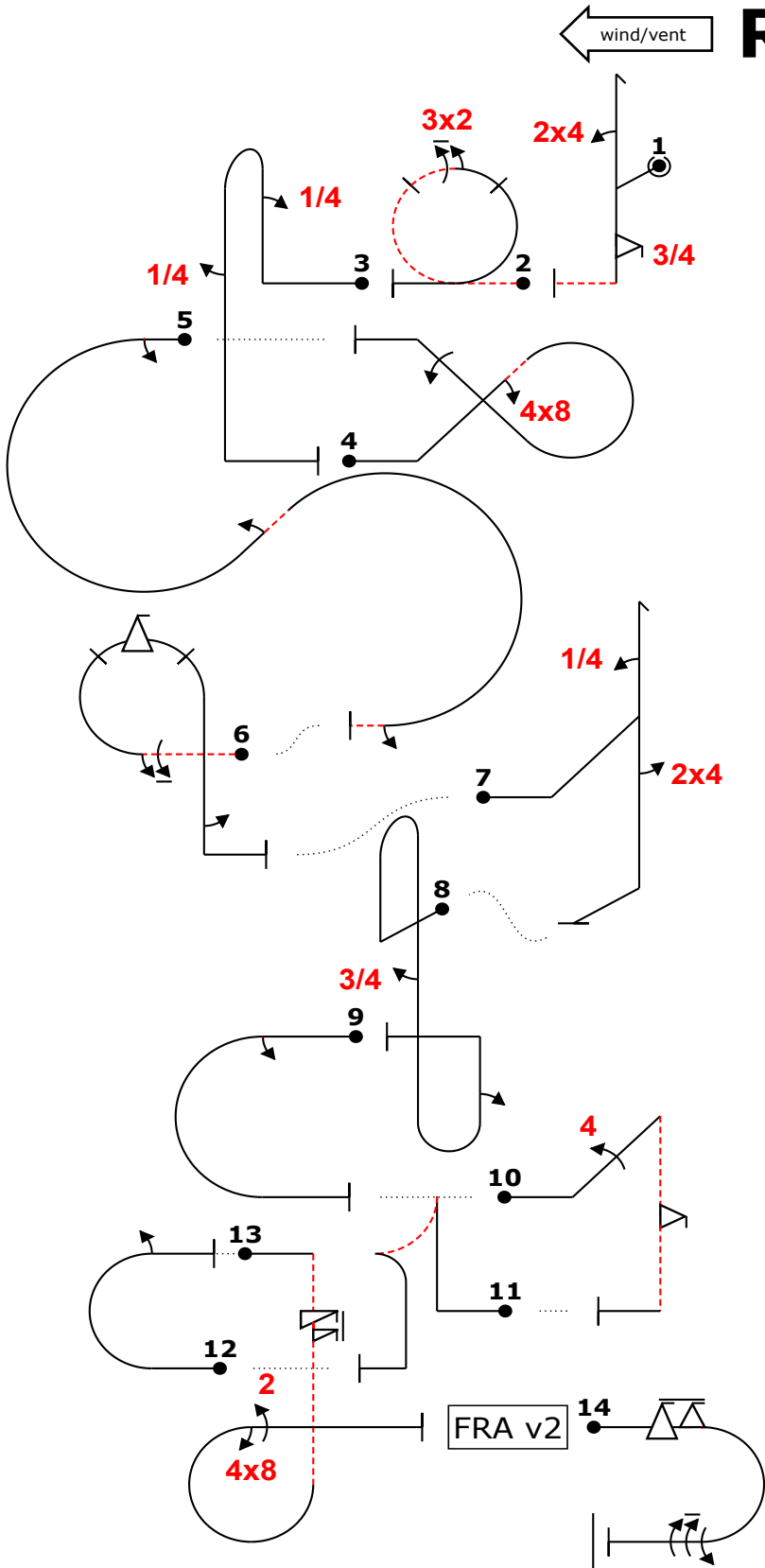

Fig	Grade	Pos	Remarks
1	.		
2	.		
3	.		
4	.		
5	.		
6	.		
7	.		
8	.		
9	.		
10	.		
11	.		
12	.		
13	.		
14	.		

Positioning
30

Too Low		Trg Violation	
Too High		Wing Rocks	
Interruptions		Disqual Fig	
Insertions		Other(note...)	

Fig 1 B	K	Fig 2 H	K	Fig 3 L	K	Fig 4 E	K	Fig 5 L	K	Fig 6 D	K	Fig 7 F	K	Fig 8 G	K	Fig 9 L	K	Fig 10 C	K	Fig 11 J	K	Fig 12 L	K	Fig 13 I	K	Fig 14 A	K
5.2.1.3	18	7.4.2.2	12	8.4.1.1	13	7.3.2.1	14	7.5.8.3	15	8.6.7.2	12	5.3.1.1	18	8.8.2.1	19	7.2.3.3	6	1.2.1.1	13	6.2.2.1	15	7.2.2.1	6	8.6.4.3	13	7.2.3.3	6
9.4.1.2	9	9.2.3.6	12	9.1.1.1	6	9.8.2.2	9	9.1.3.2	4	9.1.3.6	10	9.1.1.1	6	9.1.5.3	6	9.1.3.2	4	9.4.2.4	13			9.1.3.2	4	9.11.1.6	3	9.9.3.6	14
9.9.5.3	11			9.1.5.1	2	9.1.2.4	10	9.1.2.2	6	9.9.3.4	11	9.4.5.2	5	9.1.1.2	8	9.9.10.2	13							9.8.3.2	7	9.1.3.4	8
								9.1.3.2	4	9.1.5.2	4											9.2.3.4	9	9.1.3.8	12		
	38		24		6		33		6		37		29		33		6		39		15		6		32		40

Pilot:

A/C:

Sequence F



CIVA Advanced 10/29/2023
 Programme4 WAAC 2023

Figure K
344
 Total K
374

Judges Name		Flight #
Signature	Number	

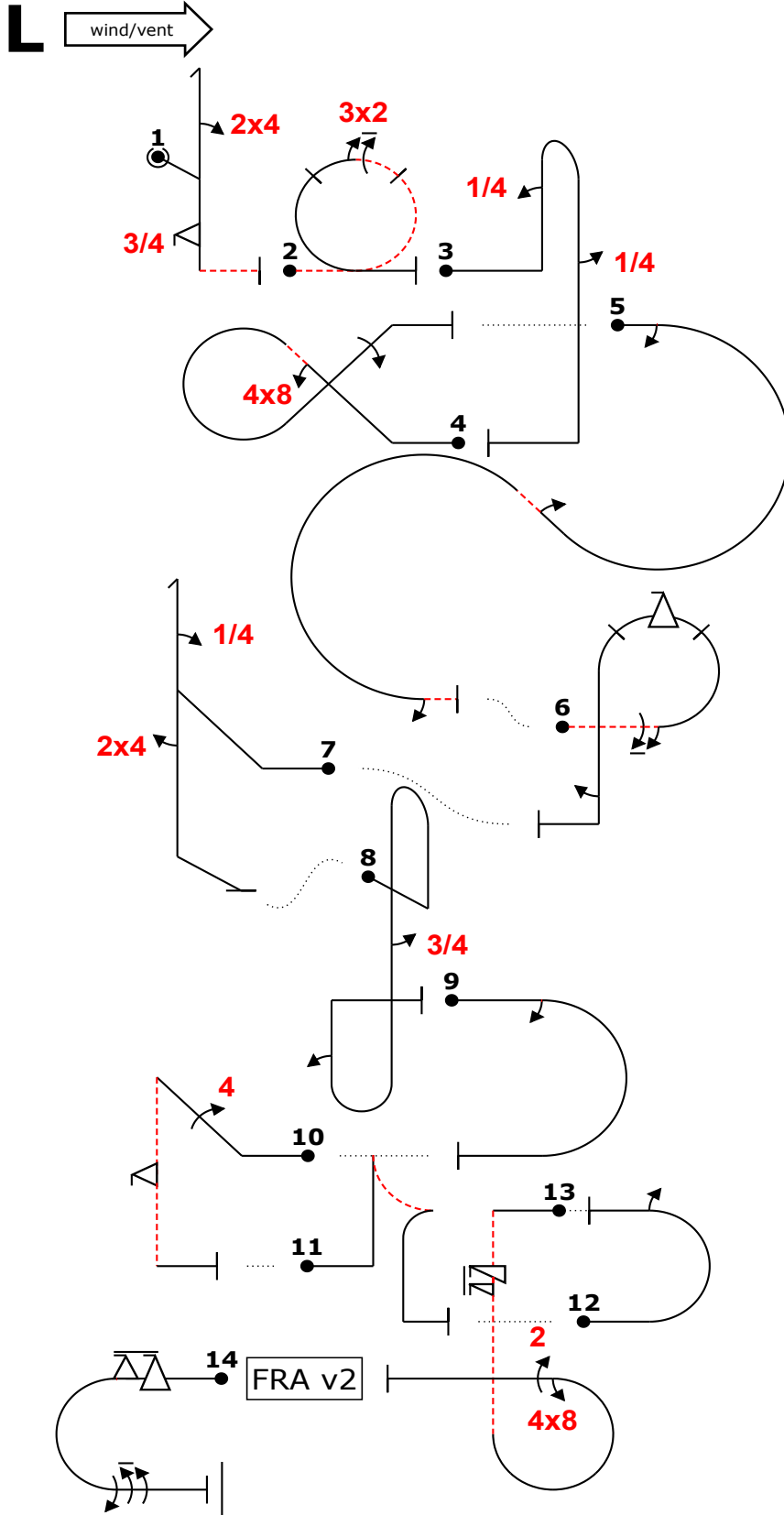

Fig	Grade	Pos	Remarks
1	.		
2	.		
3	.		
4	.		
5	.		
6	.		
7	.		
8	.		
9	.		
10	.		
11	.		
12	.		
13	.		
14	.		

Positioning
30 .

Too Low		Trg Violation	
Too High		Wing Rocks	
Interruptions		Disqual Fig	
Insertions		Other(note...)	

Fig 1 B	K	Fig 2 H	K	Fig 3 L	K	Fig 4 E	K	Fig 5 L	K	Fig 6 D	K	Fig 7 F	K	Fig 8 G	K	Fig 9 L	K	Fig 10 C	K	Fig 11 J	K	Fig 12 L	K	Fig 13 I	K	Fig 14 A	K
5.2.1.3	18	7.4.2.2	12	8.4.1.1	13	7.3.2.1	14	7.5.8.3	15	8.6.7.2	12	5.3.1.1	18	8.8.2.1	19	7.2.3.3	6	1.2.1.1	13	6.2.2.1	15	7.2.2.1	6	8.6.4.3	13	7.2.3.3	6
9.4.1.2	9	9.2.3.6	12	9.1.1.1	6	9.8.2.2	9	9.1.3.2	4	9.1.3.6	10	9.1.1.1	6	9.1.5.3	6	9.1.3.2	4	9.4.2.4	13			9.1.3.2	4	9.11.1.6	3	9.9.3.6	14
9.9.5.3	11			9.1.5.1	2	9.1.2.4	10	9.1.2.2	6	9.9.3.4	11	9.4.5.2	5	9.1.1.2	8			9.9.10.2	13					9.8.3.2	7	9.1.3.4	8
				9.1.3.2	4	9.1.5.2	4																	9.2.3.4	9	9.1.3.8	12
	38		24		6		33		6		37		29		33		6		39		15		6		32		40

Pilot:

A/C:

Sequence G



CIVA Advanced 10/29/2023
 Programme4 WAAC 2023

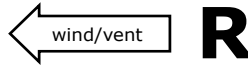

Figure K
344
 Total K
374

Judges Name		Flight #
Signature	Number	

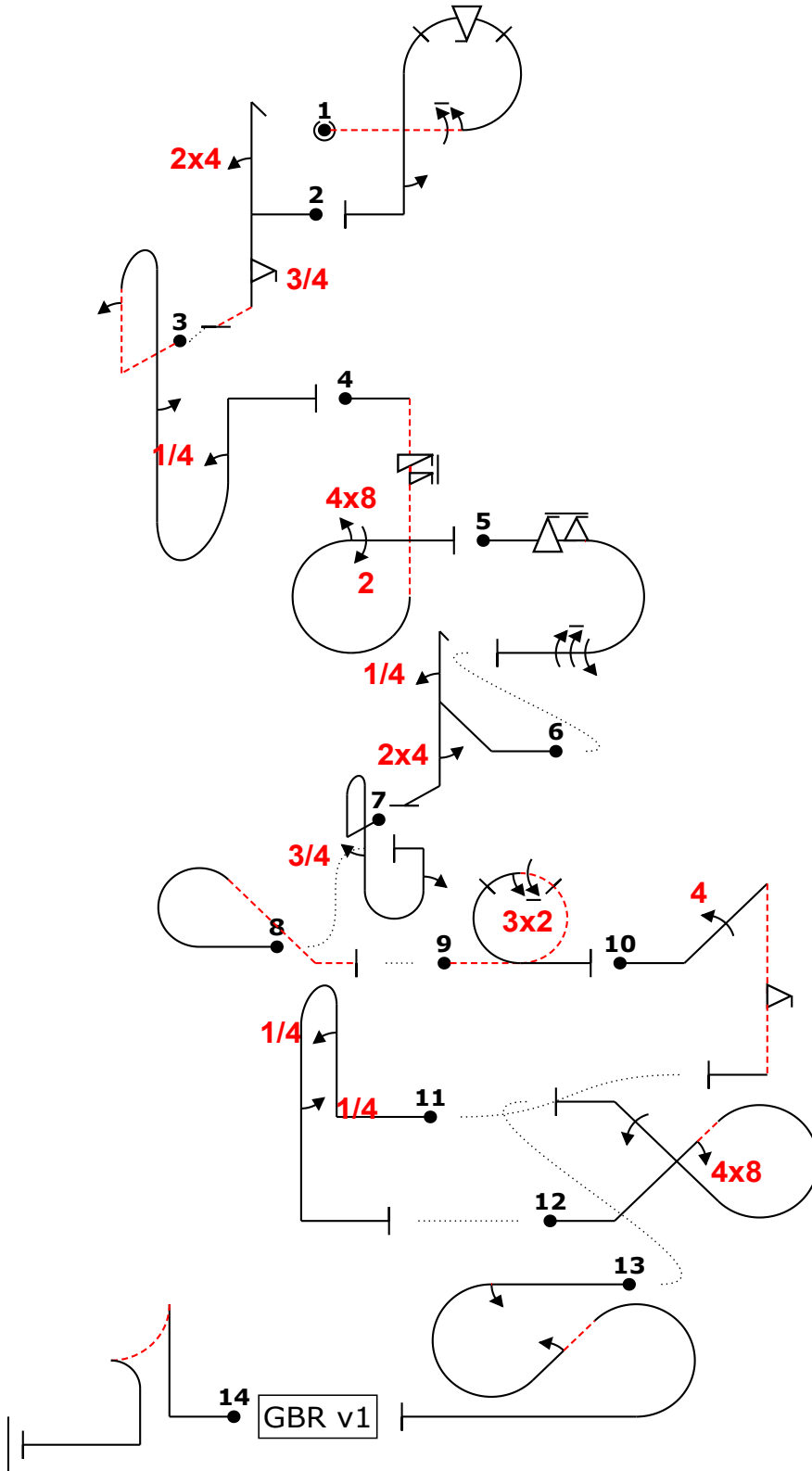

Fig	Grade	Pos	Remarks
1	.		
2	.		
3	.		
4	.		
5	.		
6	.		
7	.		
8	.		
9	.		
10	.		
11	.		
12	.		
13	.		
14	.		

Positioning
30 .

Too Low		Trg Violation	
Too High		Wing Rocks	
Interruptions		Disqual Fig	
Insertions		Other(note...)	

Fig	D	K	Fig	B	K	Fig	L	K	Fig	I	K	Fig	A	K	Fig	F	K	Fig	G	K	Fig	L	K	Fig	H	K	Fig	C	K	Fig	L	K	Fig	E	K	Fig	L	K	Fig	J	K
8.6.7.2	12	5.2.1.3	18	8.8.7.2	21	8.6.4.3	13	7.2.3.3	6	5.3.1.1	18	8.8.2.1	19	8.5.5.1	10	7.4.2.2	12	1.2.1.1	13	8.4.1.1	13	7.3.2.1	14	7.5.5.3	15	6.2.2.1	15														
9.1.3.6	10	9.4.1.2	9	9.1.1.2	8	9.1.1.6	3	9.9.3.6	14	9.1.1.1	6	9.1.5.3	6			9.2.3.6	12	9.4.2.4	13	9.1.1.1	6	9.8.2.2	9	9.1.3.2	4																
9.9.3.4	11	9.9.5.3	11	9.1.5.2	4	9.8.3.2	7	9.1.3.4	8	9.4.5.2	5	9.1.1.2	8					9.9.10.2	13	9.1.5.1	2	9.1.2.4	10	9.1.2.2	6																
9.1.5.2	4			9.1.1.1	6	9.2.3.4	9	9.1.3.8	12																																
	37		38		6		32		40		29		33		6		24		39		6		33		6		15														

Pilot:

A/C:

Sequence G



CIVA Advanced 10/29/2023
 Programme4 WAAC 2023

Figure K
344
 Total K
374

Judges Name		Flight #
Signature	Number	

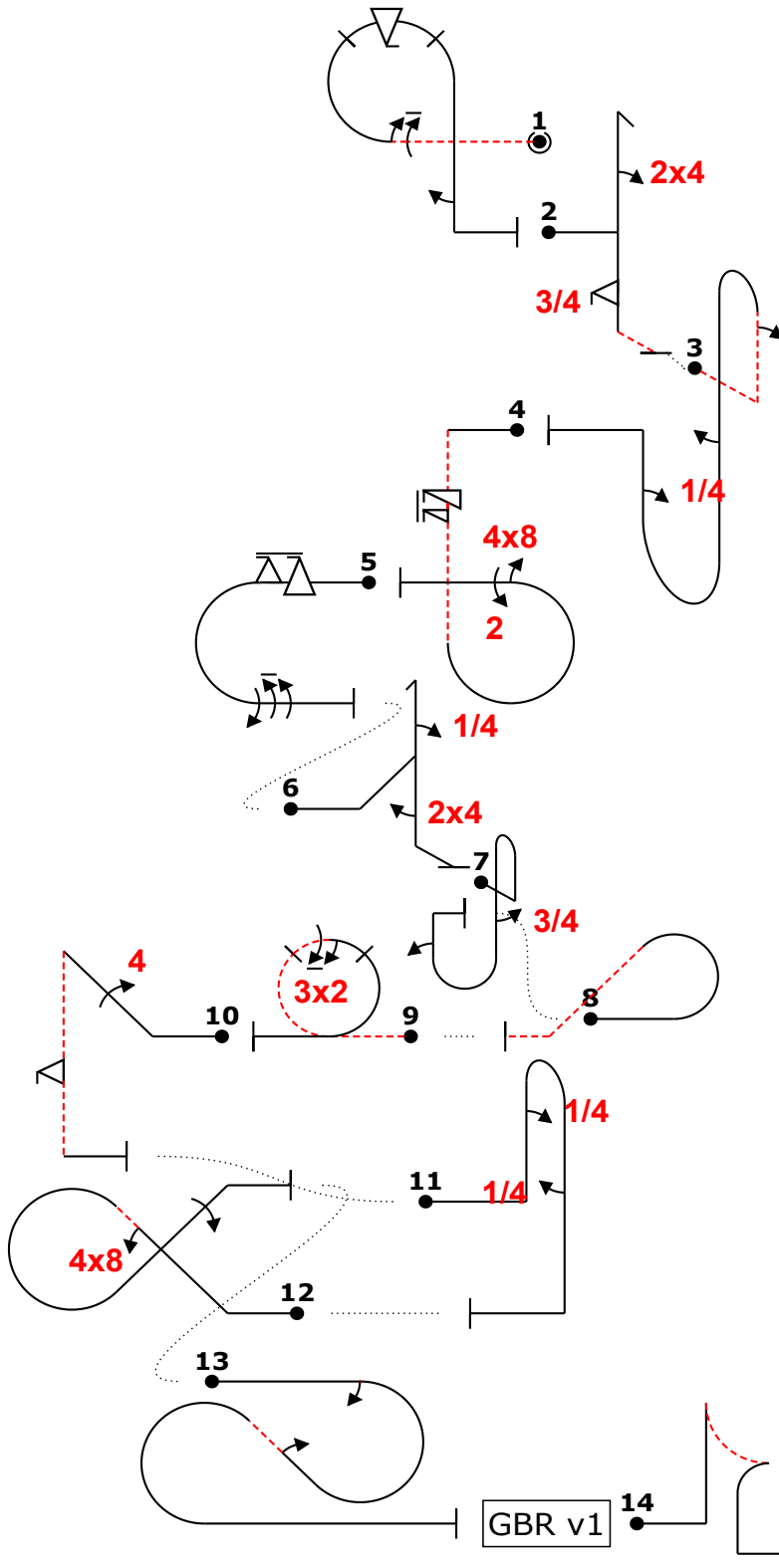
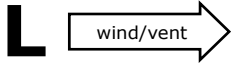

Fig	Grade	Pos	Remarks
1	.		
2	.		
3	.		
4	.		
5	.		
6	.		
7	.		
8	.		
9	.		
10	.		
11	.		
12	.		
13	.		
14	.		

Positioning
30

Too Low		Trg Violation	
Too High		Wing Rocks	
Interruptions		Disqual Fig	
Insertions		Other(note...)	

Fig 1 D	K	Fig 2 B	K	Fig 3 L	K	Fig 4 I	K	Fig 5 A	K	Fig 6 F	K	Fig 7 G	K	Fig 8 L	K	Fig 9 H	K	Fig 10 C	K	Fig 11 L	K	Fig 12 E	K	Fig 13 L	K	Fig 14 J	K
8.6.7.2	12	5.2.1.3	18	8.8.7.2	21	8.6.4.3	13	7.2.3.3	6	5.3.1.1	18	8.8.2.1	19	8.5.5.1	10	7.4.2.2	12	1.2.1.1	13	8.4.1.1	13	7.3.2.1	14	7.5.5.3	15	6.2.2.1	15
9.1.3.6	10	9.4.1.2	9	9.1.1.2	8	9.1.1.6	3	9.9.3.6	14	9.1.1.1	6	9.1.5.3	6			9.2.3.6	12	9.4.2.4	13	9.1.1.1	6	9.8.2.2	9	9.1.3.2	4		
9.9.3.4	11	9.9.5.3	11	9.1.5.2	4	9.8.3.2	7	9.1.3.4	8	9.4.5.2	5	9.1.1.2	8					9.9.10.2	13	9.1.5.1	2	9.1.2.4	10	9.1.2.2	6		
9.1.5.2	4			9.1.1.1	6	9.2.3.4	9	9.1.3.8	12																		
	37		38		6		32		40		29		33		6		24		39		6		33		6		15

Pilot:

A/C:

Sequence H



CIVA Advanced 10/29/2023
 Programme4 WAAC 2023

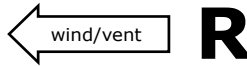

Figure K
344
 Total K
374

Judges Name		Flight #
Signature	Number	

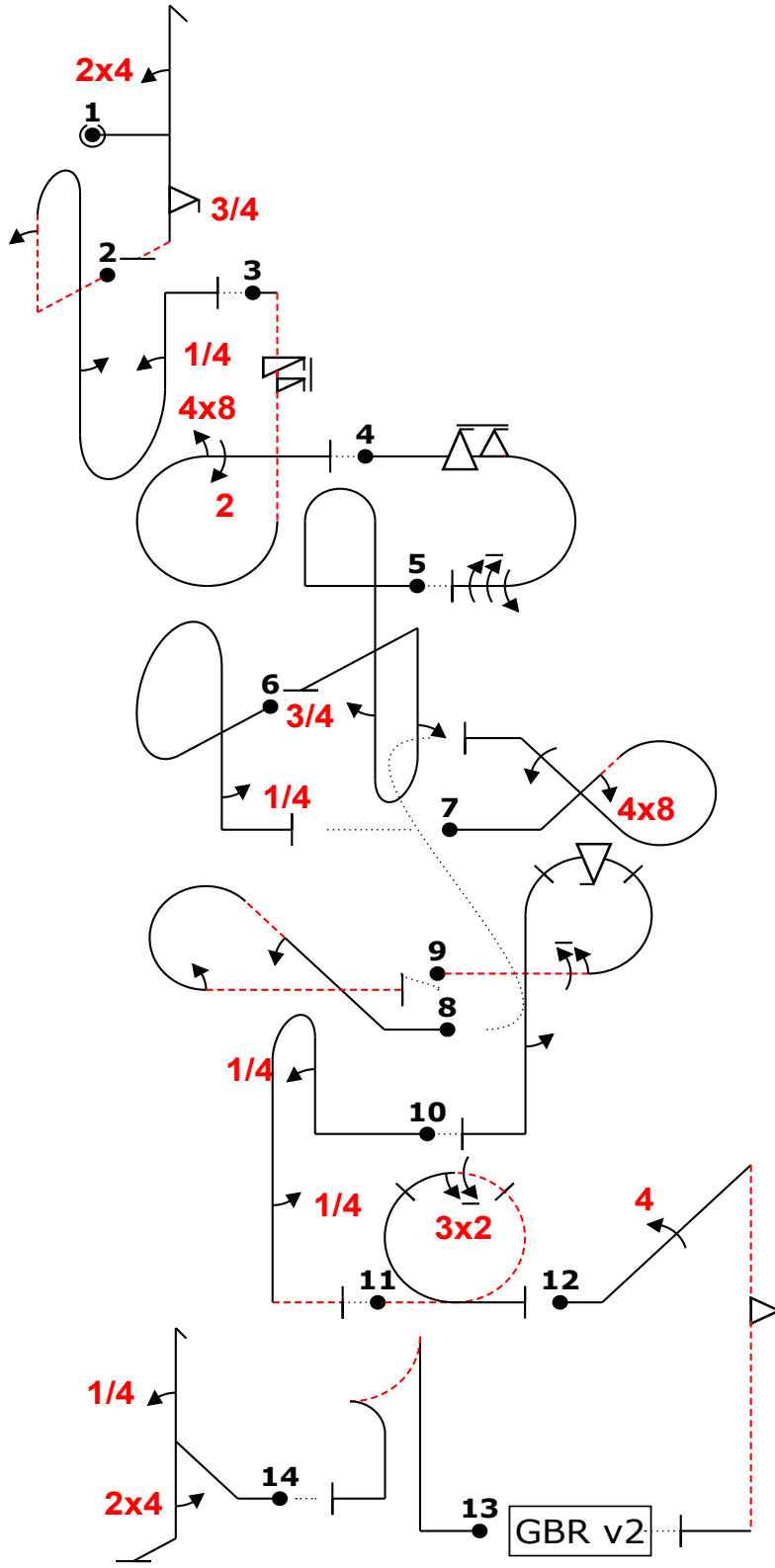

Fig	Grade	Pos	Remarks
1	.		
2	.		
3	.		
4	.		
5	.		
6	.		
7	.		
8	.		
9	.		
10	.		
11	.		
12	.		
13	.		
14	.		

Positioning
30 .

Too Low		Trg Violation	
Too High		Wing Rocks	
Interruptions		Disqual Fig	
Insertions		Other(note...)	

Fig 1 B	K	Fig 2 L	K	Fig 3 I	K	Fig 4 A	K	Fig 5 G	K	Fig 6 L	K	Fig 7 E	K	Fig 8 L	K	Fig 9 D	K	Fig 10 L	K	Fig 11 H	K	Fig 12 C	K	Fig 13 J	K	Fig 14	K
5.2.1.3	18	8.8.7.2	21	8.6.4.3	13	7.2.3.3	6	8.8.2.1	19	8.6.5.1	11	7.3.2.1	14	8.5.4.1	11	8.6.7.2	12	8.4.2.1	14	7.4.2.2	12	1.2.1.1	13	6.2.2.1	15	5.3.1.1	18
9.4.1.2	9	9.1.1.2	8	9.1.1.6	3	9.9.3.6	14	9.1.5.3	6	9.1.5.1	2	9.8.2.2	9	9.1.2.2	6	9.1.3.6	10	9.1.1.1	6	9.2.3.6	12	9.4.2.4	13			9.1.1.1	6
9.9.5.3	11	9.1.5.2	4	9.8.3.2	7	9.1.3.4	8	9.1.1.2	8			9.1.2.4	10	9.1.3.2	4	9.9.3.4	11	9.1.5.1	2			9.9.10.2	13			9.4.5.2	5
		9.1.1.1	6	9.2.3.4	9	9.1.3.8	12									9.1.5.2	4										
	38		6		32		40		33		6		33		6		37		6		24		39		15		29

Pilot:

A/C:

Sequence H



CIVA Advanced 10/29/2023
 Programme4 WAAC 2023

Figure K
344
 Total K
374

Judges Name		Flight #
Signature	Number	

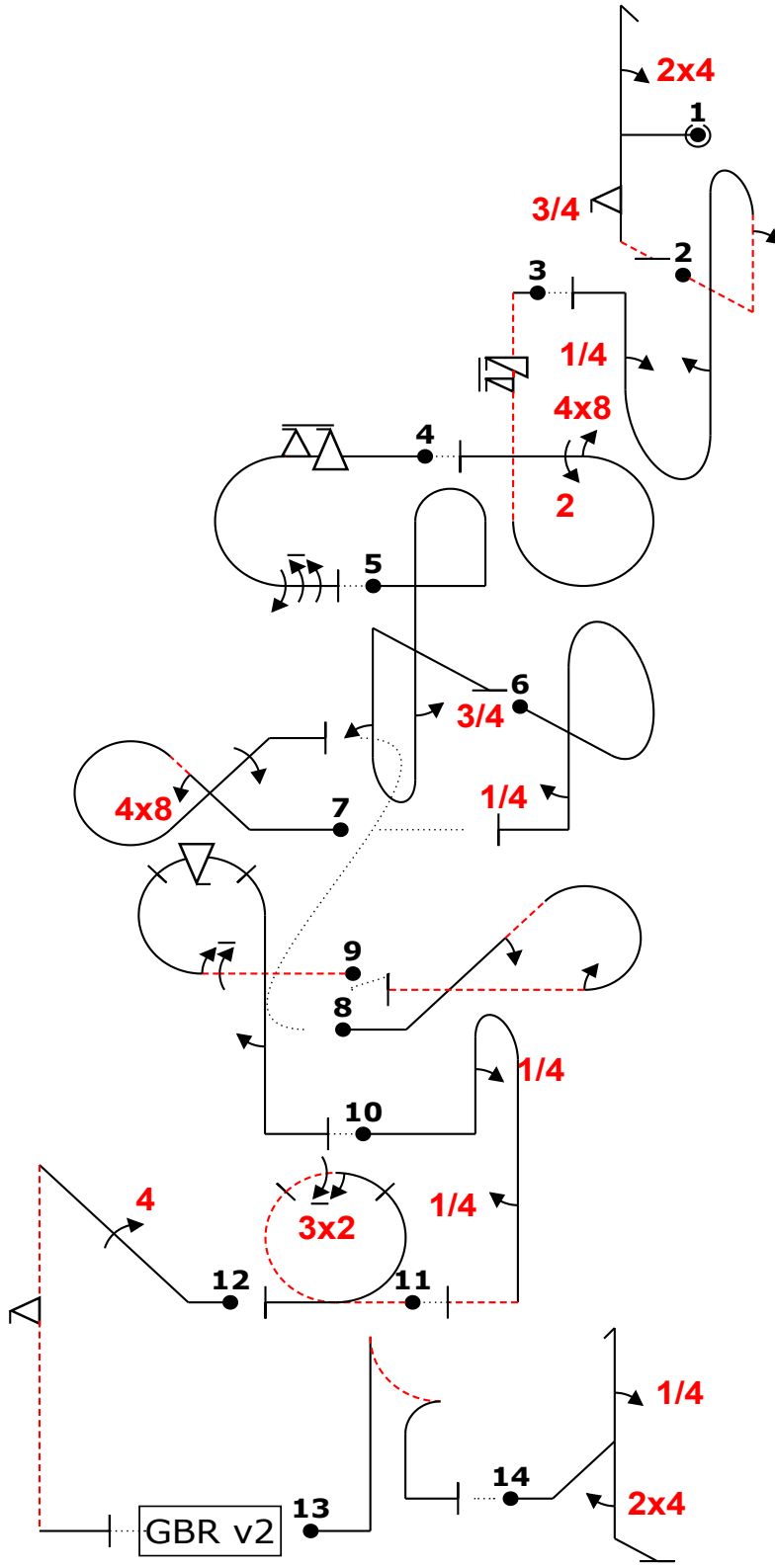
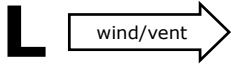

Fig	Grade	Pos	Remarks
1	.		
2	.		
3	.		
4	.		
5	.		
6	.		
7	.		
8	.		
9	.		
10	.		
11	.		
12	.		
13	.		
14	.		

Positioning
30 .

Too Low		Trg Violation	
Too High		Wing Rocks	
Interruptions		Disqual Fig	
Insertions		Other(note...)	

Fig 1 B	K	Fig 2 L	K	Fig 3 I	K	Fig 4 A	K	Fig 5 G	K	Fig 6 L	K	Fig 7 E	K	Fig 8 L	K	Fig 9 D	K	Fig 10 L	K	Fig 11 H	K	Fig 12 C	K	Fig 13 J	K	Fig 14	K
5.2.1.3	18	8.8.7.2	21	8.6.4.3	13	7.2.3.3	6	8.8.2.1	19	8.6.5.1	11	7.3.2.1	14	8.5.4.1	11	8.6.7.2	12	8.4.2.1	14	7.4.2.2	12	1.2.1.1	13	6.2.2.1	15	5.3.1.1	18
9.4.1.2	9	9.1.1.2	8	9.1.1.6	3	9.9.3.6	14	9.1.5.3	6	9.1.5.1	2	9.8.2.2	9	9.1.2.2	6	9.1.3.6	10	9.1.1.1	6	9.2.3.6	12	9.4.2.4	13			9.1.1.1	6
9.9.5.3	11	9.1.5.2	4	9.8.3.2	7	9.1.3.4	8	9.1.1.2	8			9.1.2.4	10	9.1.3.2	4	9.9.3.4	11	9.1.5.1	2			9.9.10.2	13			9.4.5.2	5
		9.1.1.1	6	9.2.3.4	9	9.1.3.8	12									9.1.5.2	4										
	38		6		32		40		33		6		33		6		37		6		24		39		15		29

Pilot:

A/C:

Sequence I



CIVA Advanced 10/29/2023
 Programme4 WAAC 2023

Figure K
344
 Total K
374

Judges Name
 Signature Number

Flight #

wind/vent **R**

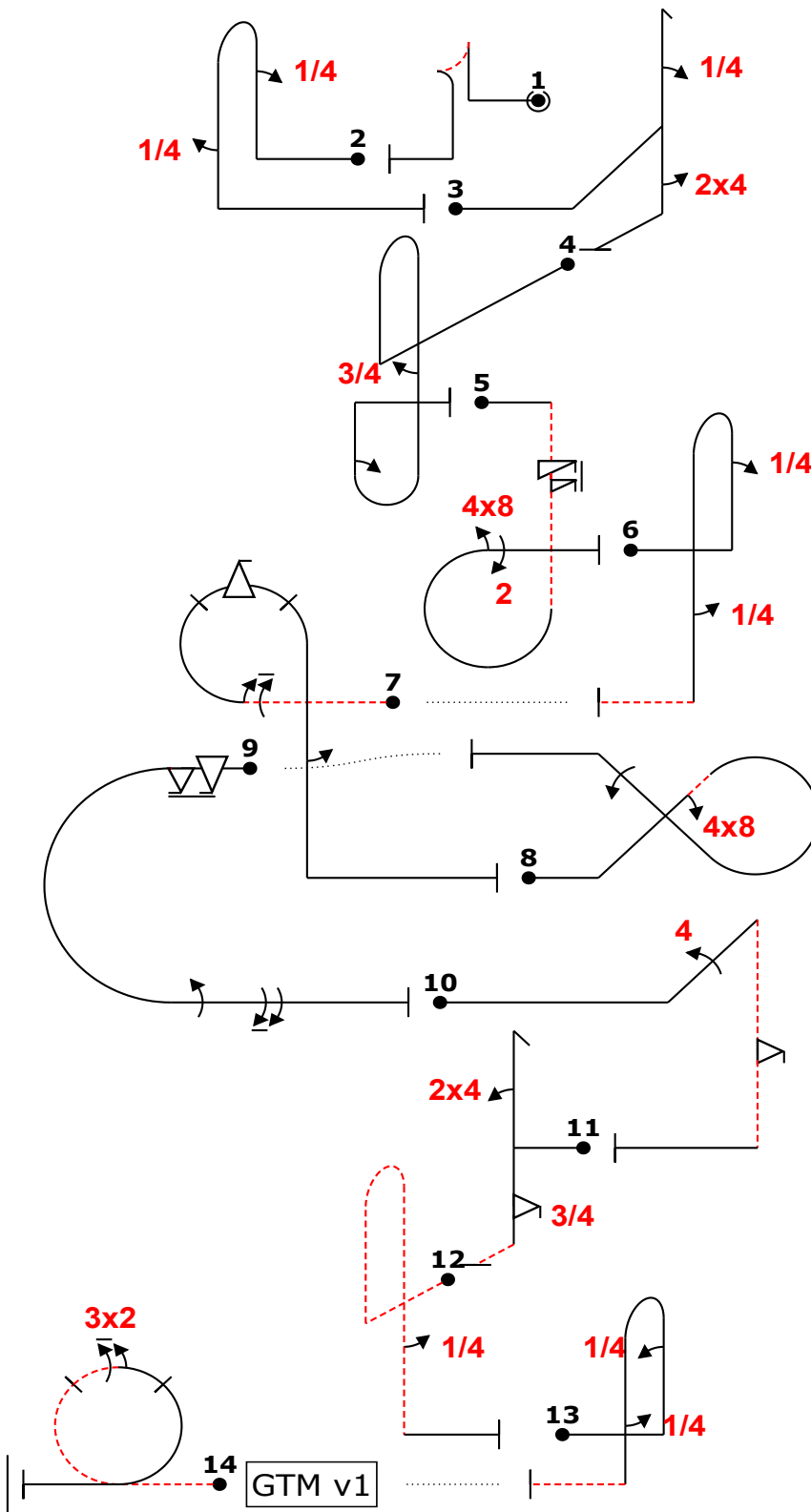

Fig	Grade	Pos	Remarks
1	.		
2	.		
3	.		
4	.		
5	.		
6	.		
7	.		
8	.		
9	.		
10	.		
11	.		
12	.		
13	.		
14	.		

Positioning
30

Too Low		Trg Violation	
Too High		Wing Rocks	
Interruptions		Disqual Fig	
Insertions		Other(note...)	

Fig 1 J	K	Fig 2 L	K	Fig 3 F	K	Fig 4 G	K	Fig 5 I	K	Fig 6 L	K	Fig 7 D	K	Fig 8 E	K	Fig 9 A	K	Fig 10 C	K	Fig 11 B	K	Fig 12 L	K	Fig 13 L	K	Fig 14 H	K
6.2.2.1	15	8.4.1.1	13	5.3.1.1	18	8.8.2.1	19	8.6.4.3	13	8.4.2.1	14	8.6.7.2	12	7.3.2.1	14	7.2.3.3	6	1.2.1.1	13	5.2.1.3	18	8.4.2.2	17	8.4.2.1	14	7.4.2.2	12
		9.1.1.1	6	9.1.1.1	6	9.1.5.3	6	9.1.1.6	3	9.1.1.1	6	9.1.3.6	10	9.8.2.2	9	9.9.3.6	14	9.4.2.4	13	9.4.1.2	9	9.1.5.1	2	9.1.1.1	6	9.2.3.6	12
		9.1.5.1	2	9.4.5.2	5	9.1.1.2	8	9.8.3.2	7	9.1.5.1	2	9.9.3.4	11	9.1.2.4	10	9.1.3.4	8	9.9.10.2	13	9.9.5.3	11			9.1.5.1	2		
	15		6		29		33		32		6		37		33		40		39		38		6		6		24

Pilot:

A/C:

Sequence I



CIVA Advanced 10/29/2023
 Programme4 WAAC 2023

Figure K
344
 Total K
374

Judges Name	Flight #
Signature	Number

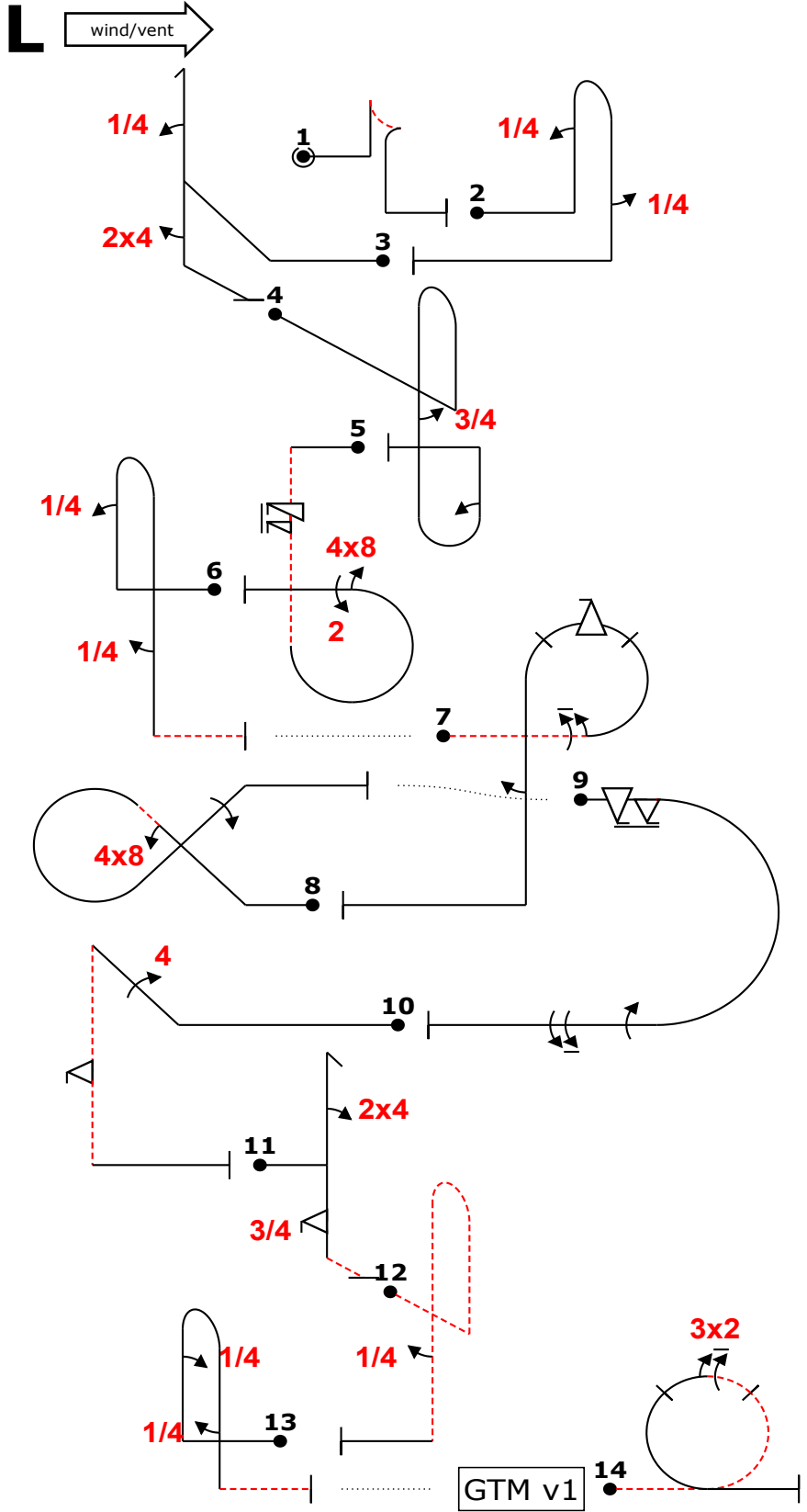

Fig	Grade	Pos	Remarks
1	.		
2	.		
3	.		
4	.		
5	.		
6	.		
7	.		
8	.		
9	.		
10	.		
11	.		
12	.		
13	.		
14	.		

Positioning
30

Too Low		Trg Violation	
Too High		Wing Rocks	
Interruptions		Disqual Fig	
Insertions		Other(note...)	

Fig 1 J	K	Fig 2 L	K	Fig 3 F	K	Fig 4 G	K	Fig 5 I	K	Fig 6 L	K	Fig 7 D	K	Fig 8 E	K	Fig 9 A	K	Fig 10 C	K	Fig 11 B	K	Fig 12 L	K	Fig 13 L	K	Fig 14 H	K
6.2.2.1	15	8.4.1.1	13	5.3.1.1	18	8.8.2.1	19	8.6.4.3	13	8.4.2.1	14	8.6.7.2	12	7.3.2.1	14	7.2.3.3	6	1.2.1.1	13	5.2.1.3	18	8.4.2.2	17	8.4.2.1	14	7.4.2.2	12
		9.1.1.1	6	9.1.1.1	6	9.1.5.3	6	9.1.1.6	3	9.1.1.1	6	9.1.3.6	10	9.8.2.2	9	9.9.3.6	14	9.4.2.4	13	9.4.1.2	9	9.1.5.1	2	9.1.1.1	6	9.2.3.6	12
		9.1.5.1	2	9.4.5.2	5	9.1.1.2	8	9.8.3.2	7	9.1.5.1	2	9.9.3.4	11	9.1.2.4	10	9.1.3.4	8	9.9.10.2	13	9.9.5.3	11			9.1.5.1	2		
	15		6		29		33		32		6		37		33		40		39		38		6		6		24

Pilot:

A/C:

Sequence J



CIVA Advanced

Programme4

Figure K

344

Total K

374

Judges Name

Flight #

Signature

Number

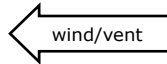

R

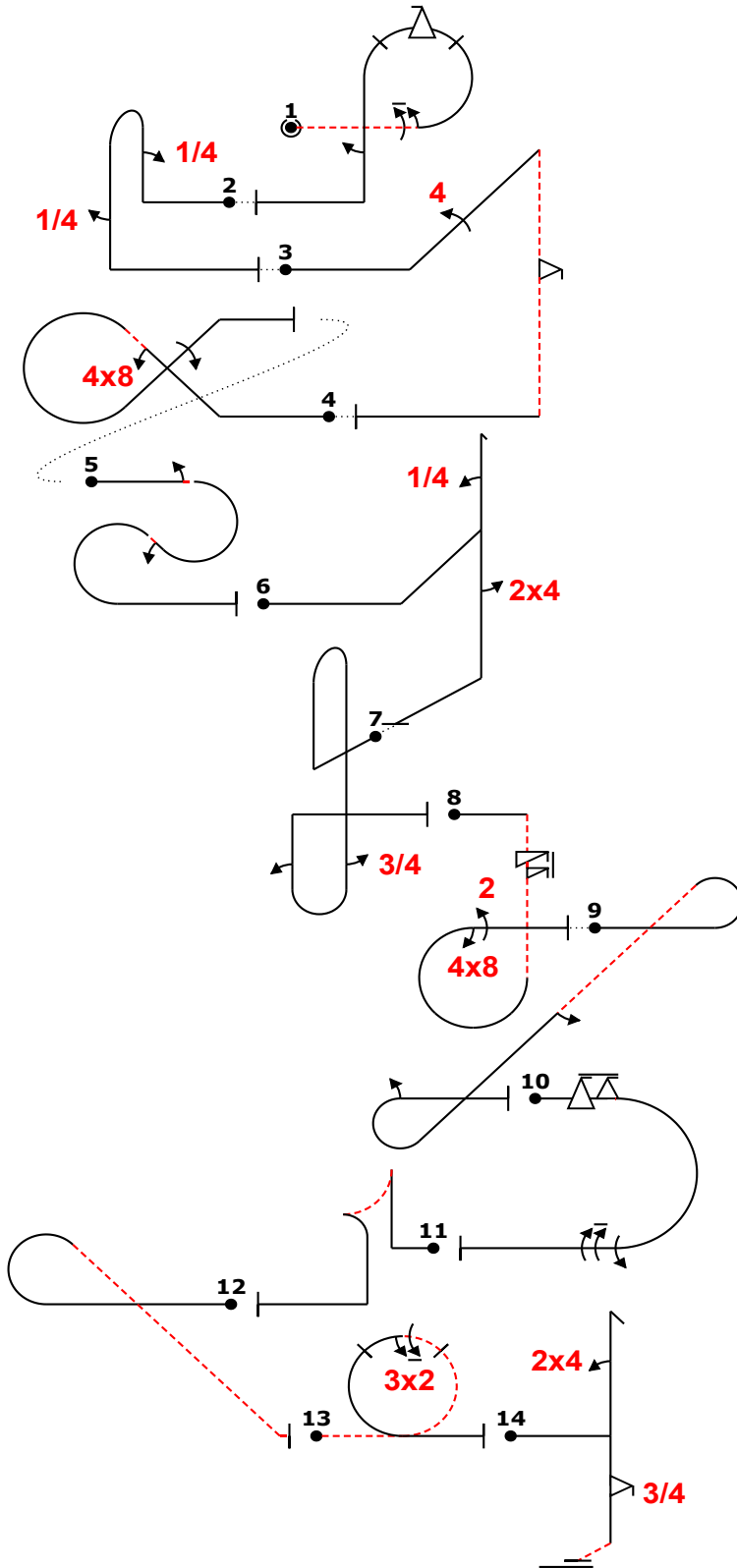

Fig	Grade	Pos	Remarks
1	.		
2	.		
3	.		
4	.		
5	.		
6	.		
7	.		
8	.		
9	.		
10	.		
11	.		
12	.		
13	.		
14	.		

Positioning	
30	.

Too Low		Trg Violation	
Too High		Wing Rocks	
Interruptions		Disqual Fig	
Insertions		Other(note...)	

Fig 1 D	K	Fig 2 L	K	Fig 3 C	K	Fig 4 E	K	Fig 5 L	K	Fig 6 F	K	Fig 7 G	K	Fig 8 I	K	Fig 9 L	K	Fig 10 A	K	Fig 11 J	K	Fig 12 L	K	Fig 13 H	K	Fig 14 B	K
8.6.7.2	12	8.4.1.1	13	1.2.1.1	13	7.3.2.1	14	7.5.5.3	15	5.3.1.1	18	8.8.2.1	19	8.6.4.3	13	7.5.7.1	15	7.2.3.3	6	6.2.2.1	15	8.5.5.1	10	7.4.2.2	12	5.2.1.3	18
9.1.3.6	10	9.1.1.1	6	9.4.2.4	13	9.8.2.2	9	9.1.3.2	4	9.1.1.1	6	9.1.5.3	6	9.1.1.6	3	9.1.4.2	4	9.9.3.6	14					9.2.3.6	12	9.4.1.2	9
9.9.3.4	11	9.1.5.1	2	9.9.10.2	13	9.1.2.4	10	9.1.2.2	6	9.4.5.2	5	9.1.1.2	8	9.8.3.2	7	9.1.3.2	4	9.1.3.4	8							9.9.5.3	11
9.1.5.2	4													9.2.3.4	9			9.1.3.8	12								
	37		6		39		33		6		29		33		32		6		40		15		6		24		38

Pilot:

A/C:

Sequence J



CIVA Advanced

Programme4

Figure K

344

Total K

374

Judges Name

Flight #

Signature

Number

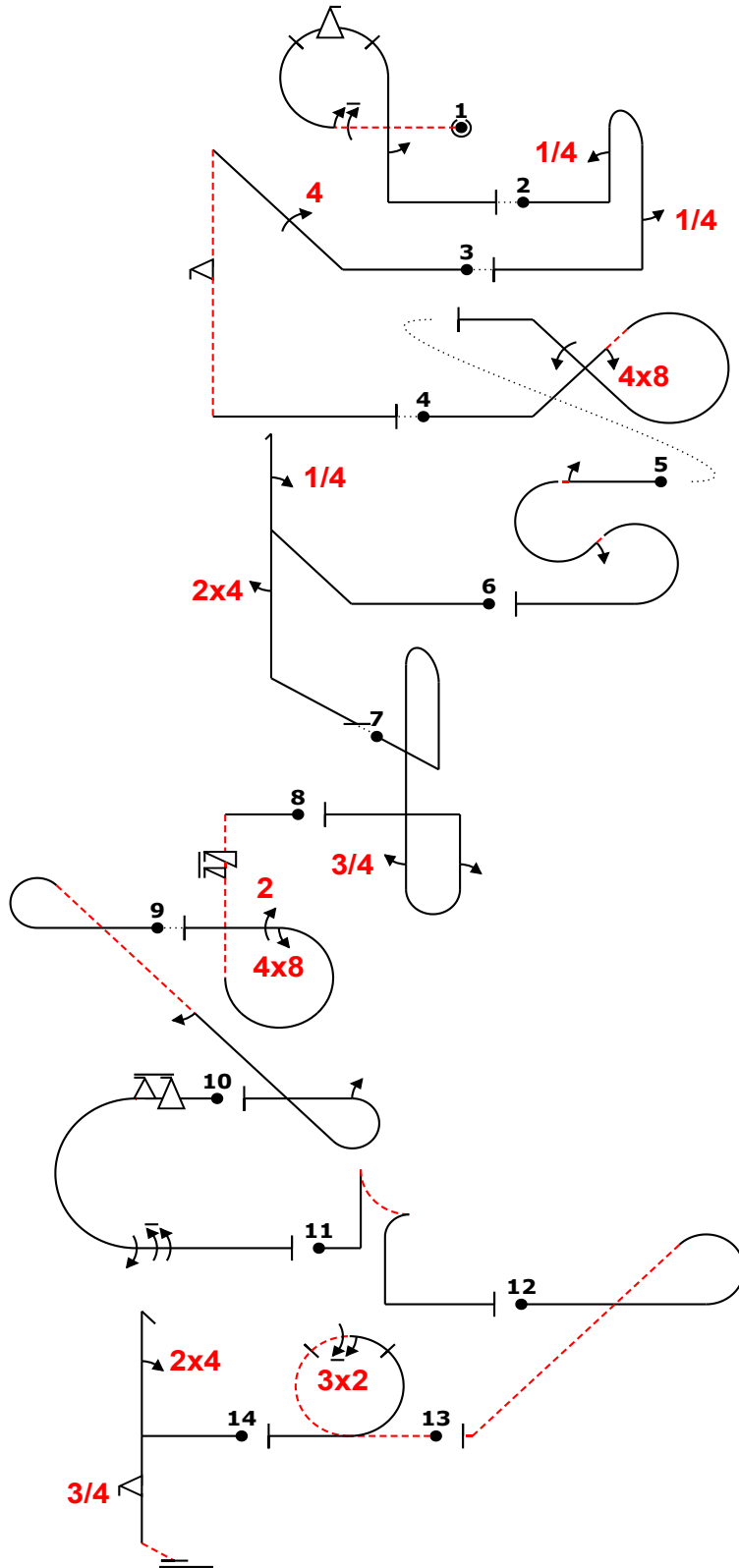
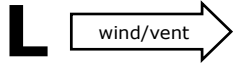

Fig	Grade	Pos	Remarks
1	.		
2	.		
3	.		
4	.		
5	.		
6	.		
7	.		
8	.		
9	.		
10	.		
11	.		
12	.		
13	.		
14	.		

Positioning 30 .

Too Low		Trg Violation	
Too High		Wing Rocks	
Interruptions		Disqual Fig	
Insertions		Other(note...)	

Fig 1 D	K	Fig 2 L	K	Fig 3 C	K	Fig 4 E	K	Fig 5 L	K	Fig 6 F	K	Fig 7 G	K	Fig 8 I	K	Fig 9 L	K	Fig 10 A	K	Fig 11 J	K	Fig 12 L	K	Fig 13 H	K	Fig 14 B	K
8.6.7.2	12	8.4.1.1	13	1.2.1.1	13	7.3.2.1	14	7.5.5.3	15	5.3.1.1	18	8.8.2.1	19	8.6.4.3	13	7.5.7.1	15	7.2.3.3	6	6.2.2.1	15	8.5.5.1	10	7.4.2.2	12	5.2.1.3	18
9.1.3.6	10	9.1.1.1	6	9.4.2.4	13	9.8.2.2	9	9.1.3.2	4	9.1.1.1	6	9.1.5.3	6	9.1.1.6	3	9.1.4.2	4	9.9.3.6	14					9.2.3.6	12	9.4.1.2	9
9.9.3.4	11	9.1.5.1	2	9.9.10.2	13	9.1.2.4	10	9.1.2.2	6	9.4.5.2	5	9.1.1.2	8	9.8.3.2	7	9.1.3.2	4	9.1.3.4	8							9.9.5.3	11
9.1.5.2	4													9.2.3.4	9			9.1.3.8	12								
	37		6		39		33		6		29		33		32		6		40		15		6		24		38

Pilot:

A/C:

Sequence K



CIVA Advanced

Programme4

Figure K

344

Total K

374

Judges Name		Flight #
Signature	Number	

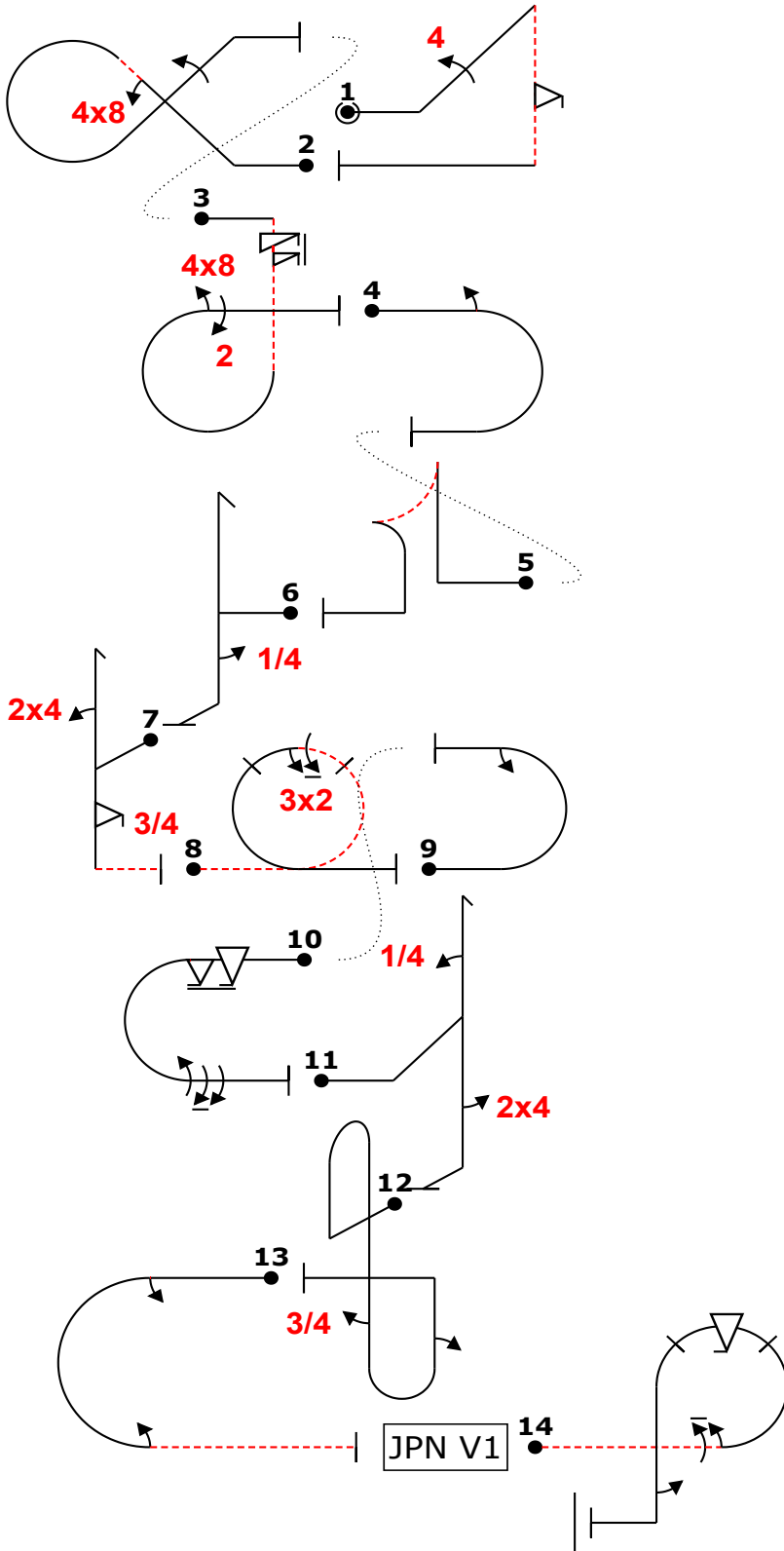
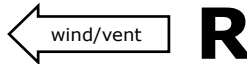

Fig	Grade	Pos	Remarks
1	.		
2	.		
3	.		
4	.		
5	.		
6	.		
7	.		
8	.		
9	.		
10	.		
11	.		
12	.		
13	.		
14	.		

Positioning	30	.
-------------	----	---

Too Low		Trg Violation	
Too High		Wing Rocks	
Interruptions		Disqual Fig	
Insertions		Other(note...)	

Fig 1 C	K	Fig 2 E	K	Fig 3 I	K	Fig 4 L	K	Fig 5 J	K	Fig 6 L	K	Fig 7 B	K	Fig 8 H	K	Fig 9 L	K	Fig 10 A	K	Fig 11 F	K	Fig 12 G	K	Fig 13 L	K	Fig 14 D	K
1.2.1.1	13	7.3.2.1	14	8.6.4.3	13	7.2.3.3	6	6.2.2.1	15	5.2.1.1	17	5.2.1.3	18	7.4.2.2	12	7.2.2.1	6	7.2.3.3	6	5.3.1.1	18	8.8.2.1	19	7.2.4.3	6	8.6.7.2	12
9.4.2.4	13	9.8.2.2	9	9.1.1.6	3	9.1.3.2	4			9.1.5.1	2	9.4.1.2	9	9.2.3.6	12	9.1.3.2	4	9.9.3.6	14	9.1.1.1	6	9.1.5.3	6	9.1.3.2	4	9.1.3.6	10
9.9.10.2	13	9.1.2.4	10	9.8.3.2	7	9.2.3.4	9					9.9.5.3	11					9.1.3.4	8	9.4.5.2	5	9.1.1.2	8	9.1.3.2	4	9.9.3.4	11
																		9.1.3.8	12							9.1.5.2	4
	39		33		32		6		15		6		38		24		6		40		29		33		6		37

Pilot:

A/C:

Sequence K



CIVA Advanced

Programme4

Figure K

344

Total K

374

Judges Name	
Signature	Number

Flight #

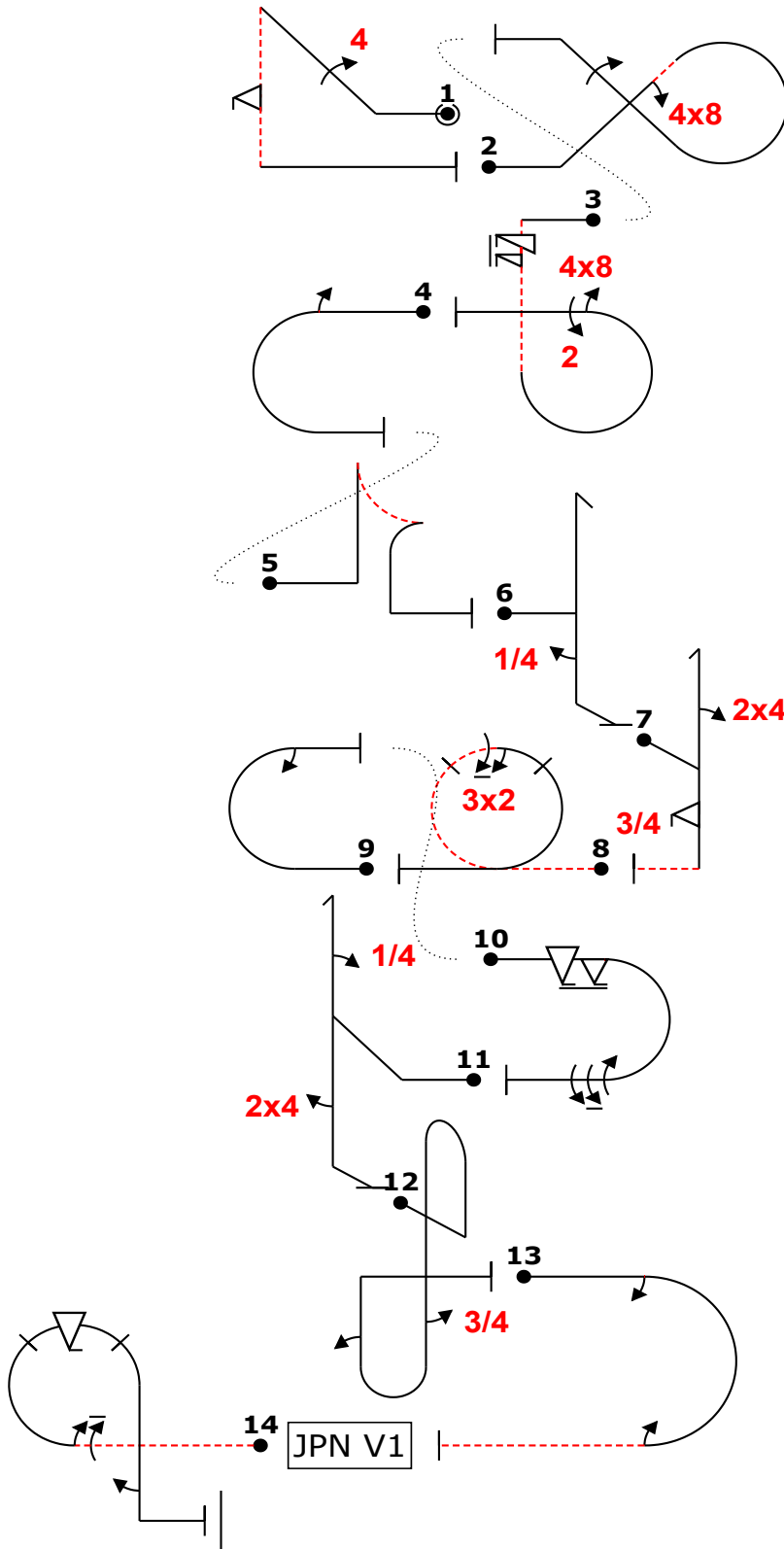
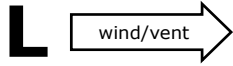

Fig	Grade	Pos	Remarks
1	.		
2	.		
3	.		
4	.		
5	.		
6	.		
7	.		
8	.		
9	.		
10	.		
11	.		
12	.		
13	.		
14	.		

Positioning	30	.
-------------	----	---

Too Low		Trg Violation	
Too High		Wing Rocks	
Interruptions		Disqual Fig	
Insertions		Other(note...)	

Fig	K	Fig	K	Fig	K	Fig	K	Fig	K	Fig	K	Fig	K	Fig	K	Fig	K
1.2.1.1	13	7.3.2.1	14	8.6.4.3	13	7.2.3.3	6	6.2.2.1	15	5.2.1.1	17	5.2.1.3	18	7.4.2.2	12	7.2.2.1	6
9.4.2.4	13	9.8.2.2	9	9.11.1.6	3	9.1.3.2	4			9.1.5.1	2	9.4.1.2	9	9.2.3.6	12	9.1.3.2	4
9.9.10.2	13	9.1.2.4	10	9.8.3.2	7							9.9.5.3	11				
				9.2.3.4	9											9.1.3.8	12
	39		33		32		6		15		6		38		24		6
																	40
																	29
																	33
																	6
																	37

Pilot:

A/C:

Sequence L



CIVA Advanced 10/29/2023
 Programme4 WAAC 2023

Figure K
344
 Total K
374

Judges Name		Flight #
Signature	Number	

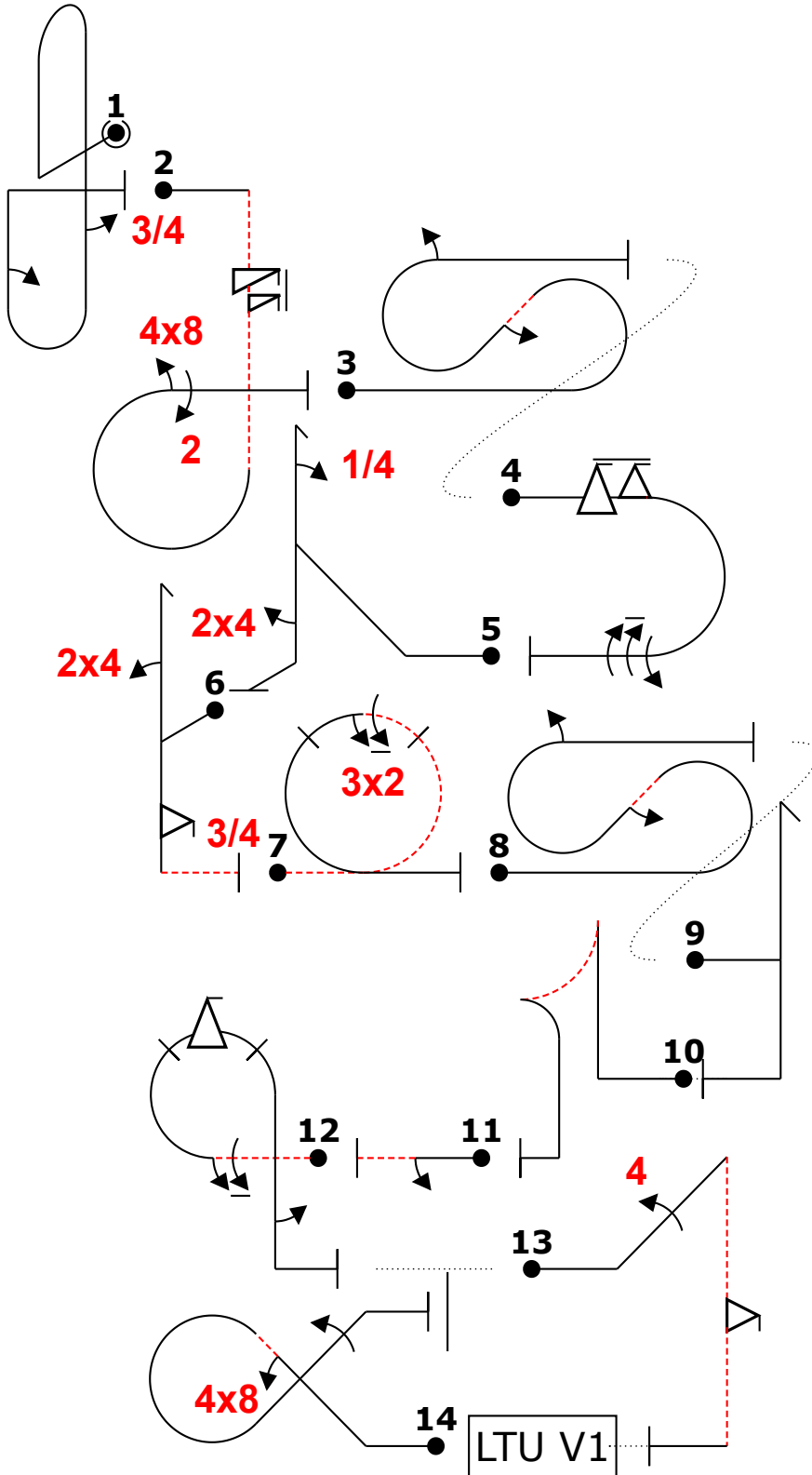
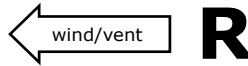

Fig	Grade	Pos	Remarks
1	.		
2	.		
3	.		
4	.		
5	.		
6	.		
7	.		
8	.		
9	.		
10	.		
11	.		
12	.		
13	.		
14	.		

Positioning
30 .

Too Low		Trg Violation	
Too High		Wing Rocks	
Interruptions		Disqual Fig	
Insertions		Other(note...)	

Fig 1 G	K	Fig 2 I	K	Fig 3 L	K	Fig 4 A	K	Fig 5 F	K	Fig 6 B	K	Fig 7 H	K	Fig 8 L	K	Fig 9 L	K	Fig 10 J	K	Fig 11 L	K	Fig 12 D	K	Fig 13 C	K	Fig 14 E	K
8.8.2.1	19	8.6.4.3	13	7.5.7.1	15	7.2.3.3	6	5.3.1.1	18	5.2.1.3	18	7.4.2.2	12	7.5.7.1	15	5.2.1.1	17	6.2.2.1	15	1.1.1.3	2	8.6.7.2	12	1.2.1.1	13	7.3.2.1	14
9.1.5.3	6	9.11.1.6	3	9.1.4.2	4	9.9.3.6	14	9.1.1.1	6	9.4.1.2	9	9.2.3.6	12	9.1.4.2	4					9.1.3.2	4	9.1.3.6	10	9.4.2.4	13	9.8.2.2	9
9.1.1.2	8	9.8.3.2	7	9.1.3.2	4	9.1.3.4	8	9.4.5.2	5	9.9.5.3	11			9.1.3.2	4							9.9.3.4	11	9.9.10.2	13	9.1.2.4	10
		9.2.3.4	9	9.1.3.8	12																	9.1.5.2	4				
	33		32		6		40		29		38		24		6		6		15		6		37		39		33

Pilot:

A/C:

Sequence L



CIVA Advanced 10/29/2023
 Programme4 WAAC 2023

Figure K
344
 Total K
374

Judges Name	
Signature	Number

Flight #

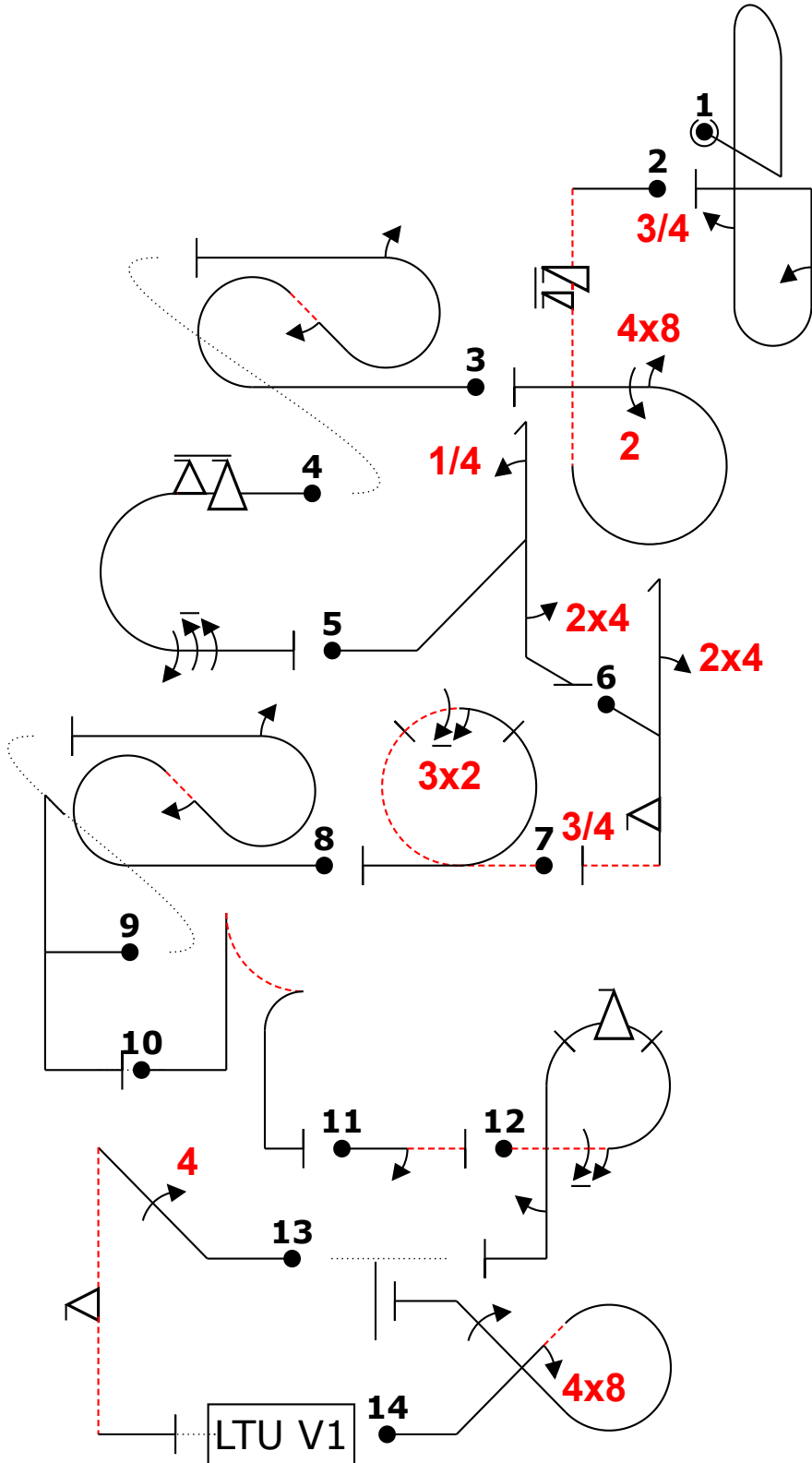
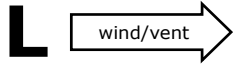

Fig	Grade	Pos	Remarks
1	.		
2	.		
3	.		
4	.		
5	.		
6	.		
7	.		
8	.		
9	.		
10	.		
11	.		
12	.		
13	.		
14	.		

Positioning	
30	.

Too Low		Trg Violation	
Too High		Wing Rocks	
Interruptions		Disqual Fig	
Insertions		Other(note...)	

Fig 1 G	K	Fig 2 I	K	Fig 3 L	K	Fig 4 A	K	Fig 5 F	K	Fig 6 B	K	Fig 7 H	K	Fig 8 L	K	Fig 9 L	K	Fig 10 J	K	Fig 11 L	K	Fig 12 D	K	Fig 13 C	K	Fig 14 E	K
8.8.2.1	19	8.6.4.3	13	7.5.7.1	15	7.2.3.3	6	5.3.1.1	18	5.2.1.3	18	7.4.2.2	12	7.5.7.1	15	5.2.1.1	17	6.2.2.1	15	1.1.1.3	2	8.6.7.2	12	1.2.1.1	13	7.3.2.1	14
9.1.5.3	6	9.1.1.6	3	9.1.4.2	4	9.9.3.6	14	9.1.1.1	6	9.4.1.2	9	9.2.3.6	12	9.1.4.2	4					9.1.3.2	4	9.1.3.6	10	9.4.2.4	13	9.8.2.2	9
9.1.1.2	8	9.8.3.2	7	9.1.3.2	4	9.1.3.4	8	9.4.5.2	5	9.9.5.3	11			9.1.3.2	4							9.9.3.4	11	9.9.10.2	13	9.1.2.4	10
		9.2.3.4	9			9.1.3.8	12															9.1.5.2	4				
	33		32		6		40		29		38		24		6		6		15		6		37		39		33

Pilot:

A/C:

Sequence M



CIVA Advanced 10/29/2023
 Programme4 WAAC 2023

Figure K
344
 Total K
374

Judges Name		Flight #
Signature	Number	

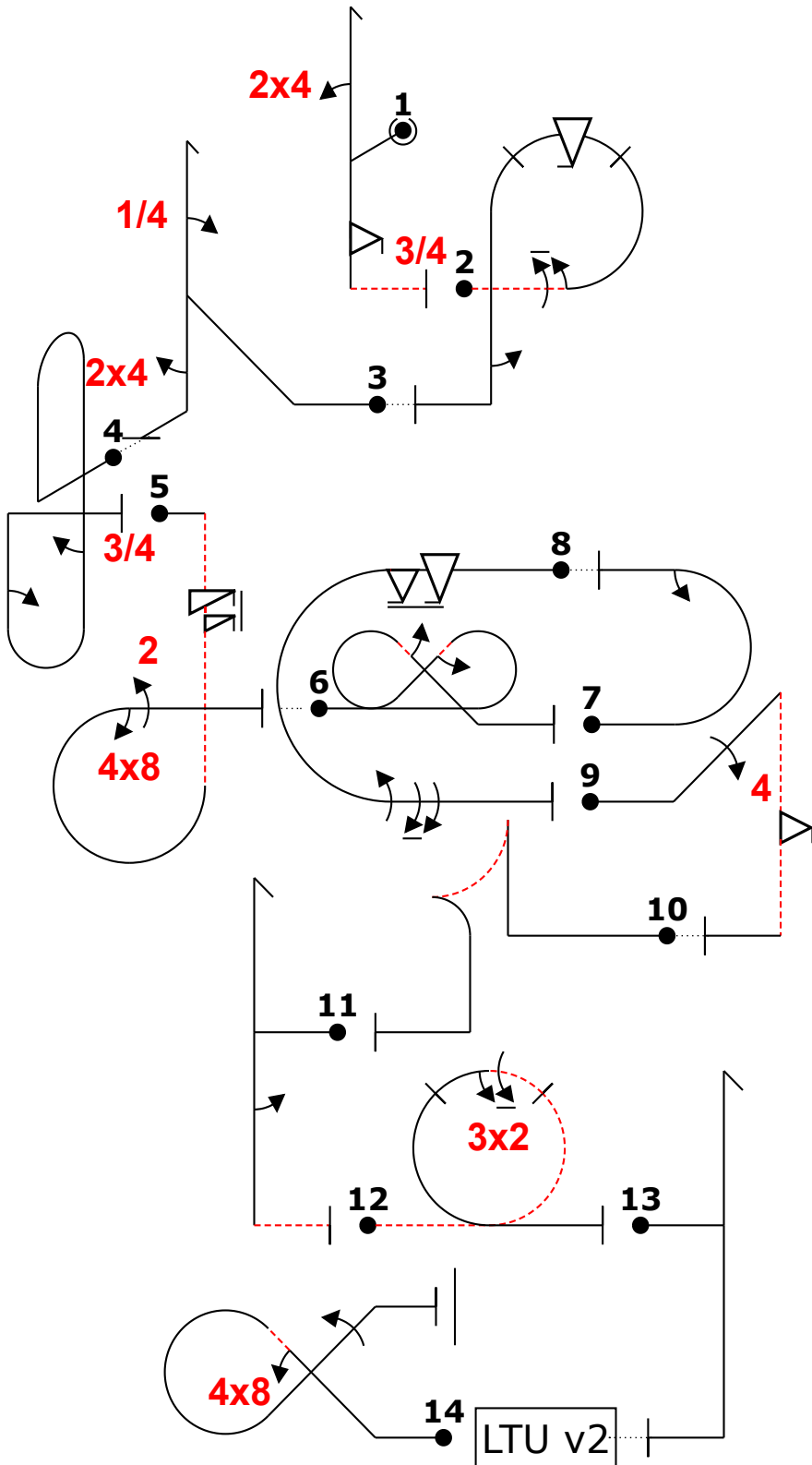
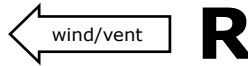

Fig	Grade	Pos	Remarks
1	.		
2	.		
3	.		
4	.		
5	.		
6	.		
7	.		
8	.		
9	.		
10	.		
11	.		
12	.		
13	.		
14	.		

Positioning
30 .

Too Low		Trg Violation	
Too High		Wing Rocks	
Interruptions		Disqual Fig	
Insertions		Other(note...)	

Fig 1 B	K	Fig 2 D	K	Fig 3 F	K	Fig 4 G	K	Fig 5 I	K	Fig 6 L	K	Fig 7 L	K	Fig 8 A	K	Fig 9 C	K	Fig 10 J	K	Fig 11 L	K	Fig 12 H	K	Fig 13 L	K	Fig 14 E	K
5.2.1.3	18	8.6.7.2	12	5.3.1.1	18	8.8.2.1	19	8.6.4.3	13	7.8.4.1	19	7.2.2.1	6	7.2.3.3	6	1.2.1.1	13	6.2.2.1	15	5.2.1.3	18	7.4.2.2	12	5.2.1.1	17	7.3.2.1	14
9.4.1.2	9	9.1.3.6	10	9.1.1.1	6	9.1.5.3	6	9.1.1.6	3	9.1.4.2	4	9.1.3.2	4	9.9.3.6	14	9.4.2.4	13			9.1.5.2	4	9.2.3.6	12			9.8.2.2	9
9.9.5.3	11	9.9.3.4	11	9.4.5.2	5	9.1.1.2	8	9.8.3.2	7	9.1.4.2	4			9.1.3.4	8	9.9.10.2	13									9.1.2.4	10
		9.1.5.2	4					9.2.3.4	9					9.1.3.8	12												
	38		37		29		33		32		6		6		40		39		15		6		24		6		33

Pilot:

A/C:

Sequence M



CIVA Advanced 10/29/2023
 Programme4 WAAC 2023

Figure K
344
 Total K
374

Judges Name		Flight #
Signature	Number	

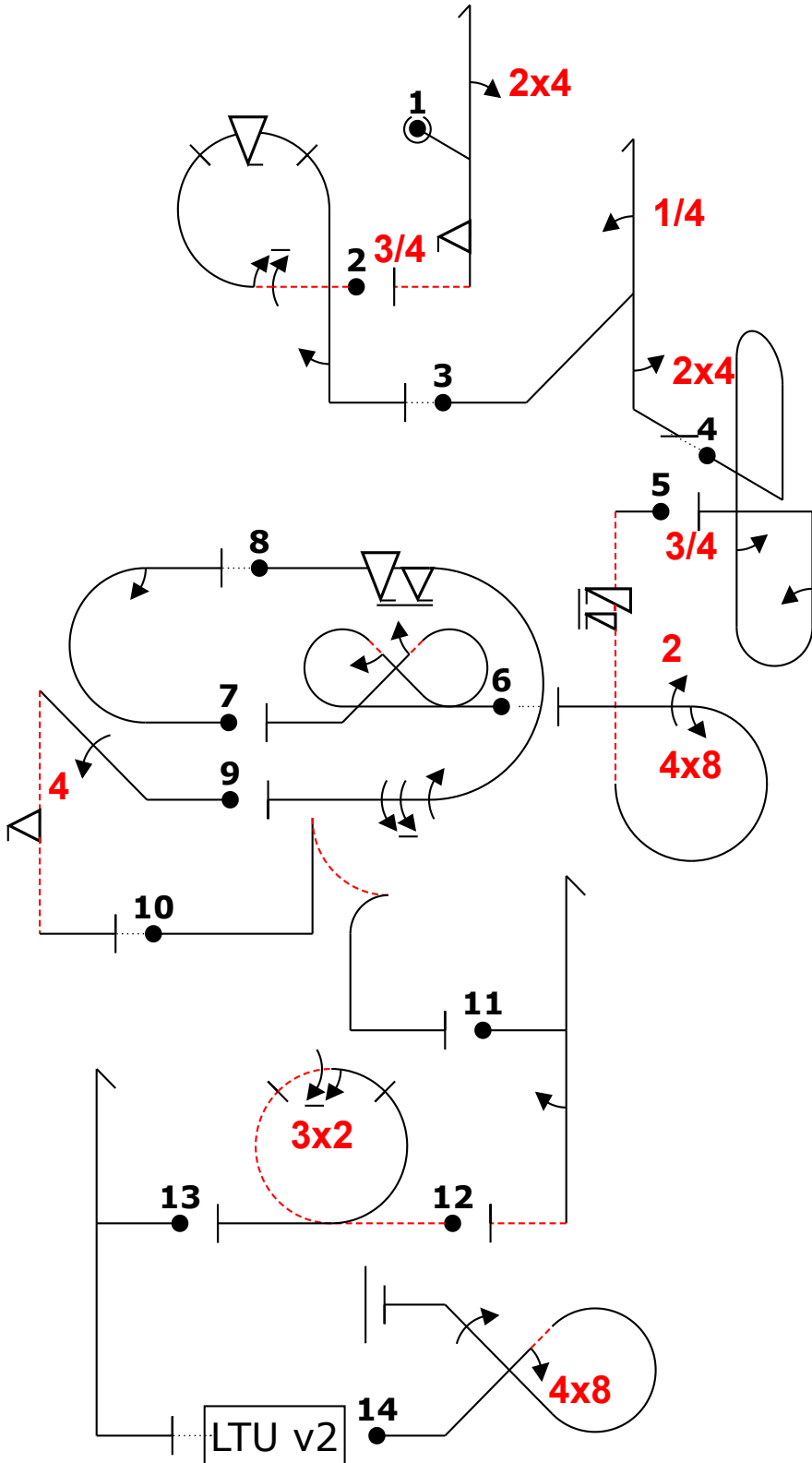
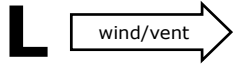

Fig	Grade	Pos	Remarks
1	.		
2	.		
3	.		
4	.		
5	.		
6	.		
7	.		
8	.		
9	.		
10	.		
11	.		
12	.		
13	.		
14	.		

Positioning
30

Too Low	<input type="checkbox"/>	Trg Violation	<input type="checkbox"/>
Too High	<input type="checkbox"/>	Wing Rocks	<input type="checkbox"/>
Interruptions	<input type="checkbox"/>	Disqual Fig	<input type="checkbox"/>
Insertions	<input type="checkbox"/>	Other(note...)	<input type="checkbox"/>

Fig 1 B	K	Fig 2 D	K	Fig 3 F	K	Fig 4 G	K	Fig 5 I	K	Fig 6 L	K	Fig 7 L	K	Fig 8 A	K	Fig 9 C	K	Fig 10 J	K	Fig 11 L	K	Fig 12 H	K	Fig 13 L	K	Fig 14 E	K
5.2.1.3	18	8.6.7.2	12	5.3.1.1	18	8.8.2.1	19	8.6.4.3	13	7.8.4.1	19	7.2.2.1	6	7.2.3.3	6	1.2.1.1	13	6.2.2.1	15	5.2.1.3	18	7.4.2.2	12	5.2.1.1	17	7.3.2.1	14
9.4.1.2	9	9.1.3.6	10	9.1.1.1	6	9.1.5.3	6	9.1.1.6	3	9.1.4.2	4	9.1.3.2	4	9.9.3.6	14	9.4.2.4	13			9.1.5.2	4	9.2.3.6	12			9.8.2.2	9
9.9.5.3	11	9.9.3.4	11	9.4.5.2	5	9.1.1.2	8	9.8.3.2	7	9.1.4.2	4			9.1.3.4	8	9.9.10.2	13			9.1.5.2	4					9.1.2.4	10
		9.1.5.2	4					9.2.3.4	9					9.1.3.8	12												
	38		37		29		33		32		6		6		40		39		15		6		24		6		33

Pilot:

A/C:

Sequence N



CIVA Advanced 10/29/2023
 Programme4 WAAC 2023



Figure K
344
 Total K
374

Judges Name		Flight #
Signature	Number	

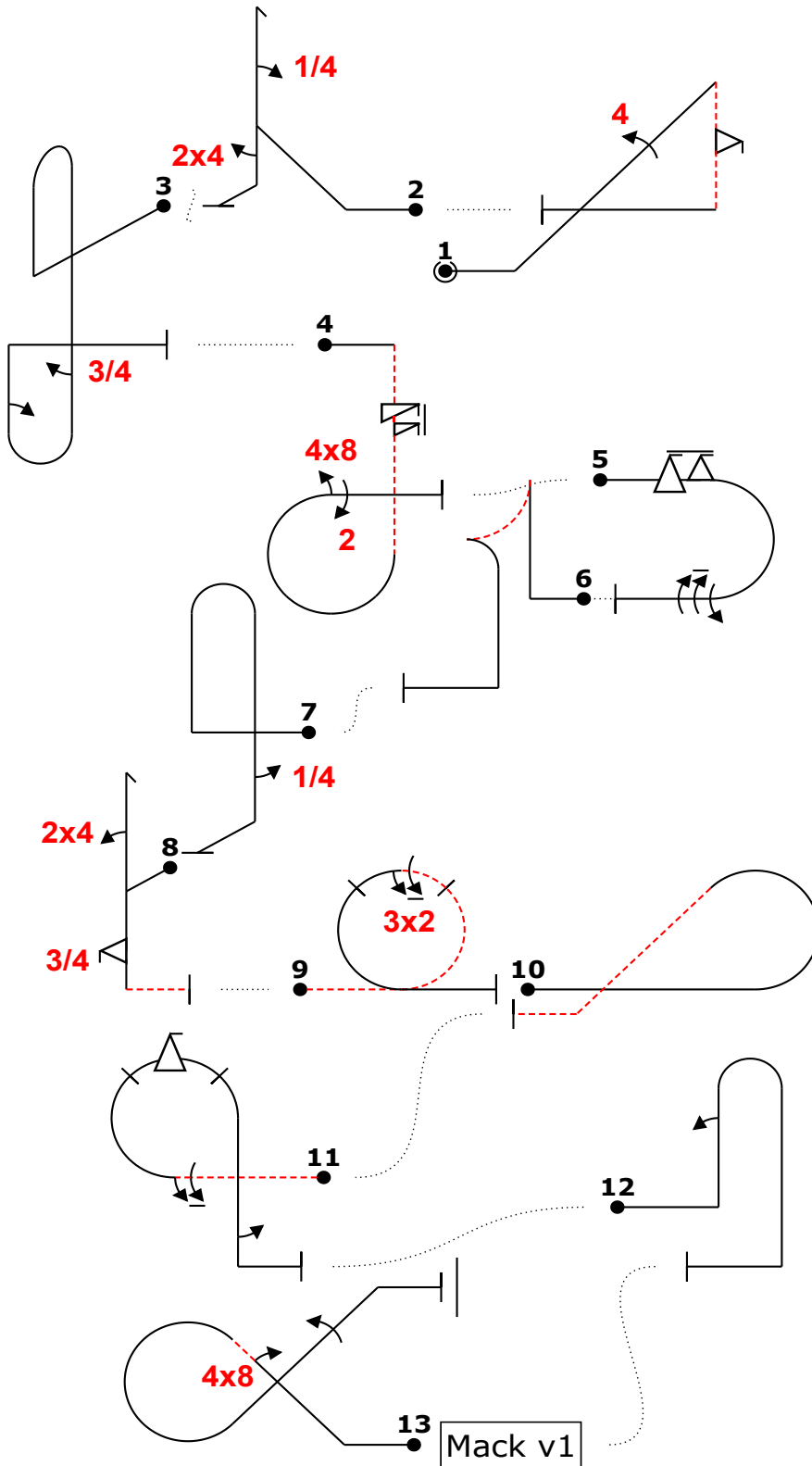

Fig	Grade	Pos	Remarks
1	.		
2	.		
3	.		
4	.		
5	.		
6	.		
7	.		
8	.		
9	.		
10	.		
11	.		
12	.		
13	.		

Positioning	
30	.

Too Low		Trg Violation	
Too High		Wing Rocks	
Interruptions		Disqual Fig	
Insertions		Other(note...)	

Fig 1 C	K	Fig 2 F	K	Fig 3 G	K	Fig 4 I	K	Fig 5 A	K	Fig 6 J	K	Fig 7 L	K	Fig 8 B	K	Fig 9 H	K	Fig 10 L	K	Fig 11 D	K	Fig 12 L	K	Fig 13 E	K
1.2.1.1	13	5.3.1.1	18	8.8.2.1	19	8.6.4.3	13	7.2.3.3	6	6.2.2.1	15	8.4.1.1	13	5.2.1.3	18	7.4.2.2	12	8.5.5.1	10	8.6.7.2	12	8.4.1.1	13	7.3.2.1	14
9.4.2.4	13	9.1.1.1	6	9.1.5.3	6	9.1.1.6	3	9.9.3.6	14			9.1.5.1	2	9.4.1.2	9	9.2.3.6	12			9.1.3.6	10	9.1.1.2	8	9.8.2.2	9
9.9.10.2	13	9.4.5.2	5	9.1.1.2	8	9.8.3.2	7	9.1.3.4	8					9.9.5.3	11					9.9.3.4	11			9.1.2.4	10
						9.2.3.4	9	9.1.3.8	12											9.1.5.2	4				
	39		29		33		32		40		15		8		38		24		8		37		8		33

Pilot: Mark

A/C: 330SC

Team: CAN

Sequence N



CIVA Advanced 10/29/2023
 Programme4 WAAC 2023

Figure K
344
 Total K
374

Judges Name		Flight #
Signature	Number	

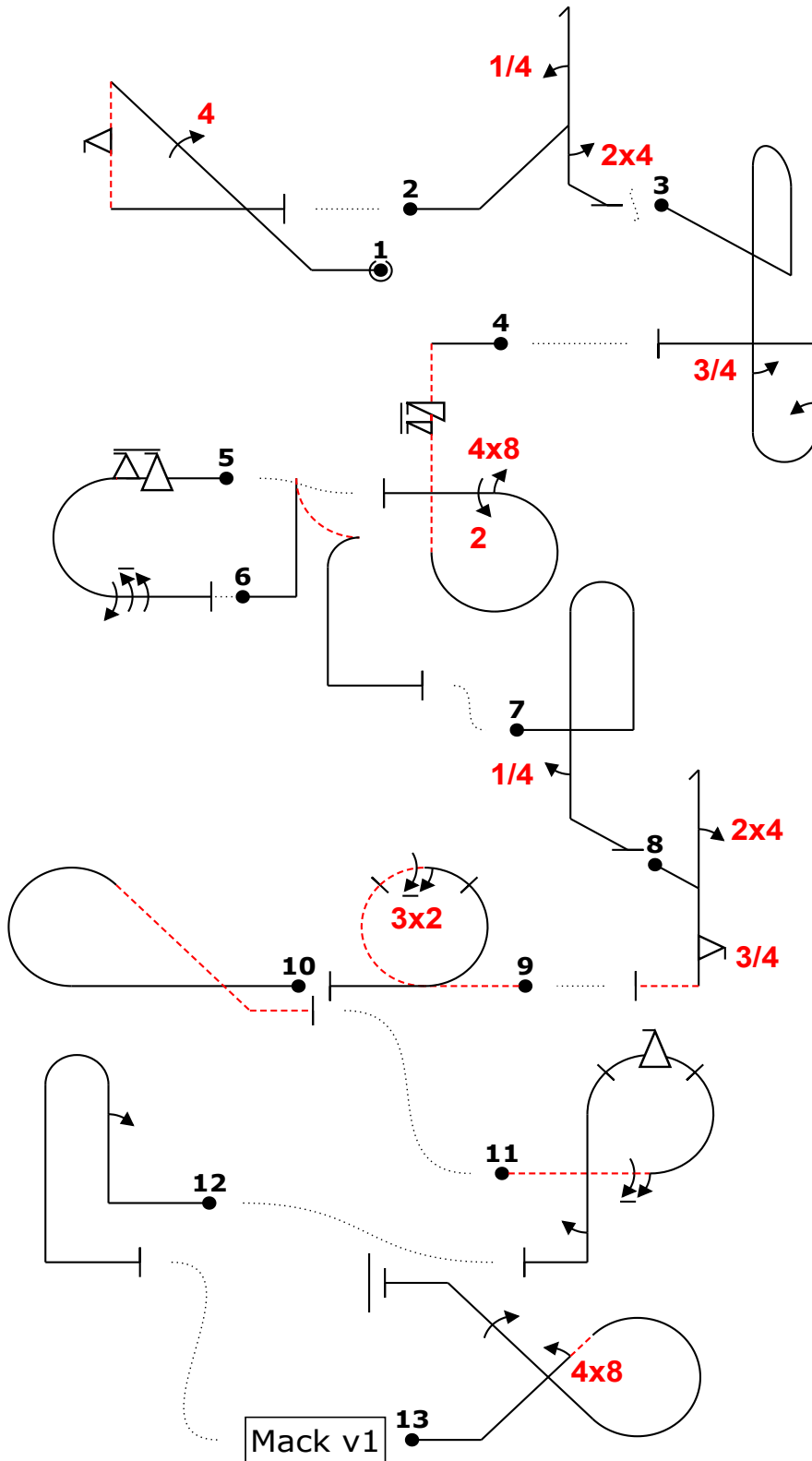
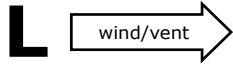

Mack v1

Fig	Grade	Pos	Remarks
1	.		
2	.		
3	.		
4	.		
5	.		
6	.		
7	.		
8	.		
9	.		
10	.		
11	.		
12	.		
13	.		

Positioning
30

Too Low	<input type="checkbox"/>	Trg Violation	<input type="checkbox"/>
Too High	<input type="checkbox"/>	Wing Rocks	<input type="checkbox"/>
Interruptions	<input type="checkbox"/>	Disqual Fig	<input type="checkbox"/>
Insertions	<input type="checkbox"/>	Other(note...)	<input type="checkbox"/>

Fig 1 C	K	Fig 2 F	K	Fig 3 G	K	Fig 4 I	K	Fig 5 A	K	Fig 6 J	K	Fig 7 L	K	Fig 8 B	K	Fig 9 H	K	Fig 10 L	K	Fig 11 D	K	Fig 12 L	K	Fig 13 E	K
1.2.1.1	13	5.3.1.1	18	8.8.2.1	19	8.6.4.3	13	7.2.3.3	6	6.2.2.1	15	8.4.1.1	13	5.2.1.3	18	7.4.2.2	12	8.5.5.1	10	8.6.7.2	12	8.4.1.1	13	7.3.2.1	14
9.4.2.4	13	9.1.1.1	6	9.1.5.3	6	9.1.1.6	3	9.9.3.6	14			9.1.5.1	2	9.4.1.2	9	9.2.3.6	12			9.1.3.6	10	9.1.1.2	8	9.8.2.2	9
9.9.10.2	13	9.4.5.2	5	9.1.1.2	8	9.8.3.2	7	9.1.3.4	8			9.1.3.8	12	9.9.5.3	11					9.9.3.4	11			9.1.2.4	10
	39		29		33		32		40		15		8		38		24		8		37		8		33

Pilot: Mark

A/C: 330SC

Team: CAN

Sequence O



CIVA Advanced 10/29/2023
 Programme4 WAAC 2023

Figure K
344
 Total K
374

Judges Name	
Signature	Number

Flight #

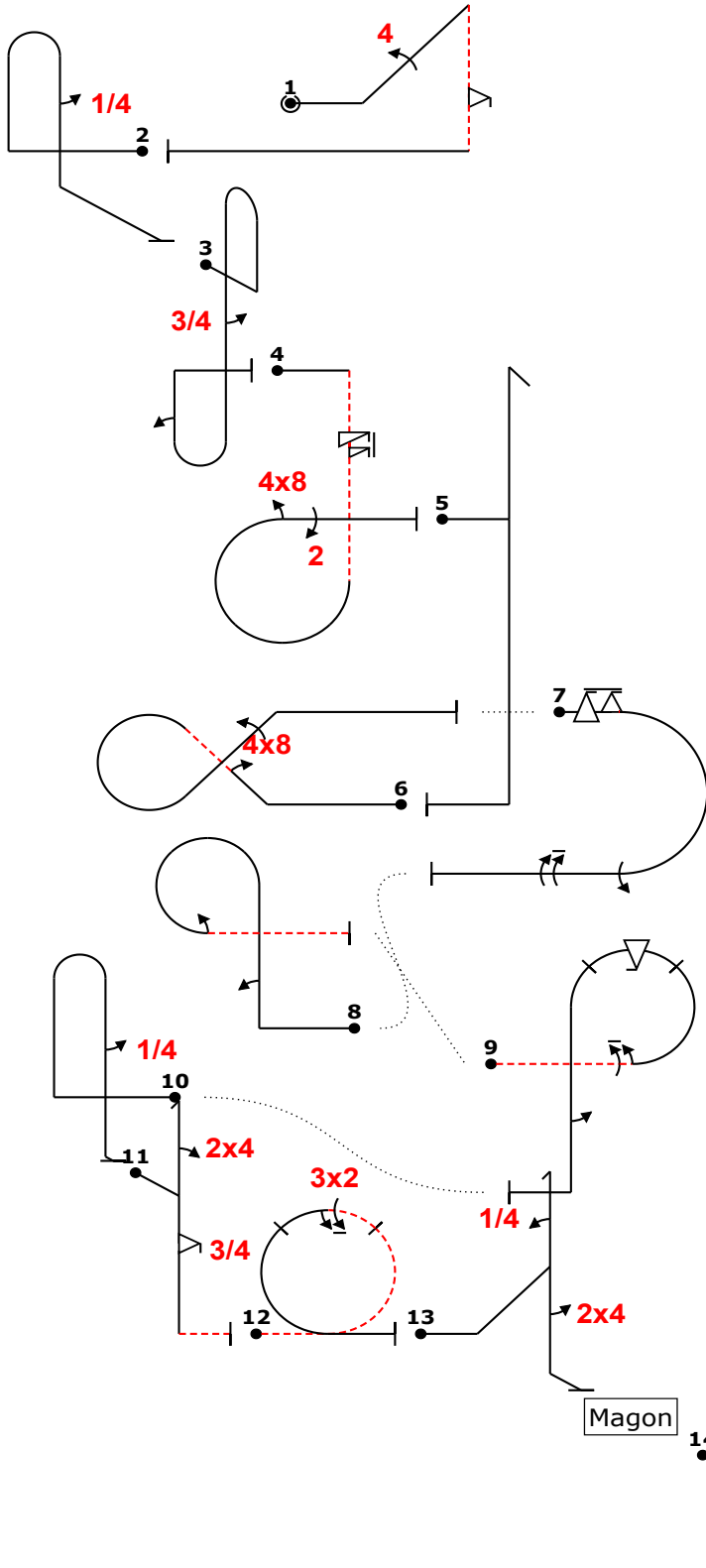
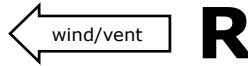

Fig	Grade	Pos	Remarks
1	.		
2	.		
3	.		
4	.		
5	.		
6	.		
7	.		
8	.		
9	.		
10	.		
11	.		
12	.		
13	.		
14	.		

Positioning	
30	.

Too Low		Trg Violation	
Too High		Wing Rocks	
Interruptions		Disqual Fig	
Insertions		Other(note...)	

Fig 1 C	K	Fig 2 L	K	Fig 3 G	K	Fig 4 I	K	Fig 5 L	K	Fig 6 E	K	Fig 7 A	K	Fig 8 L	K	Fig 9 D	K	Fig 10 L	K	Fig 11 B	K	Fig 12 H	K	Fig 13 F	K	Fig 14 J	K
1.2.1.1	13	8.4.1.1	13	8.8.2.1	19	8.6.4.3	13	5.2.1.1	17	7.3.2.1	14	7.2.3.3	6	8.6.2.1	12	8.6.7.2	12	8.4.1.1	13	5.2.1.3	18	7.4.2.2	12	5.3.1.1	18	6.2.2.1	15
9.4.2.4	13	9.1.5.1	2	9.1.5.3	6	9.1.1.6	3			9.8.2.2	9	9.9.3.6	14	9.1.1.2	8	9.1.3.6	10	9.1.5.1	2	9.4.1.2	9	9.2.3.6	12	9.1.1.1	6		
9.9.10.2	13			9.1.1.2	8	9.8.3.2	7			9.1.2.4	10	9.1.3.4	8	9.1.3.2	4	9.9.3.4	11			9.9.5.3	11			9.4.5.2	5		
	39		6		33		32		6		33		40		6		37		6		38		24		29		15

Pilot:

A/C:

Sequence O



CIVA Advanced 10/29/2023
 Programme4 WAAC 2023

Figure K
344
 Total K
374

Judges Name	
Signature	Number

Flight #

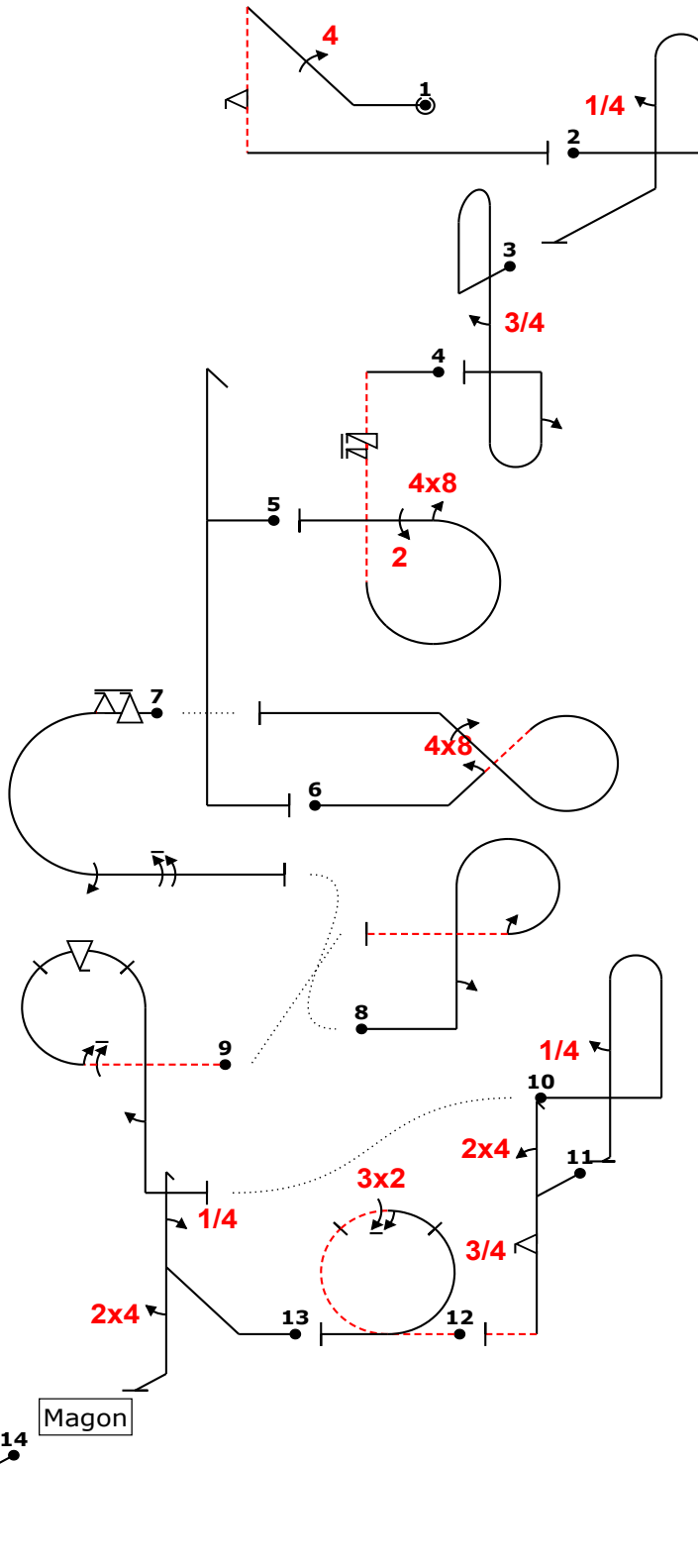
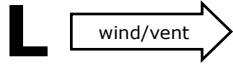

Fig	Grade	Pos	Remarks
1	.		
2	.		
3	.		
4	.		
5	.		
6	.		
7	.		
8	.		
9	.		
10	.		
11	.		
12	.		
13	.		
14	.		

Positioning
30

Too Low		Trg Violation	
Too High		Wing Rocks	
Interruptions		Disqual Fig	
Insertions		Other(note...)	

Fig 1 C	K	Fig 2 L	K	Fig 3 G	K	Fig 4 I	K	Fig 5 L	K	Fig 6 E	K	Fig 7 A	K	Fig 8 L	K	Fig 9 D	K	Fig 10 L	K	Fig 11 B	K	Fig 12 H	K	Fig 13 F	K	Fig 14 J	K
1.2.1.1	13	8.4.1.1	13	8.8.2.1	19	8.6.4.3	13	5.2.1.1	17	7.3.2.1	14	7.2.3.3	6	8.6.2.1	12	8.6.7.2	12	8.4.1.1	13	5.2.1.3	18	7.4.2.2	12	5.3.1.1	18	6.2.2.1	15
9.4.2.4	13	9.1.5.1	2	9.1.5.3	6	9.1.1.6	3			9.8.2.2	9	9.9.3.6	14	9.1.1.2	8	9.1.3.6	10	9.1.5.1	2	9.4.1.2	9	9.2.3.6	12	9.1.1.1	6		
9.9.10.2	13			9.1.1.2	8	9.8.3.2	7			9.1.2.4	10	9.1.3.4	8	9.1.3.2	4	9.9.3.4	11			9.9.5.3	11			9.4.5.2	5		
				9.2.3.4	9							9.1.3.8	12			9.1.5.2	4										
	39		6		33		32		6		33		40		6		37		6		38		24		29		15

Pilot:

A/C:

Sequence P



CIVA Advanced 10/29/2023
 Programme4 WAAC 2023

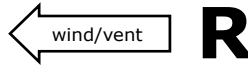

Figure K
344
 Total K
374

Judges Name	
Signature	
Number	

Flight #

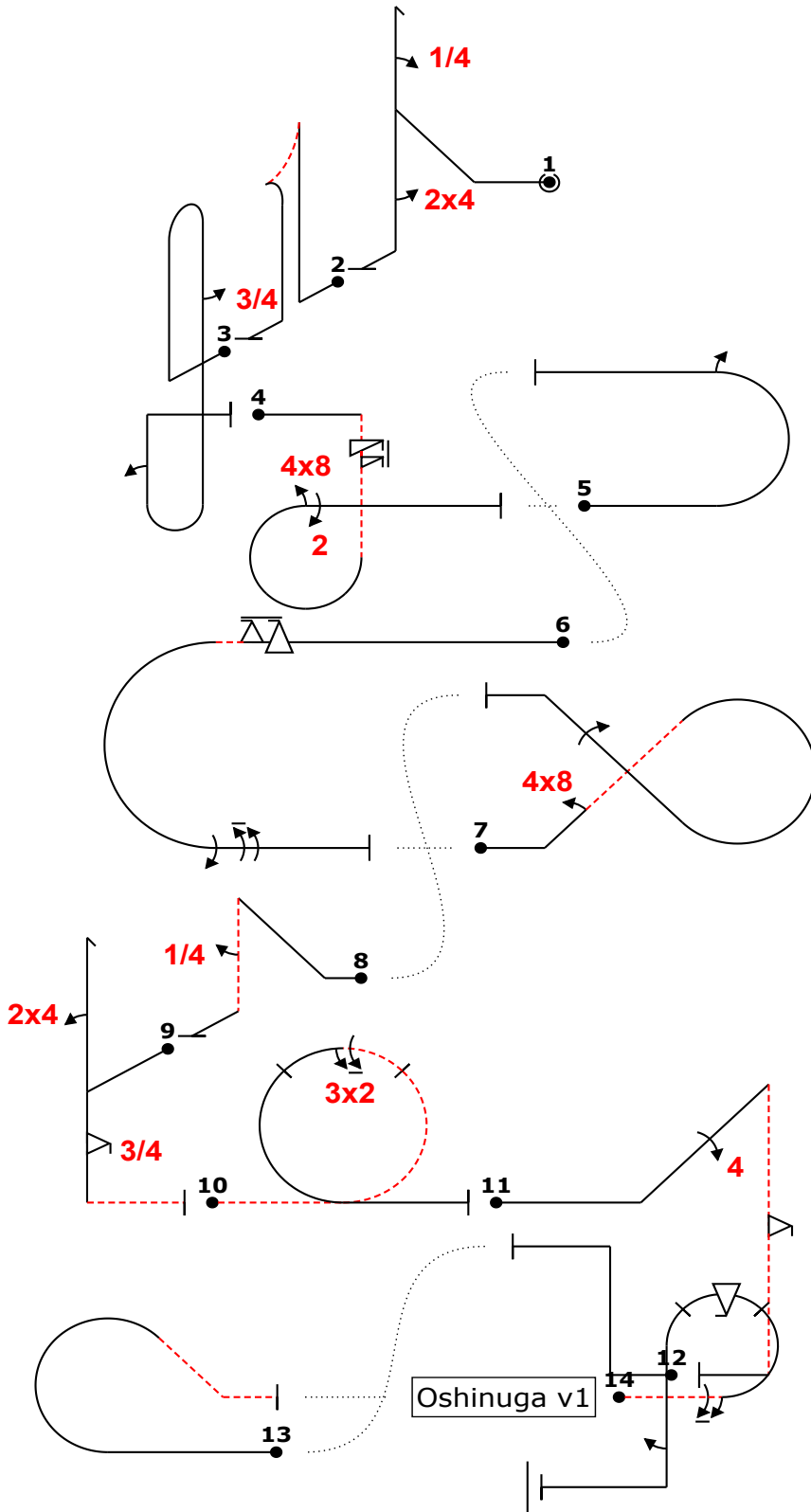

Fig	Grade	Pos	Remarks
1	.		
2	.		
3	.		
4	.		
5	.		
6	.		
7	.		
8	.		
9	.		
10	.		
11	.		
12	.		
13	.		
14	.		

Positioning
30 .

Too Low		Trg Violation	
Too High		Wing Rocks	
Interruptions		Disqual Fig	
Insertions		Other(note...)	

Fig	F	K	Fig	J	K	Fig	G	K	Fig	I	K	Fig	L	K	Fig	A	K	Fig	E	K	Fig	L	K	Fig	B	K	Fig	H	K	Fig	C	K	Fig	L	K	Fig	L	K	Fig	D	K												
5.3.1.1	18	6.2.2.1	15	8.8.2.1	19	8.6.4.3	13	7.2.2.1	6	7.2.3.3	6	7.3.2.1	14	1.2.1.1	13	5.2.1.3	18	7.4.2.2	12	1.2.1.1	13	1.1.6.1	10	8.5.5.1	10	8.6.7.2	12	9.1.1.1	6	9.1.5.3	6	9.1.1.6	3	9.1.3.2	4	9.9.3.6	14	9.8.2.2	9	9.1.5.1	2	9.4.1.2	9	9.2.3.6	12	9.4.2.4	13	9.9.10.2	13	9.9.3.4	11	9.1.5.2	4
9.4.5.2	5			9.1.1.2	8	9.8.3.2	7	9.2.3.4	9	9.1.3.4	8	9.1.2.4	10			9.9.5.3	11																																				
	29		15		33		32		6		40		33		6		38		24		39		6		6																37												

Pilot:

A/C:

Sequence Q



CIVA Advanced 10/29/2023
 Programme4 WAAC 2023

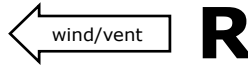

Figure K
344
 Total K
374

Judges Name	
Signature	Number

Flight #

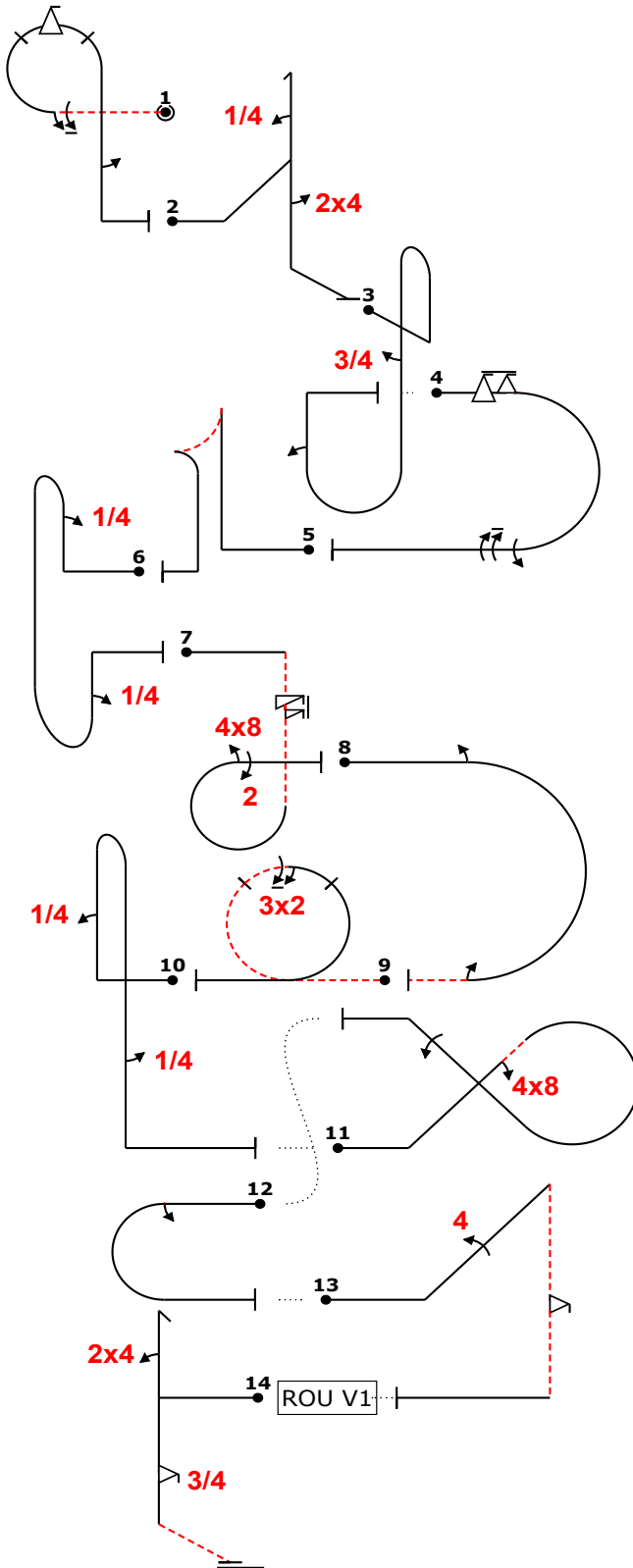

Fig	Grade	Pos	Remarks
1	.		
2	.		
3	.		
4	.		
5	.		
6	.		
7	.		
8	.		
9	.		
10	.		
11	.		
12	.		
13	.		
14	.		

Positioning
30

Too Low		Trg Violation	
Too High		Wing Rocks	
Interruptions		Disqual Fig	
Insertions		Other(note...)	

Fig	D	K	Fig	F	K	Fig	G	K	Fig	A	K	Fig	J	K	Fig	L	K	Fig	I	K	Fig	L	K	Fig	E	K	Fig	L	K	Fig	C	K	Fig	B	K
8.6.7.2	12	5.3.1.1	18	8.8.2.1	19	7.2.3.3	6	6.2.2.1	15	8.8.2.1	19	8.6.4.3	13	7.2.4.3	6	7.4.2.2	12	8.4.1.1	13	7.3.2.1	14	7.2.3.3	6	1.2.1.1	13	5.2.1.3	18								
9.1.3.6	10	9.1.1.1	6	9.1.5.3	6	9.9.3.6	14			9.1.1.1	6	9.1.1.16	3	9.1.3.2	4	9.2.3.6	12	9.1.1.1	6	9.8.2.2	9	9.1.3.2	4	9.4.2.4	13	9.4.1.2	9								
9.9.3.4	11	9.4.5.2	5	9.1.1.2	8	9.1.3.4	8			9.1.1.1	6	9.8.3.2	7	9.1.3.2	4			9.1.5.1	2	9.1.2.4	10			9.9.10.2	13	9.9.5.3	11								
9.1.5.2	4					9.1.3.8	12					9.2.3.4	9																						
	37		29		33		40		15		6		32		6		24		6		33		6		39		38								

Pilot:

A/C:

Sequence Q



CIVA Advanced 10/29/2023
 Programme4 WAAC 2023

Figure K
344
 Total K
374

Judges Name		Flight #
Signature	Number	

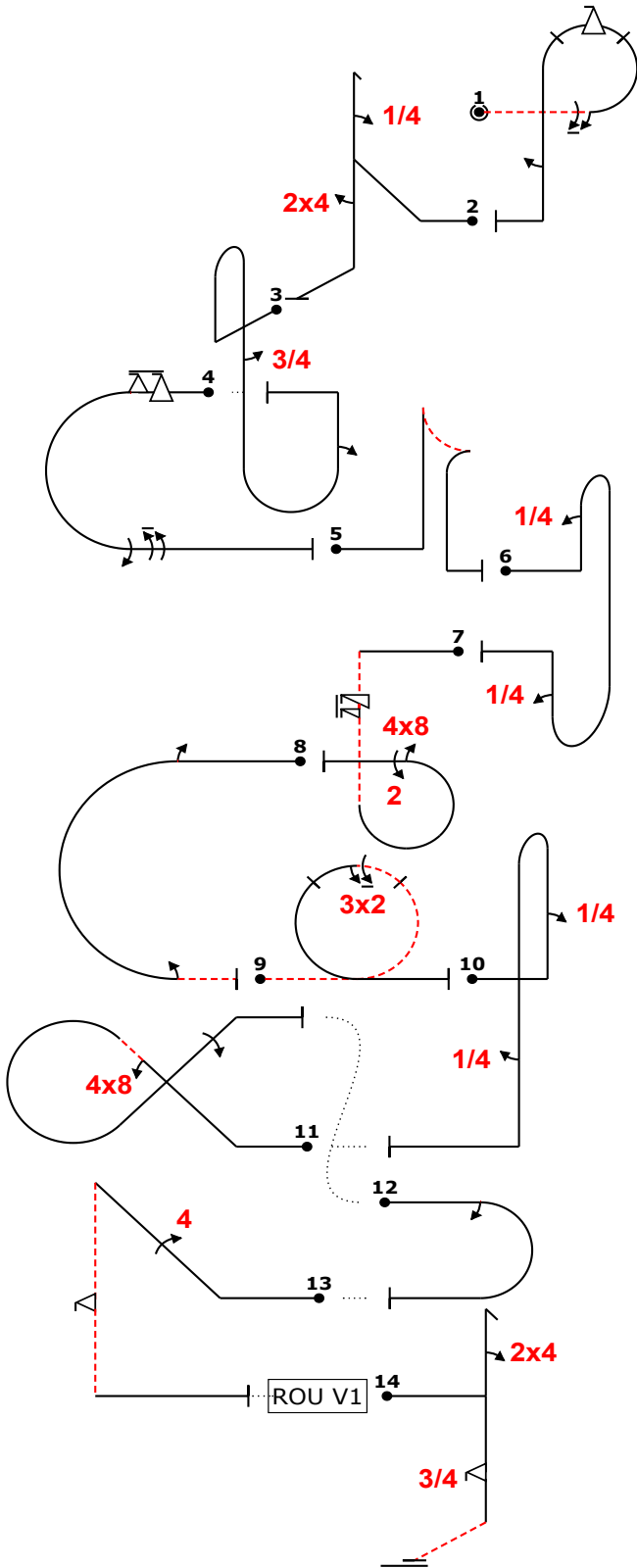
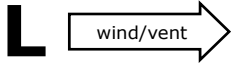

Fig	Grade	Pos	Remarks
1	.		
2	.		
3	.		
4	.		
5	.		
6	.		
7	.		
8	.		
9	.		
10	.		
11	.		
12	.		
13	.		
14	.		

Positioning
30

Too Low		Trg Violation	
Too High		Wing Rocks	
Interruptions		Disqual Fig	
Insertions		Other(note...)	

Fig 1 D	K	Fig 2 F	K	Fig 3 G	K	Fig 4 A	K	Fig 5 J	K	Fig 6 L	K	Fig 7 I	K	Fig 8 L	K	Fig 9 H	K	Fig 10 L	K	Fig 11 E	K	Fig 12 L	K	Fig 13 C	K	Fig 14 B	K
8.6.7.2	12	5.3.1.1	18	8.8.2.1	19	7.2.3.3	6	6.2.2.1	15	8.8.2.1	19	8.6.4.3	13	7.2.4.3	6	7.4.2.2	12	8.4.1.1	13	7.3.2.1	14	7.2.3.3	6	1.2.1.1	13	5.2.1.3	18
9.1.3.6	10	9.1.1.1	6	9.1.5.3	6	9.9.3.6	14			9.1.1.1	6	9.1.1.16	3	9.1.3.2	4	9.2.3.6	12	9.1.1.1	6	9.8.2.2	9	9.1.3.2	4	9.4.2.4	13	9.4.1.2	9
9.9.3.4	11	9.4.5.2	5	9.1.1.2	8	9.1.3.4	8			9.1.1.1	6	9.8.3.2	7	9.1.3.2	4			9.1.5.1	2	9.1.2.4	10			9.9.10.2	13	9.9.5.3	11
9.1.5.2	4					9.1.3.8	12					9.2.3.4	9														
	37		29		33		40		15		6		32		6		24		6		33		6		39		38

Pilot:

A/C:

Sequence R



CIVA Advanced 10/29/2023
 Programme4 WAAC 2023

Figure K
344
 Total K
374

Judges Name		Flight #
Signature	Number	

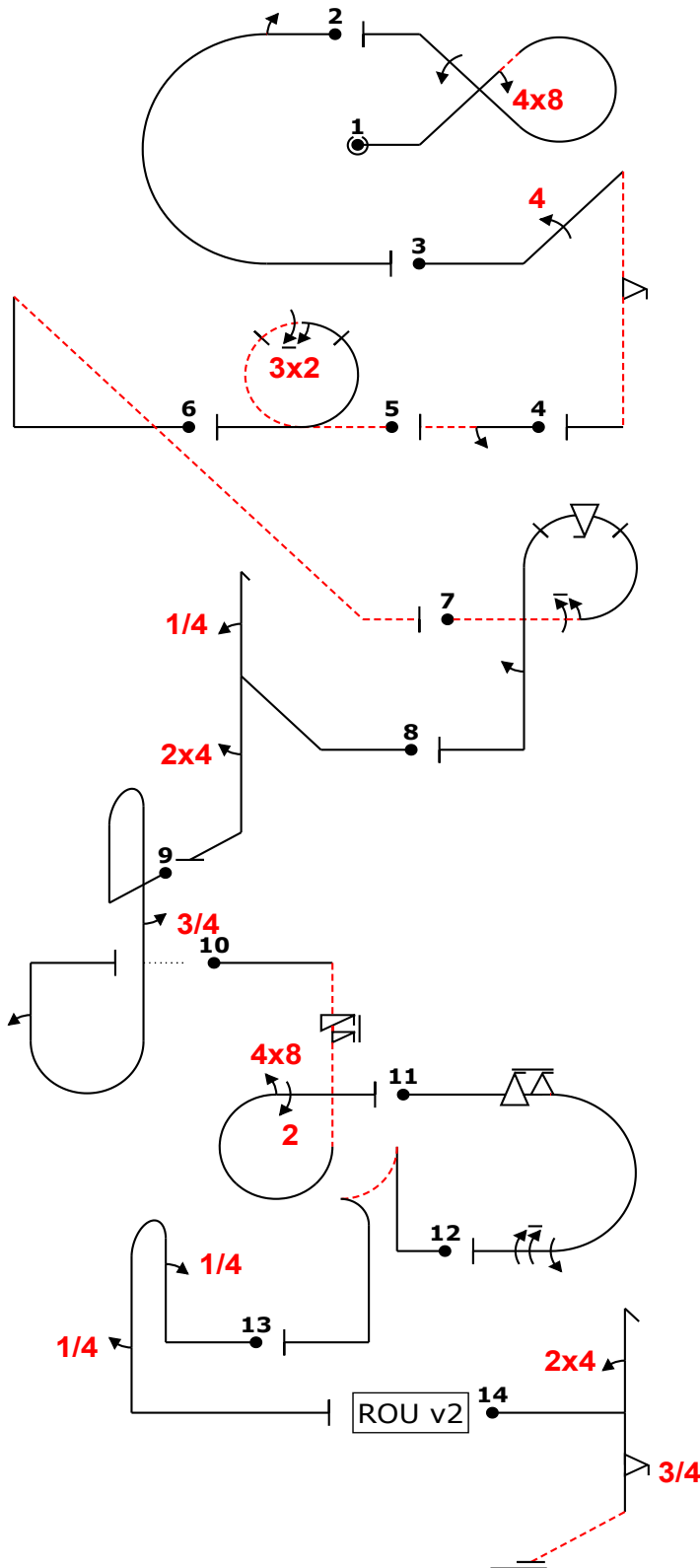
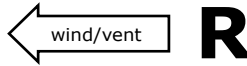

Fig	Grade	Pos	Remarks
1	.		
2	.		
3	.		
4	.		
5	.		
6	.		
7	.		
8	.		
9	.		
10	.		
11	.		
12	.		
13	.		
14	.		

Positioning	
30	.

Too Low		Trg Violation	
Too High		Wing Rocks	
Interruptions		Disqual Fig	
Insertions		Other(note...)	

Fig 1 E	K	Fig 2 L	K	Fig 3 C	K	Fig 4 L	K	Fig 5 H	K	Fig 6 L	K	Fig 7 D	K	Fig 8 F	K	Fig 9 G	K	Fig 10 I	K	Fig 11 A	K	Fig 12 J	K	Fig 13 L	K	Fig 14 B	K
7.3.2.1	14	7.2.3.3	6	1.2.1.1	13	1.1.1.3	2	7.4.2.2	12	1.2.5.1	14	8.6.7.2	12	5.3.1.1	18	8.8.2.1	19	8.6.4.3	13	7.2.3.3	6	6.2.2.1	15	8.4.1.1	13	5.2.1.3	18
9.8.2.2	9	9.1.3.2	4	9.4.2.4	13	9.1.3.2	4	9.2.3.6	12			9.1.3.6	10	9.1.1.1	6	9.1.5.3	6	9.1.1.6	3	9.9.3.6	14			9.1.1.1	6	9.4.1.2	9
9.1.2.4	10			9.9.10.2	13							9.9.3.4	11	9.4.5.2	5	9.1.1.2	8	9.8.3.2	7	9.1.3.4	8			9.1.5.1	2	9.9.5.3	11
	33		6		39		6		24		6		37		29		33		32		40		15		6		38

Pilot:

A/C:

Sequence R



CIVA Advanced 10/29/2023
 Programme4 WAAC 2023

Figure K
344
 Total K
374

Judges Name		Flight #
Signature	Number	

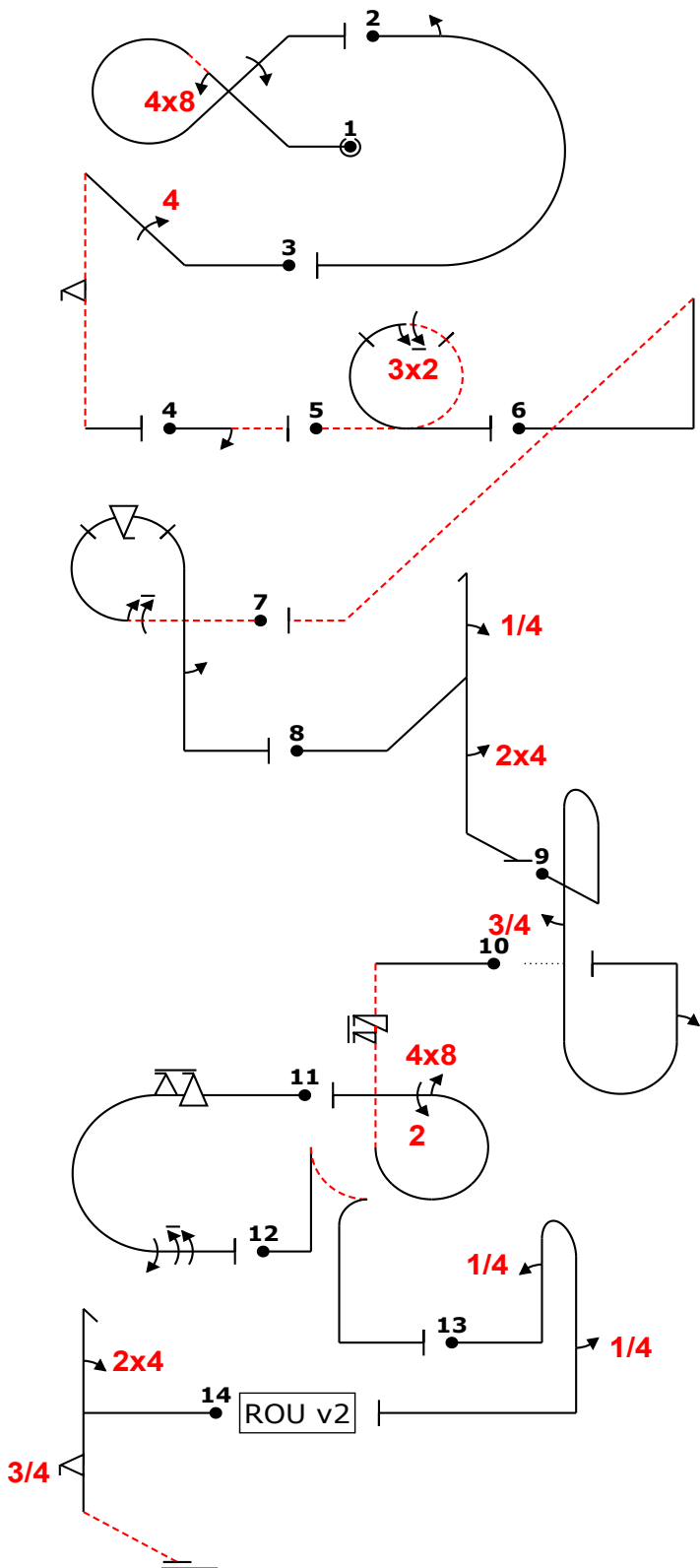
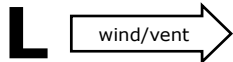

Fig	Grade	Pos	Remarks
1	.		
2	.		
3	.		
4	.		
5	.		
6	.		
7	.		
8	.		
9	.		
10	.		
11	.		
12	.		
13	.		
14	.		

Positioning
30

.

Too Low		Trg Violation	
Too High		Wing Rocks	
Interruptions		Disqual Fig	
Insertions		Other(note...)	

Fig 1 E K	Fig 2 L K	Fig 3 C K	Fig 4 L K	Fig 5 H K	Fig 6 L K	Fig 7 D K	Fig 8 F K	Fig 9 G K	Fig 10 I K	Fig 11 A K	Fig 12 J K	Fig 13 L K	Fig 14 B K
7.3.2.1 14	7.2.3.3 6	1.2.1.1 13	1.1.1.3 2	7.4.2.2 12	1.2.5.1 14	8.6.7.2 12	5.3.1.1 18	8.8.2.1 19	8.6.4.3 13	7.2.3.3 6	6.2.2.1 15	8.4.1.1 13	5.2.1.3 18
9.8.2.2 9	9.1.3.2 4	9.4.2.4 13	9.1.3.2 4	9.2.3.6 12		9.1.3.6 10	9.1.1.1 6	9.1.5.3 6	9.1.1.6 3	9.9.3.6 14		9.1.1.1 6	9.4.1.2 9
9.1.2.4 10		9.9.10.2 13				9.9.3.4 11	9.4.5.2 5	9.1.1.2 8	9.8.3.2 7	9.1.3.4 8		9.1.5.1 2	9.9.5.3 11
						9.1.5.2 4			9.2.3.4 9	9.1.3.8 12			
33	6	39	6	24	6	37	29	33	32	40	15	6	38

Pilot:

A/C:

Sequence S



CIVA Advanced 10/29/2023
Unknown3 WAAC 2023

Figure K
344
Total K
374

Judges Name	
Signature	
Number	

Flight #

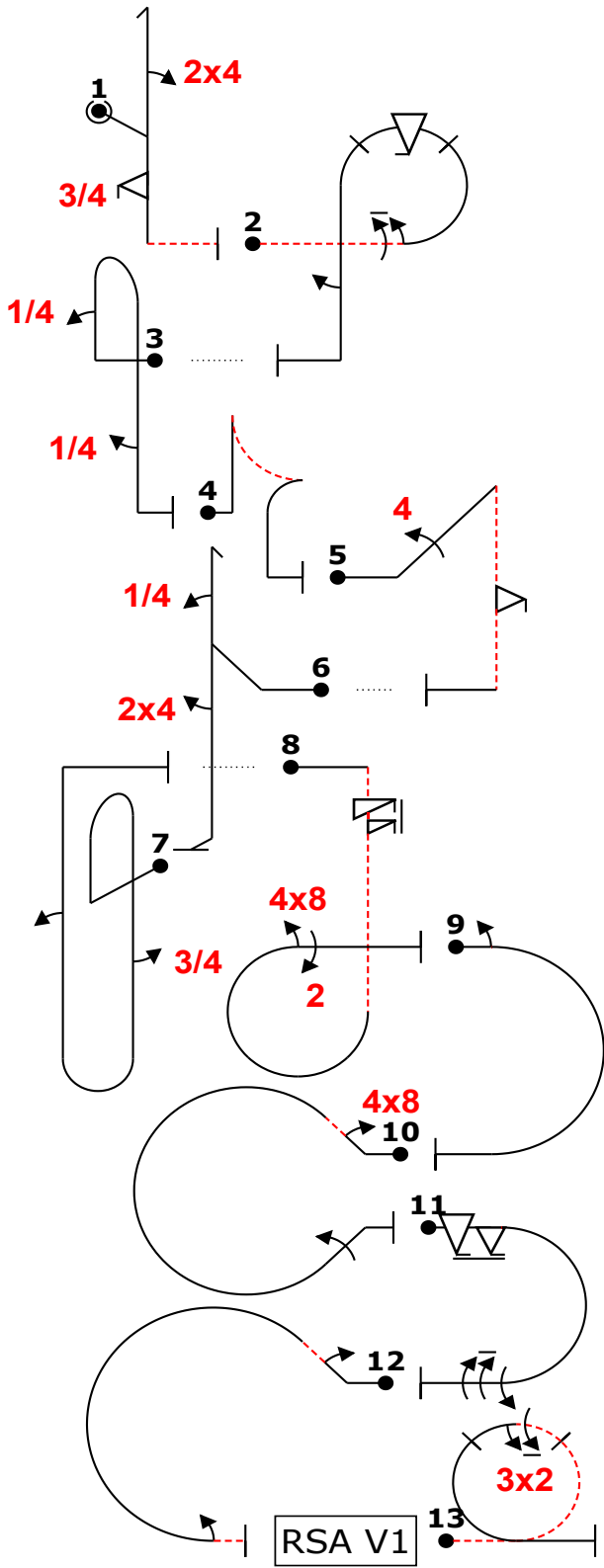
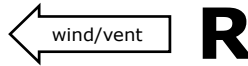

Fig	Grade	Pos	Remarks
1	.		
2	.		
3	.		
4	.		
5	.		
6	.		
7	.		
8	.		
9	.		
10	.		
11	.		
12	.		
13	.		

Positioning
30

Too Low		Trg Violation	
Too High		Wing Rocks	
Interruptions		Disqual Fig	
Insertions		Other(note...)	

Fig 1 B	K	Fig 2 D	K	Fig 3 L	K	Fig 4 J	K	Fig 5 C	K	Fig 6 F	K	Fig 7 G	K	Fig 8 I	K	Fig 9 L	K	Fig 10 E	K	Fig 11 A	K	Fig 12 L	K	Fig 13 H	K
5.2.1.3	18	8.6.7.2	12	8.4.1.1	13	6.2.2.1	15	1.2.1.1	13	5.3.1.1	18	8.8.2.1	19	8.6.4.3	13	7.2.3.3	6	7.3.2.1	14	7.2.3.3	6	8.5.4.1	11	7.4.2.2	12
9.4.1.2	9	9.1.3.6	10	9.1.1.1	6			9.4.2.4	13	9.1.1.1	6	9.1.5.3	6	9.1.1.6	3	9.1.3.2	4	9.8.2.2	9	9.9.3.6	14	9.1.2.2	6	9.2.3.6	12
9.9.5.3	11	9.9.3.4	11	9.1.5.1	2			9.9.10.2	13	9.4.5.2	5	9.1.1.2	8	9.8.3.2	7			9.1.2.4	10	9.1.3.4	8	9.1.3.2	4		
		9.1.5.2	4											9.2.3.4	9					9.1.3.8	12				
	38		37		8		15		39		29		33		32		8		33		40		8		24

Pilot:

A/C:

Team: **RSA**

Sequence S



CIVA Advanced 10/29/2023
Unknown3 WAAC 2023

Figure K
344
Total K
374

Judges Name		Flight #
Signature	Number	

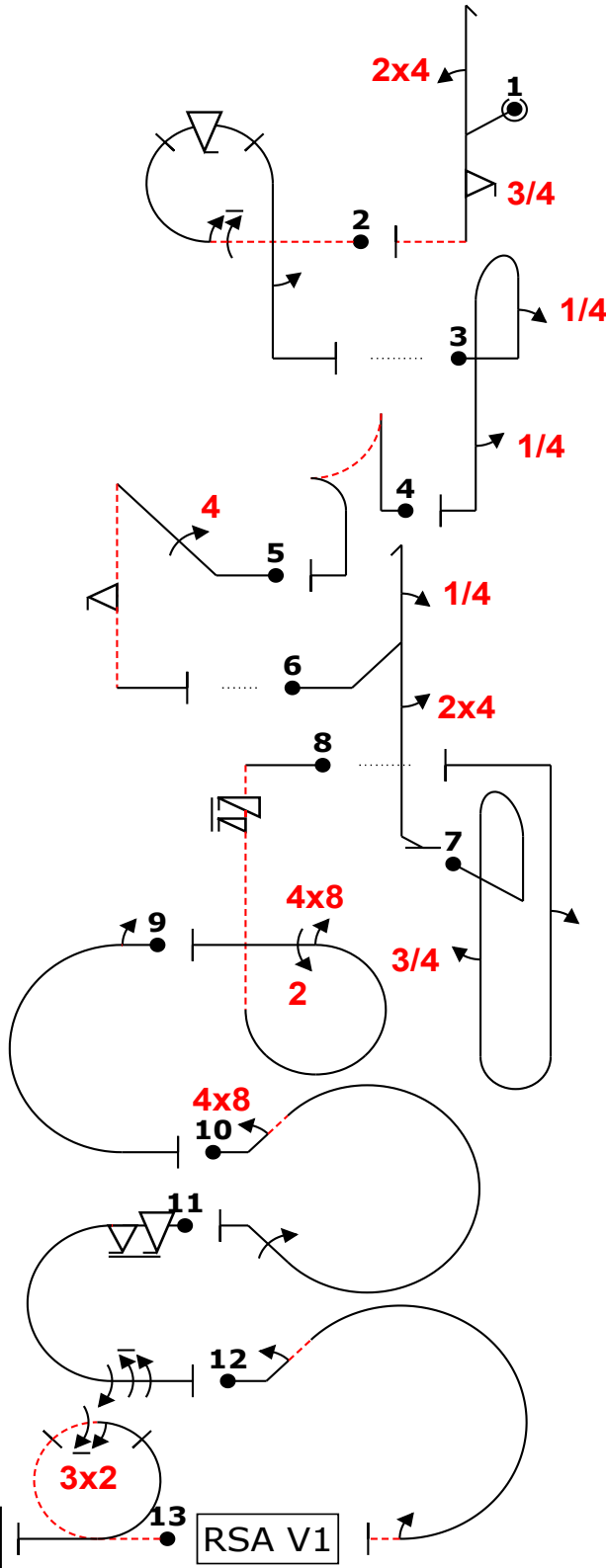
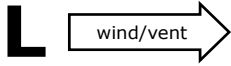

Fig	Grade	Pos	Remarks
1	.		
2	.		
3	.		
4	.		
5	.		
6	.		
7	.		
8	.		
9	.		
10	.		
11	.		
12	.		
13	.		

Positioning
30

Too Low		Trg Violation	
Too High		Wing Rocks	
Interruptions		Disqual Fig	
Insertions		Other(note...)	

Fig 1 B	K	Fig 2 D	K	Fig 3 L	K	Fig 4 J	K	Fig 5 C	K	Fig 6 F	K	Fig 7 G	K	Fig 8 I	K	Fig 9 L	K	Fig 10 E	K	Fig 11 A	K	Fig 12 L	K	Fig 13 H	K
5.2.1.3	18	8.6.7.2	12	8.4.1.1	13	6.2.2.1	15	1.2.1.1	13	5.3.1.1	18	8.8.2.1	19	8.6.4.3	13	7.2.3.3	6	7.3.2.1	14	7.2.3.3	6	8.5.4.1	11	7.4.2.2	12
9.4.1.2	9	9.1.3.6	10	9.1.1.1	6			9.4.2.4	13	9.1.1.1	6	9.1.5.3	6	9.1.1.6	3	9.1.3.2	4	9.8.2.2	9	9.9.3.6	14	9.1.2.2	6	9.2.3.6	12
9.9.5.3	11	9.9.3.4	11	9.1.5.1	2			9.9.10.2	13	9.4.5.2	5	9.1.1.2	8	9.8.3.2	7			9.1.2.4	10	9.1.3.4	8	9.1.3.2	4		
		9.1.5.2	4											9.2.3.4	9					9.1.3.8	12				
	38		37		8		15		39		29		33		32		8		33		40		8		24

Pilot:

A/C:

Team: **RSA**

Sequence T



CIVA Advanced 10/29/2023
 Programme4 WAAC 2023



Figure K
344
 Total K
374

Judges Name	
Signature	
Number	

Flight #

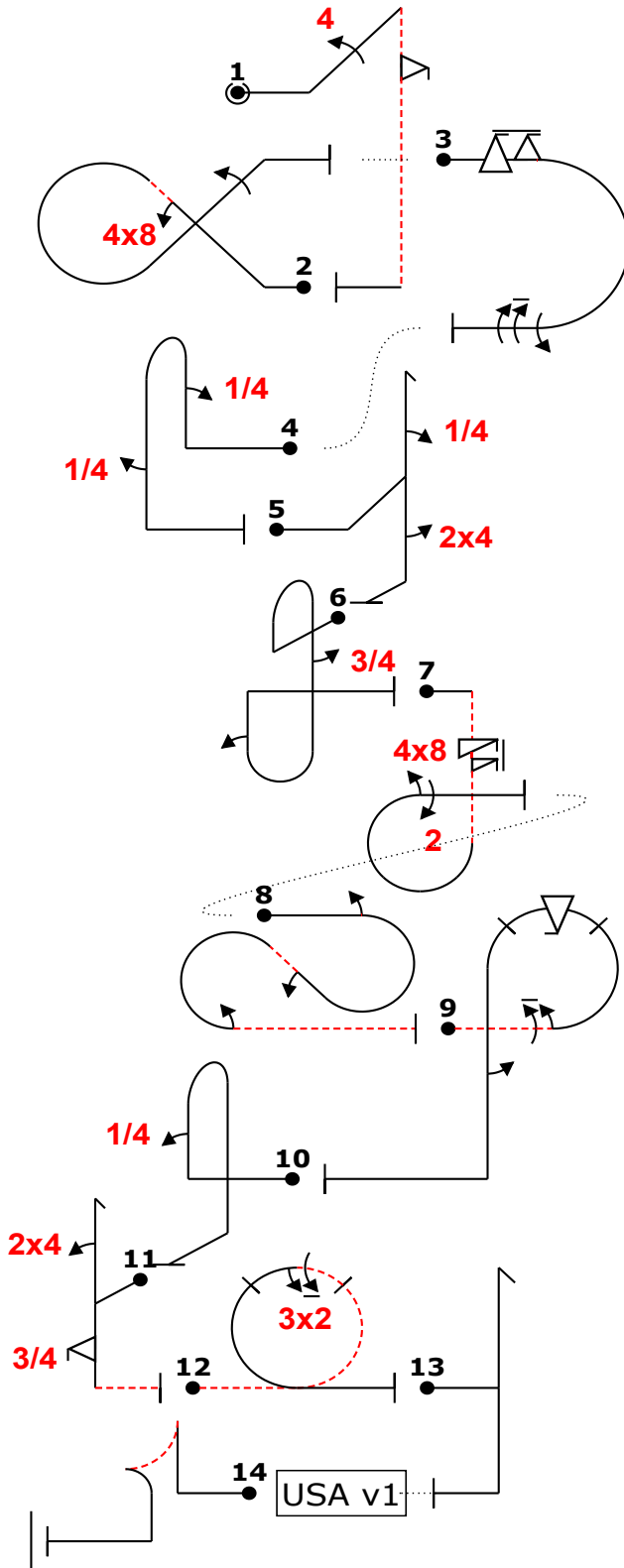

Fig	Grade	Pos	Remarks
1	.		
2	.		
3	.		
4	.		
5	.		
6	.		
7	.		
8	.		
9	.		
10	.		
11	.		
12	.		
13	.		
14	.		

Positioning
30

Too Low		Trg Violation	
Too High		Wing Rocks	
Interruptions		Disqual Fig	
Insertions		Other(note...)	

Fig 1 C	K	Fig 2 E	K	Fig 3 A	K	Fig 4 L	K	Fig 5 F	K	Fig 6 G	K	Fig 7 I	K	Fig 8 L	K	Fig 9 D	K	Fig 10 L	K	Fig 11 B	K	Fig 12 H	K	Fig 13 L	K	Fig 14 J	K
1.2.1.1	13	7.3.2.1	14	7.2.3.3	6	8.4.1.1	13	5.3.1.1	18	8.8.2.1	19	8.6.4.3	13	7.5.8.3	15	8.6.7.2	12	8.4.1.1	13	5.2.1.3	18	7.4.2.2	12	5.2.1.1	17	6.2.2.1	15
9.4.2.4	13	9.8.2.2	9	9.9.3.6	14	9.1.1.1	6	9.1.1.1	6	9.1.5.3	6	9.1.1.6	3	9.1.3.2	4	9.1.3.6	10	9.1.1.1	6	9.4.1.2	9	9.2.3.6	12				
9.9.10.2	13	9.1.2.4	10	9.1.3.4	8	9.1.5.1	2	9.4.5.2	5	9.1.1.2	8	9.8.3.2	7	9.1.2.2	6	9.9.3.4	11			9.9.5.3	11						
				9.1.3.8	12							9.2.3.4	9	9.1.3.2	4	9.1.5.2	4										
	39		33		40		6		29		33		32		6		37		6		38		24		6		

Pilot:

A/C:

Sequence T



CIVA Advanced 10/29/2023
 Programme4 WAAC 2023

Figure K
344
 Total K
374

Judges Name	
Signature	Number

Flight #

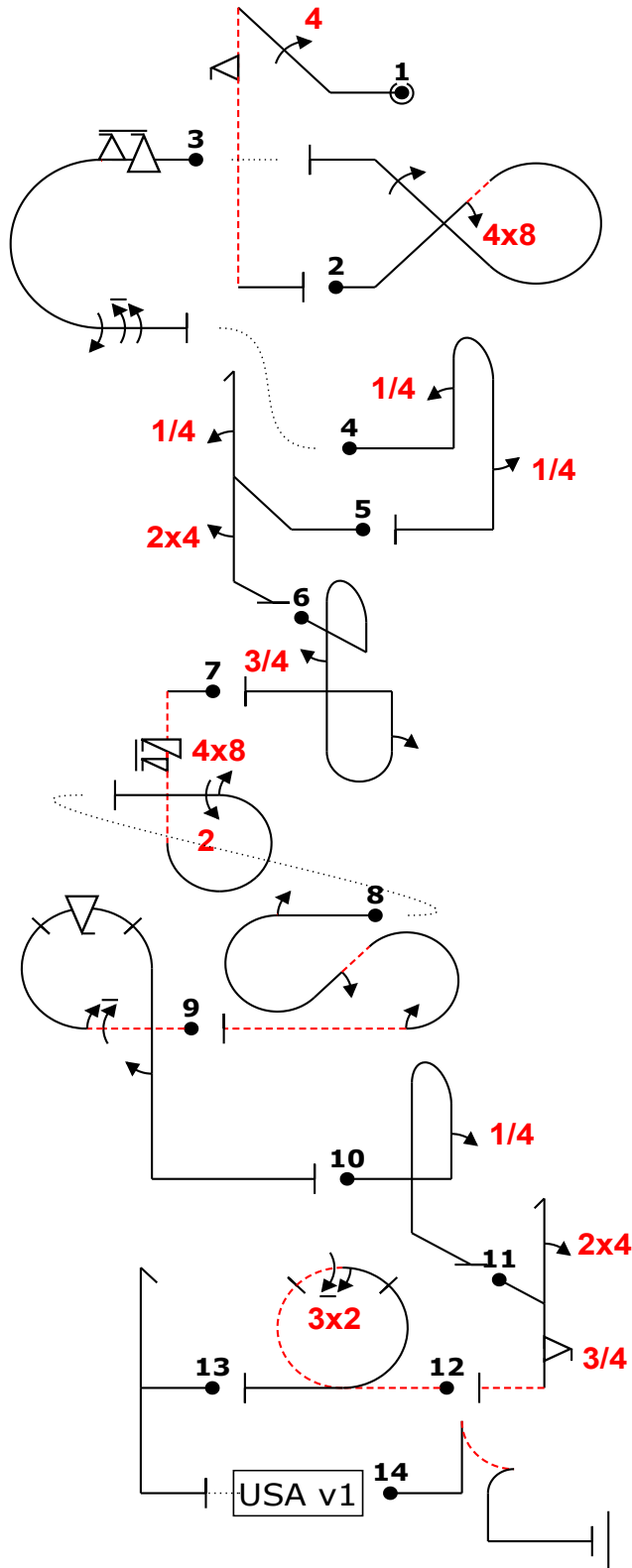
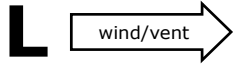

Fig	Grade	Pos	Remarks
1	.		
2	.		
3	.		
4	.		
5	.		
6	.		
7	.		
8	.		
9	.		
10	.		
11	.		
12	.		
13	.		
14	.		

Positioning
30 .

Too Low		Trg Violation	
Too High		Wing Rocks	
Interruptions		Disqual Fig	
Insertions		Other(note...)	

Fig 1 C	K	Fig 2 E	K	Fig 3 A	K	Fig 4 L	K	Fig 5 F	K	Fig 6 G	K	Fig 7 I	K	Fig 8 L	K	Fig 9 D	K	Fig 10 L	K	Fig 11 B	K	Fig 12 H	K	Fig 13 L	K	Fig 14 J	K
1.2.1.1	13	7.3.2.1	14	7.2.3.3	6	8.4.1.1	13	5.3.1.1	18	8.8.2.1	19	8.6.4.3	13	7.5.8.3	15	8.6.7.2	12	8.4.1.1	13	5.2.1.3	18	7.4.2.2	12	5.2.1.1	17	6.2.2.1	15
9.4.2.4	13	9.8.2.2	9	9.9.3.6	14	9.1.1.1	6	9.1.1.1	6	9.1.5.3	6	9.1.1.6	3	9.1.3.2	4	9.1.3.6	10	9.1.1.1	6	9.4.1.2	9	9.2.3.6	12				
9.9.10.2	13	9.1.2.4	10	9.1.3.4	8	9.1.5.1	2	9.4.5.2	5	9.1.1.2	8	9.8.3.2	7	9.1.2.2	6	9.9.3.4	11			9.9.5.3	11						
				9.1.3.8	12							9.2.3.4	9	9.1.3.2	4	9.1.5.2	4										
	39		33		40		6		29		33		32		6		37		6		38		24		6		15

Pilot:

A/C:

Sequence U



CIVA	Advanced
Programme4	

Figure K
344
Total K
374

Judges Name	
Signature	Number

Flight #

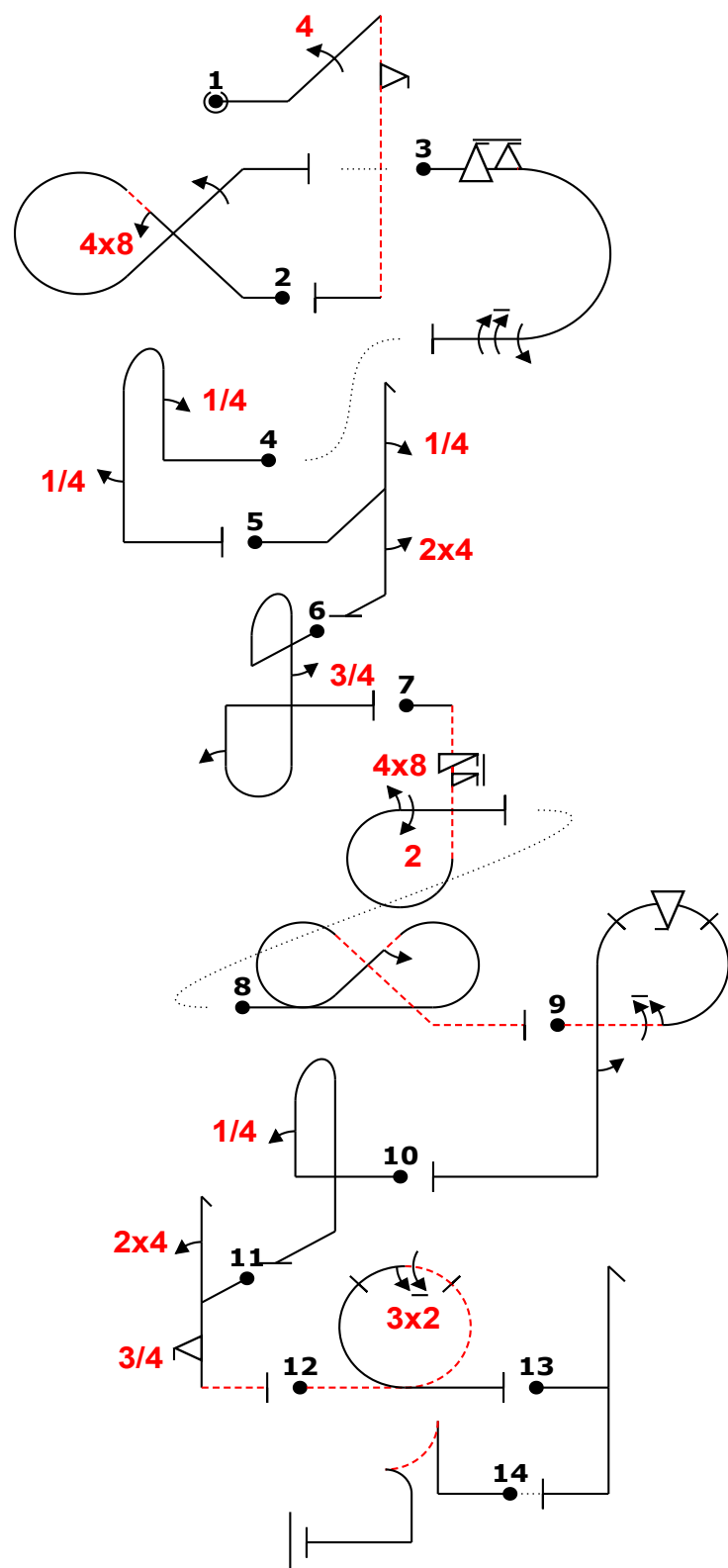
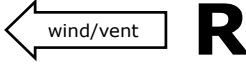

Fig	Grade	Pos	Remarks
1	.		
2	.		
3	.		
4	.		
5	.		
6	.		
7	.		
8	.		
9	.		
10	.		
11	.		
12	.		
13	.		
14	.		

Positioning	
30	.

Too Low		Trg Violation	
Too High		Wing Rocks	
Interruptions		Disqual Fig	
Insertions		Other(note...)	

Fig 1 C	K	Fig 2 E	K	Fig 3 A	K	Fig 4 L	K	Fig 5 F	K	Fig 6 G	K	Fig 7 I	K	Fig 8 L	K	Fig 9 D	K	Fig 10 L	K	Fig 11 B	K	Fig 12 H	K	Fig 13 L	K	Fig 14 J	K
1.2.1.1	13	7.3.2.1	14	7.2.3.3	6	8.4.1.1	13	5.3.1.1	18	8.8.2.1	19	8.6.4.3	13	7.8.3.1	19	8.6.7.2	12	8.4.1.1	13	5.2.1.3	18	7.4.2.2	12	5.2.1.1	17	6.2.2.1	15
9.4.2.4	13	9.8.2.2	9	9.9.3.6	14	9.1.1.1	6	9.1.1.1	6	9.1.5.3	6	9.1.1.16	3	9.1.4.2	4	9.1.3.6	10	9.1.1.1	6	9.4.1.2	9	9.2.3.6	12				
9.9.10.2	13	9.1.2.4	10	9.1.3.4	8	9.1.5.1	2	9.4.5.2	5	9.1.1.2	8	9.8.3.2	7			9.9.3.4	11			9.9.5.3	11						
				9.1.3.8	12							9.2.3.4	9			9.1.5.2	4										
	39		33		40		6		29		33		32		6		37		6		38		24		6		15

Pilot:

A/C:

Sequence V



CIVA Advanced 10/29/2023
 Programme4 WAAC 2023

Figure K
344
 Total K
374

Judges Name	
Signature	Number

Flight #

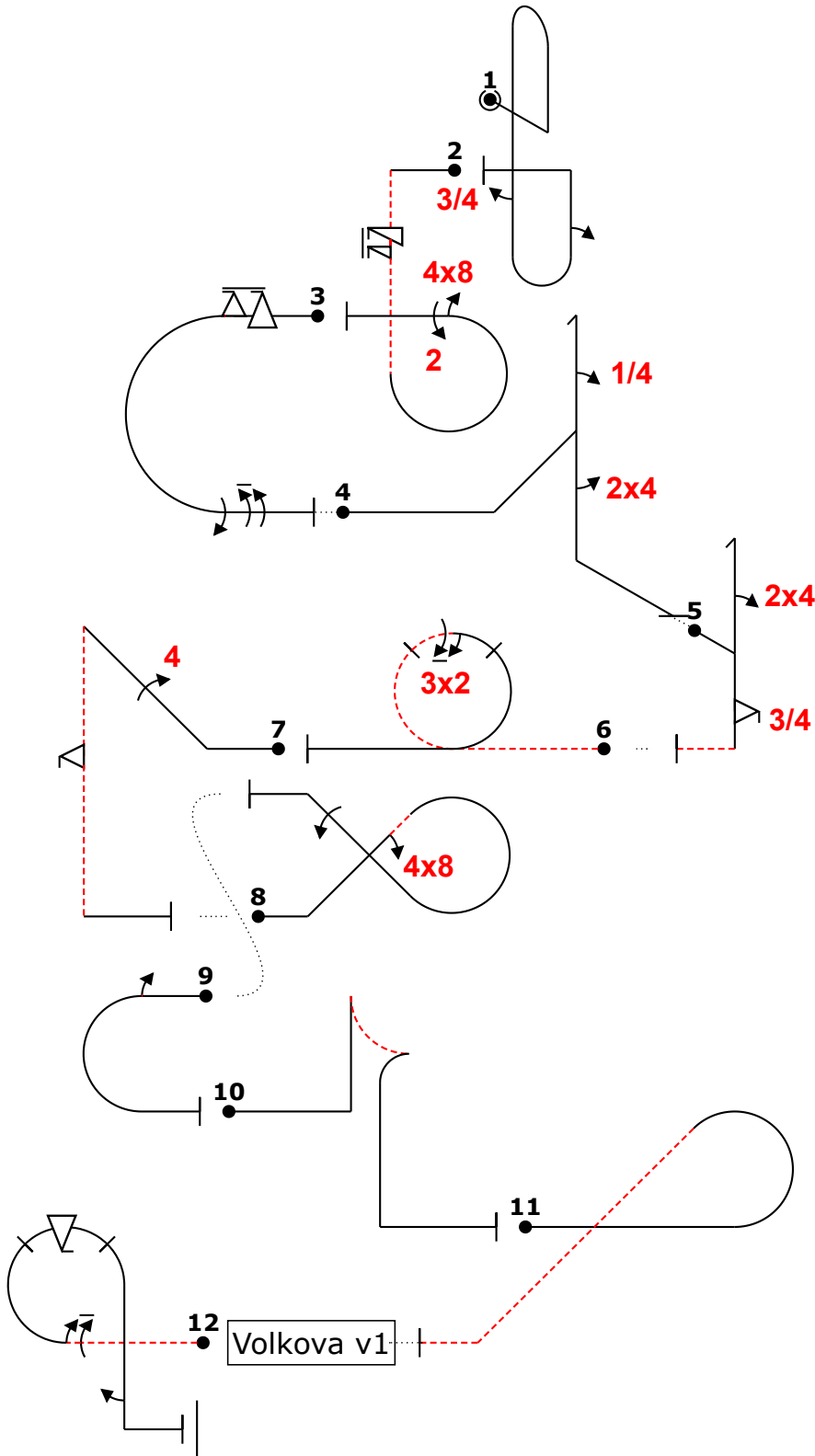
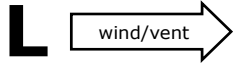

Fig	Grade	Pos	Remarks
1	.		
2	.		
3	.		
4	.		
5	.		
6	.		
7	.		
8	.		
9	.		
10	.		
11	.		
12	.		

Positioning
30 .

Too Low		Trg Violation	
Too High		Wing Rocks	
Interruptions		Disqual Fig	
Insertions		Other(note...)	

Fig 1 G	K	Fig 2 I	K	Fig 3 A	K	Fig 4 F	K	Fig 5 B	K	Fig 6 H	K	Fig 7 C	K	Fig 8 E	K	Fig 9 L	K	Fig 10 J	K	Fig 11 L	K	Fig 12 D	K
8.8.2.1	19	8.6.4.3	13	7.2.3.3	6	5.3.1.1	18	5.2.1.3	18	7.4.2.2	12	1.2.1.1	13	7.3.2.1	14	7.2.3.3	6	6.2.2.1	15	8.5.5.1	10	8.6.7.2	12
9.1.5.3	6	9.11.1.6	3	9.9.3.6	14	9.1.1.1	6	9.4.1.2	9	9.2.3.6	12	9.4.2.4	13	9.8.2.2	9	9.1.3.2	4					9.1.3.6	10
9.1.1.2	8	9.8.3.2	7	9.1.3.4	8	9.4.5.2	5	9.9.5.3	11			9.9.10.2	13	9.1.2.4	10							9.9.3.4	11
		9.2.3.4	9	9.1.3.8	12																	9.1.5.2	4
	33		32		40		29		38		24		39		33		12		15		12		37

Pilot:

A/C:

Sequence W



CIVA Advanced 10-29-23
 Programme4 WAAC 2023



Figure K
344
 Total K
374

Judges Name		Flight #
Signature	Number	

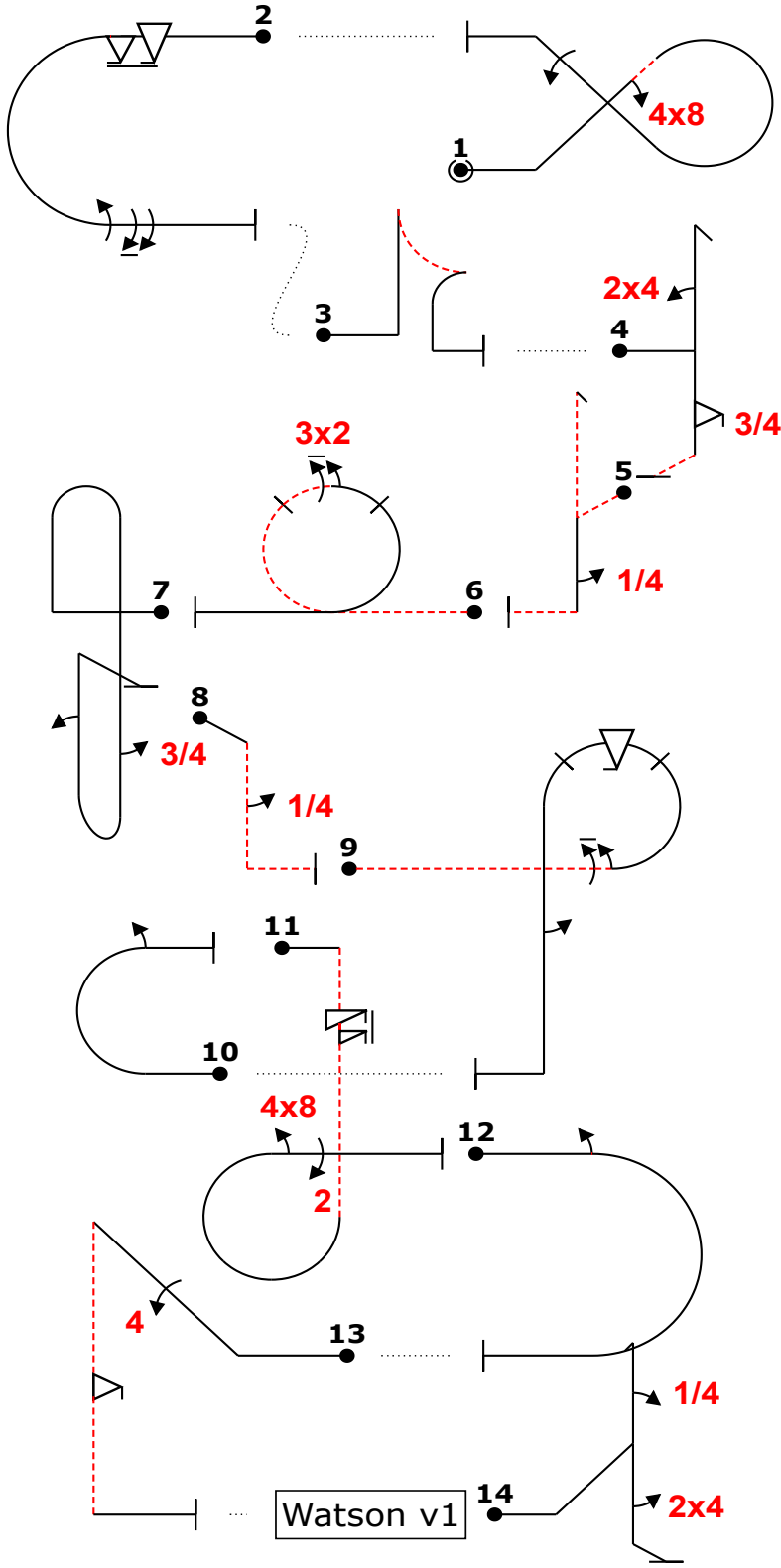

Fig	Grade	Pos	Remarks
1	.		
2	.		
3	.		
4	.		
5	.		
6	.		
7	.		
8	.		
9	.		
10	.		
11	.		
12	.		
13	.		
14	.		

Positioning
30

Too Low		Trg Violation	
Too High		Wing Rocks	
Interruptions		Disqual Fig	
Insertions		Other(note...)	

Fig 1 E	K	Fig 2 A	K	Fig 3 J	K	Fig 4 B	K	Fig 5 L	K	Fig 6 H	K	Fig 7 G	K	Fig 8 L	K	Fig 9 D	K	Fig 10 L	K	Fig 11 I	K	Fig 12 L	K	Fig 13 C	K	Fig 14 F	K
7.3.2.1	14	7.2.3.3	6	6.2.2.1	15	5.2.1.3	18	5.2.1.2	23	7.4.2.2	12	8.8.2.1	19	1.1.7.3	11	8.6.7.2	12	7.2.2.1	6	8.6.4.3	13	7.2.3.3	6	1.2.1.1	13	5.3.1.1	18
9.8.2.2	9	9.9.3.6	14			9.4.1.2	9	9.1.5.1	2	9.2.3.6	12	9.1.5.3	6	9.1.5.1	2	9.1.3.6	10	9.1.3.2	4	9.1.1.6	3	9.1.3.2	4	9.4.2.4	13	9.1.1.1	6
9.1.2.4	10	9.1.3.4	8			9.9.5.3	11					9.1.1.2	8			9.9.3.4	11			9.8.3.2	7			9.9.10.2	13	9.4.5.2	5
		9.1.3.8	12									9.1.5.2	4			9.1.5.2	4			9.2.3.4	9						
	33		40		15		38		6		24		33		6		37		6		32		6		39		29

Pilot: **watson**

A/C: **mx2 451ee**

Team: **IND**

Sequence W



CIVA Advanced 10-29-23
 Programme4 WAAC 2023

Figure K
344
 Total K
374

Judges Name		Flight #
Signature	Number	

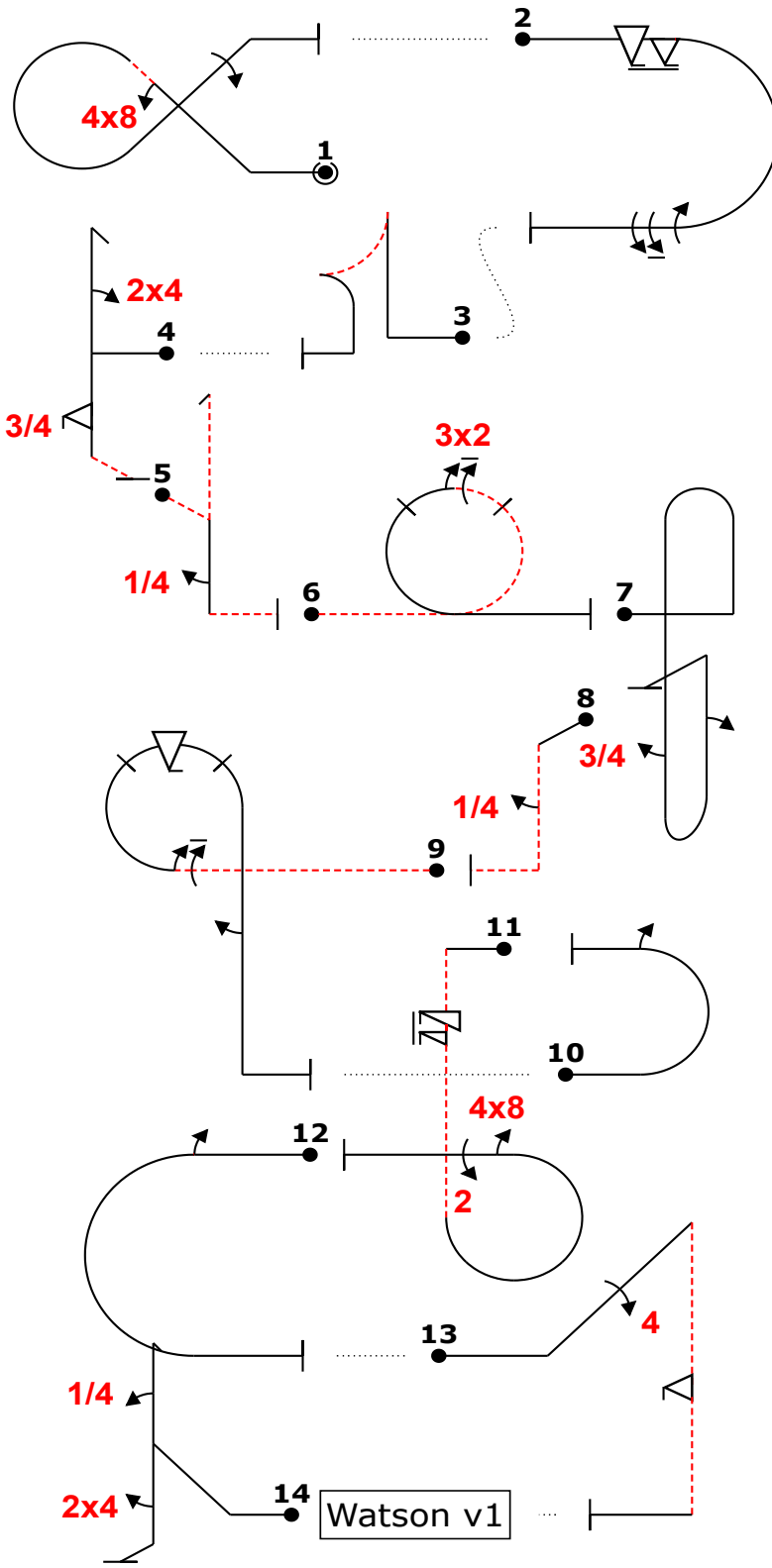
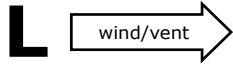

Fig	Grade	Pos	Remarks
1	.		
2	.		
3	.		
4	.		
5	.		
6	.		
7	.		
8	.		
9	.		
10	.		
11	.		
12	.		
13	.		
14	.		

Positioning
30

Too Low		Trg Violation	
Too High		Wing Rocks	
Interruptions		Disqual Fig	
Insertions		Other(note...)	

Fig 1 E	K	Fig 2 A	K	Fig 3 J	K	Fig 4 B	K	Fig 5 L	K	Fig 6 H	K	Fig 7 G	K	Fig 8 L	K	Fig 9 D	K	Fig 10 L	K	Fig 11 I	K	Fig 12 L	K	Fig 13 C	K	Fig 14 F	K
7.3.2.1	14	7.2.3.3	6	6.2.2.1	15	5.2.1.3	18	5.2.1.2	23	7.4.2.2	12	8.8.2.1	19	1.1.7.3	11	8.6.7.2	12	7.2.2.1	6	8.6.4.3	13	7.2.3.3	6	1.2.1.1	13	5.3.1.1	18
9.8.2.2	9	9.9.3.6	14			9.4.1.2	9	9.1.5.1	2	9.2.3.6	12	9.1.5.3	6	9.1.5.1	2	9.1.3.6	10	9.1.3.2	4	9.1.1.6	3	9.1.3.2	4	9.4.2.4	13	9.1.1.1	6
9.1.2.4	10	9.1.3.4	8			9.9.5.3	11					9.1.1.2	8			9.9.3.4	11			9.8.3.2	7			9.9.10.2	13	9.4.5.2	5
		9.1.3.8	12													9.1.5.2	4			9.2.3.4	9						
	33		40		15		38		6		24		33		6		37		6		32		6		39		29

Pilot: **watson**

A/C: **mx2 451ee**

Team: **IND**